

Winter 1997

Micro-Cap V Version 2.0

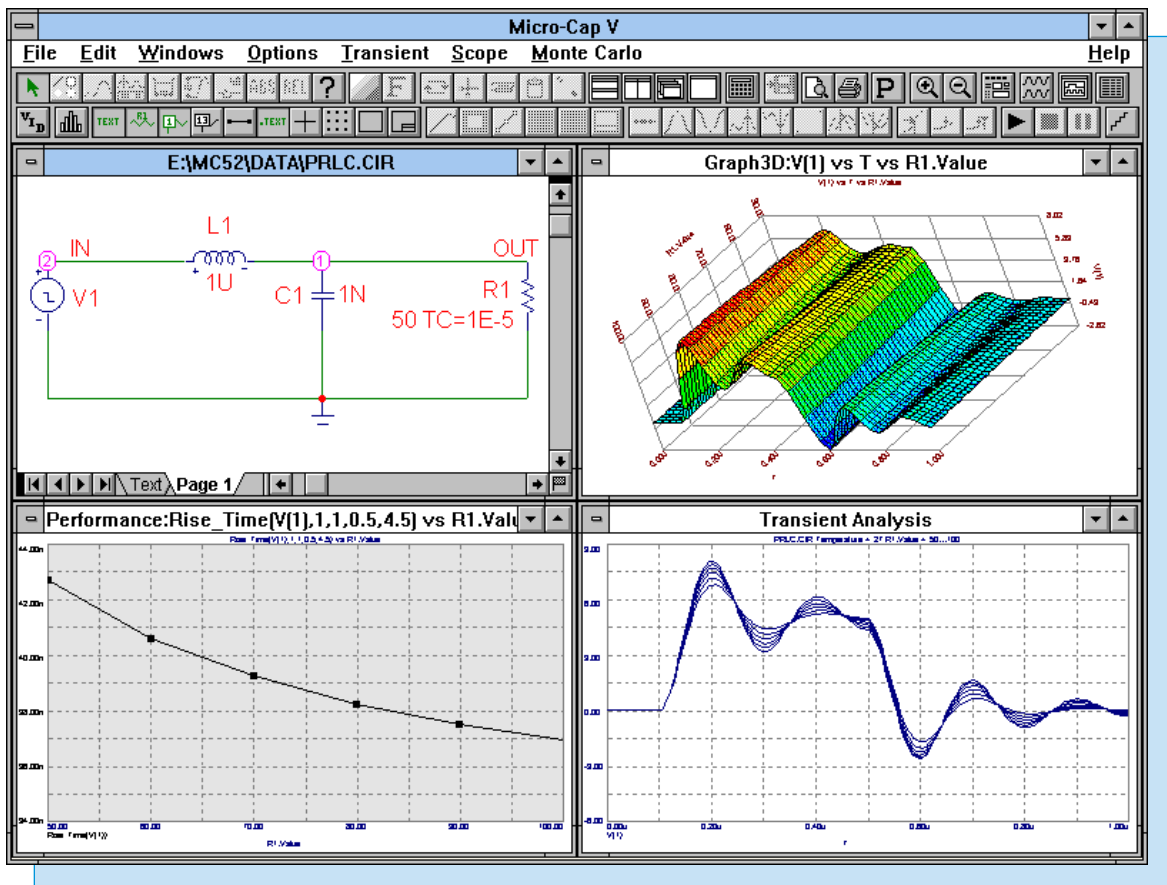

Featuring:

- Introducing Micro-Cap V Version 2.0
- Sample and Hold Macro
- Gyrator Macro
- The Dangers of Aliasing

News In Preview

This issue of the Spectrum News provides the first introduction to the next version of Micro-Cap, Micro-Cap V Version 2.0. This article will describe the main improvements and features that have been added into our newest version. This issue also presents two new macros - the sample and hold macro and the gyrator macro. These articles describe the workings of the macros and then runs each of them through a test. Finally, there is an article describing the dangers of aliasing, how to spot it, and what to do about it.

Contents

News In Preview	2
Book Recommendations	3
Updates Now Available on Web Page	3
Micro-Cap V Question and Answer	4
Introducing Micro-Cap V Version 2.....	5
Sample and Hold Macro	13
Gyrator Macro	15
The Dangers of Aliasing	17
Product Sheet	21

Book Recommendations

- *Electronic Devices and Circuits Using MICRO-CAP II*, Richard H. Berube, Merril 1992. ISBN# 0-02-309160-6
- *Electronic Devices and Circuits Using MICRO-CAP III*, Richard H. Berube, Merril 1993. ISBN# 0-02-309151-7
- *Computer-Aided Circuit Analysis Using SPICE*, Walter Banzhaf, Prentice Hall 1989. ISBN# 0-13-162579-9
- *Macromodeling with SPICE*, Connelly and Choi, Prentice Hall 1992. ISBN# 0-13-544941-3
- *Semiconductor Device Modeling with SPICE*, Paolo Antognetti and Giuseppe Massobrio McGraw-Hill, Second Edition, 1993. ISBN# 0-07-002107-4
- *Inside SPICE-Overcoming the Obstacles of Circuit Simulation*, Ron Kielkowski, McGraw-Hill, First Edition, 1993. ISBN# 0-07-911525-X
- *The SPICE Book*, Andrei Vladimirescu, John Wiley & Sons, Inc., First Edition, 1994. ISBN# 0-471-60926-9
- *SMPS Simulation with SPICE 3*, Steven M. Sandler, McGraw Hill, First Edition, 1997. ISBN# 0-07-913227-8

German

- *Schaltungen erfolgreich simulieren mit Micro-Cap V*, Walter Gunther, Franzis', First Edition, 1997. ISBN# 3-7723-4662-6

Updates Now Available on Web Page

The latest professional version of the Micro-Cap V Version 1 executable file is now available for downloading from our web page at:

<http://www.spectrum-soft.com/update.html>

This executable will only work if the appropriate hardware key is available.

Micro-Cap V Question and Answer

Caller1: I placed one of the vendor supplied subcircuits in my schematic, and I want to see the SPICE listing for this subcircuit. How do I do this?

Tech: You need to get into Info mode. Go to the Options menu and click on Mode and then Info. All you need to do now is to click on the subcircuit in the schematic. The library that contains the subcircuit will be loaded, and the actual subcircuit SPICE listing will be shown on the screen. This technique is also applicable to all other parts. Clicking on a macro will display the macro circuit or parameter call, and clicking on a primitive will display the Attribute dialog box or the model statement that the part uses.

Caller2: I have been trying to set up initial conditions in my circuit. I have placed IC statements in the inductors and the capacitors and have also used the .IC command but neither of these attempts had an effect. What do I need to do to get the initial conditions to work for transient analysis?

Tech: Disable the operating point. In the Transient Analysis Limits dialog box, there is an Operating Point checkbox. Make sure that this is disabled before running an analysis and the initial conditions will work. When the operating point is enabled, MC5 tries to find a DC starting point for the analysis. This operation will override any values that have been declared as initial conditions.

Caller3: In transient analysis, I am getting a strange oscillation in my circuit that I know should not be there. Also, the oscillations are very jagged. What can I do about this?

Tech: Click on the menu sequence Scope/View/Data Points. This marks the actual data points that were calculated during the simulation. If there is a data point at the extremes of these oscillations, but none in between, these oscillations are probably due to trapezoidal integration error. You would need to tighten the numerical integration for this simulation. This may be done by either decreasing the Global Setting Reltol or by decreasing the Maximum Time Step value available in the Transient Analysis Limits dialog box. This will force MC5 to take more data points which should get rid of the oscillations.

Caller4: When I view the current through a resistor in either Probe analysis or by using the expression I(R1) in my analysis limits, the polarity of the current is reversed from what I expect. Why is it giving me these results?

Tech: In SPICE, the resistor, inductor, and capacitor all have polarity. SPICE uses this polarity in order to determine the polarity of the current and voltage that is present through the part. If your waveform is reversed, it probably means that the resistor needs to be rotated so that the leads are swapped. To view which side is positive and which is negative, double click on the part while in Select mode. In the Attribute dialog box, enable the Display Pin Names dialog box and hit OK. The pin names for the resistor will now be displayed on the schematic. You may also change the shape of the resistor and capacitor so that they display a + and - just as the inductor does. There are shapes already created for this purpose. Respolar is the shape for the resistor and Cappolar is the shape for the capacitor. You may change the assigned shape in the Component Editor.

Introducing Micro-Cap V Version 2

The latest version of Micro-Cap, Micro-Cap V Version 2.0, will be available for shipping by June 1. This version has many improvements and added features in both its capabilities and its interface. A preview of some of the features follows. Upon request, all purchases of Version 1.0 between 4/1/97 and the introduction date of 6/1/97 will receive a free upgrade.

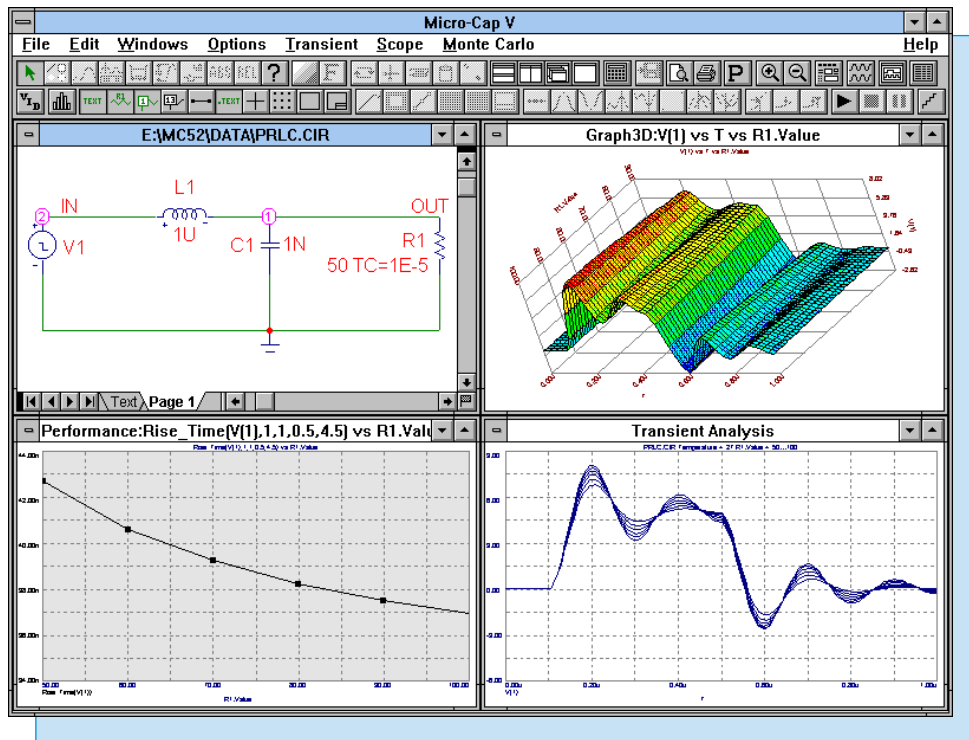

Fig. 1 - Micro-Cap V Version 2.0

Performance Plotting

Performance plotting is a method for displaying data from an analysis that contains multiple runs. MC5 provides a group of functions for measuring performance related curve characteristics. These functions let you measure performance related values such as rise time, fall time, pulse width, frequency, period, and many others. These functions also exist for use in cursor mode, in order to quickly place the cursors across a desired measurement.

Common usage of the performance plotting feature would occur in an analysis that contains temperature stepping or component stepping. For example, the sample circuit PRLC.CIR has its resistor stepped from 50 ohms to 100 ohms in increments of 10 ohms. Performance plotting lets you plot a graph of a characteristic of these curves versus the stepped resistance. Figure 2 is the standard transient analysis output of the PRLC circuit showing the six curves generated by the stepping routine. Figure 3 displays the performance plot of the rise time of the circuit measured between .5 volts and 4.5 volts versus the resistance value.

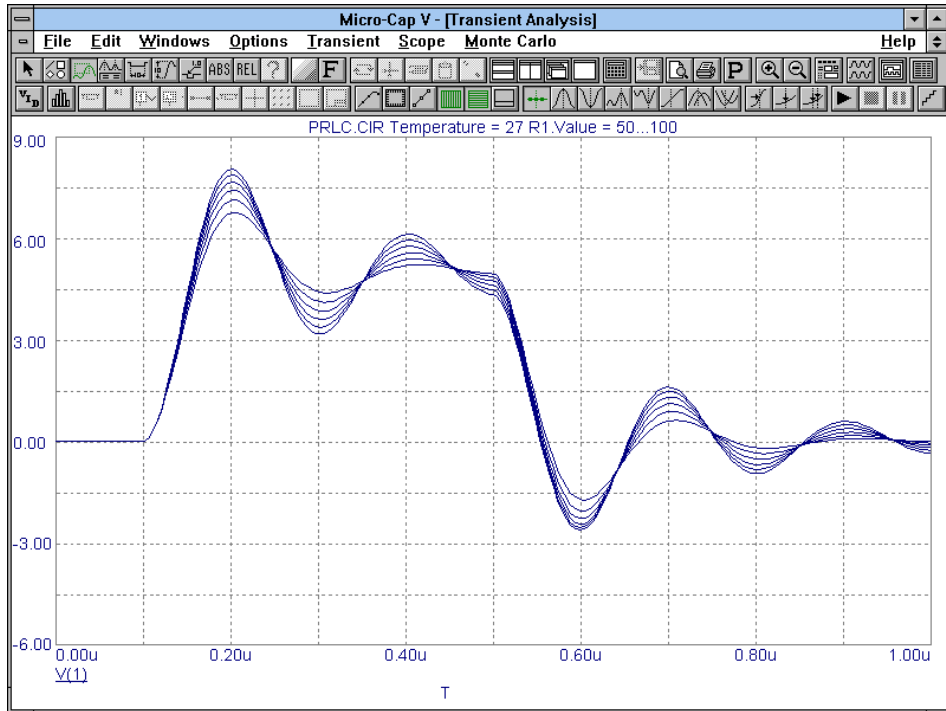

Fig. 2 - Transient Analysis Results

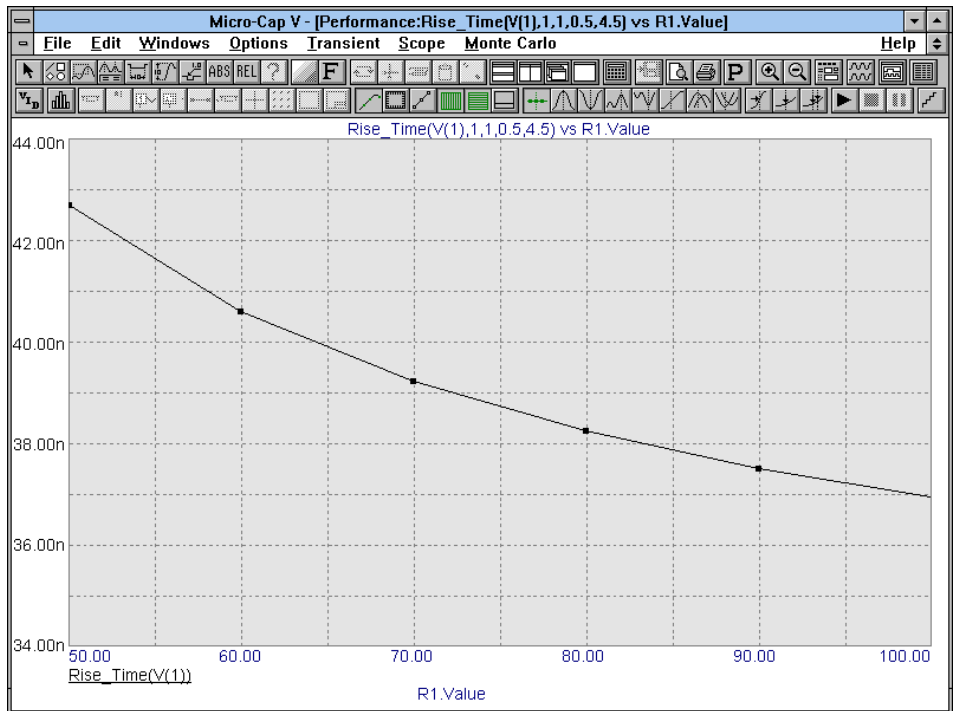

Fig. 3 - Performance Plot: Resistance vs. Rise Time

3D Plotting

Another method for displaying information from a multiple run analysis in Version 2.0 is through 3D plotting. 3D plotting lets you display a plot of three of the variables at the same time. Instead of a single measurement, such as in the performance plot, you can view all of the data in relation to one another. This display method would also be most commonly used in the case of stepping components or stepping temperature.

The appearance of the plot may be altered by the user. The 3D plot may be rotated by mouse or by keyboard. The X, Y, and Z views may all be profiled. The color of the plot is controlled by the user, and it may vary from a spectrum of colors, to a single color, to a wire mesh representation of the plot. Instead of the standard 3D plot, a contour plot may also be produced with the same information.

An example of 3D plotting appears in Figure 4 below. Once again, the circuit PRLC was used. This time the capacitor was stepped from a value of 1n to 6n in increments of 1n. The 3D graph displays a plot of capacitance versus time versus the voltage at node 1.

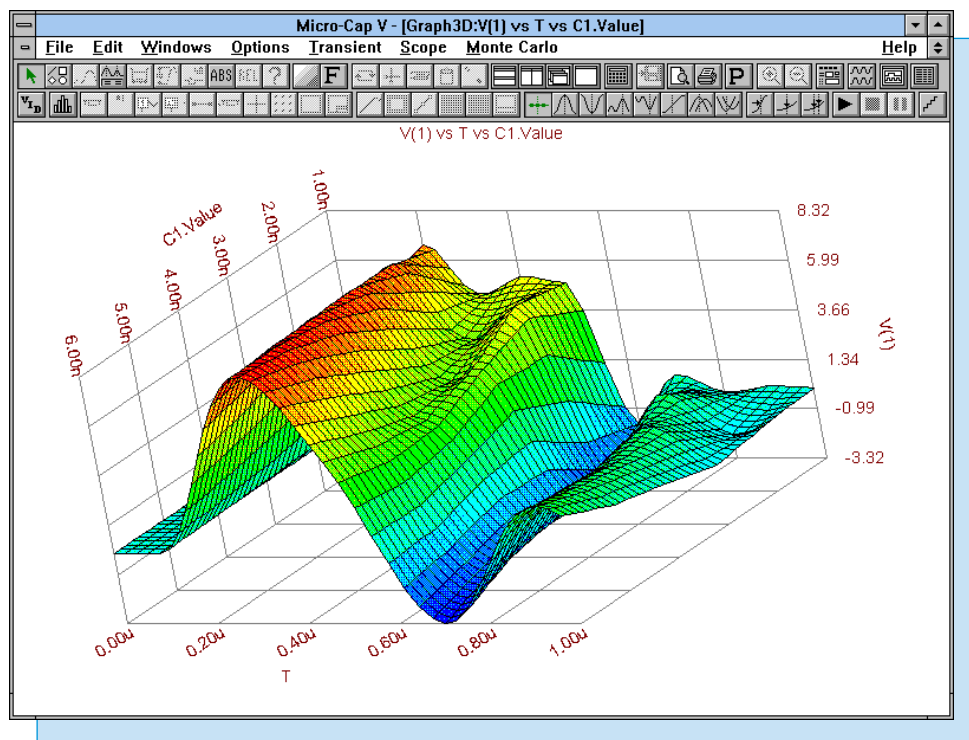

Fig. 4 - 3D Plot

Stepping Improvements

There have been major additions to the stepping routines in Version 2.0 that greatly enhance their capabilities. First of all, symbolic stepping has been added. Any variable that is defined through a .define or a .param statement may now be stepped. This gives you the power to step constants in an equation, or to step multiple parameters that reference the same value. For example, the P2 and P3 parameters of a pulse source may be defined with the same symbolic name. Stepping this name would let you step the peak of a triangle source.

A second feature added was to include a List method along with the standard Log and Linear methods. The List method lets you place a list of values into the Stepping dialog box that the parameter will be stepped through. Any set of values may be stepped now instead of having to have it be linearly or logarithmically related.

The final feature added was to include the capability of stepping multiple parameters. Version 2.0 may step up to 10 parameters in the same analysis. These parameters may be stepped in either a nested or simultaneous mode. Any combination of component parameters, model parameters, or symbolic parameters may be stepped together.

Figure 5 displays the Stepping dialog box as it appears in Version 2.0.

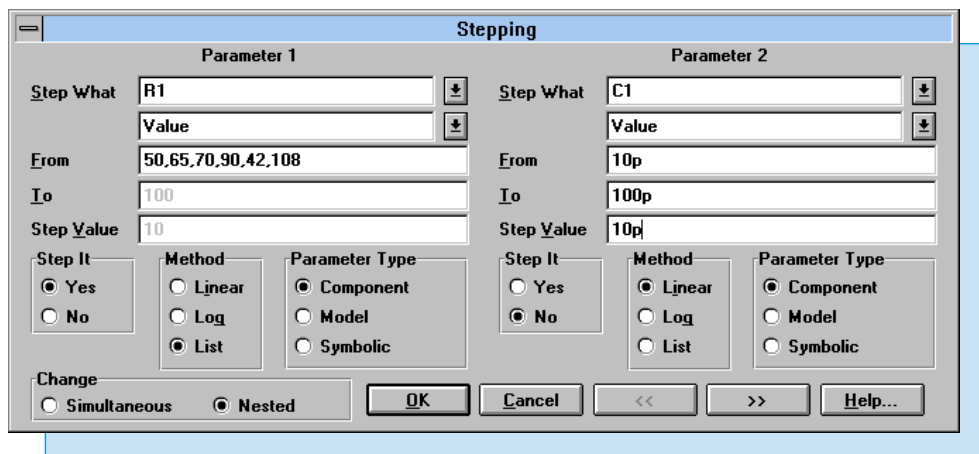

Fig. 5 - Stepping Dialog Box

Larger Model Library

The device model library has now been expanded to over 10000 parts. The digital library now includes over 100 ECL parts from National and Motorola, and the number of parts in the existing families have all been increased. The analog portion of the library has been expanded with European and Japanese diodes and transistors along with current regulators from Motorola. New vendor supplied subcircuits include sensors from Motorola, varistors from Siemens, MosFETs from Harris, and IGBTs from International Rectifier.

New Device Models

New device models that have been added in to the analog primitives are z-transform sources and a sample and hold element. We have also added in the BSIM MosFET models. The BSIM levels added are BSIM1, BSIM2, and BSIM3 Version 3.

Probe Improvements

The Probe method of analysis has undergone some major changes. The basic operation of clicking on the schematic to call up a waveform is the exact same. However, the user now has much more control of the placement and visual attributes of the waveform. There is now a Graph option which performs the same function as the P column in the Transient Analysis Limits dialog box in that it lets you place probed waveforms on up to nine different graph groups. A big advancement in Probe is that it now lets you enter expressions to be plotted. It can handle any of the expressions that the standard analysis uses. Figure 6 displays a Probe analysis in which the waveform $IC(Q5)*VCE(Q5)$ has been plotted.

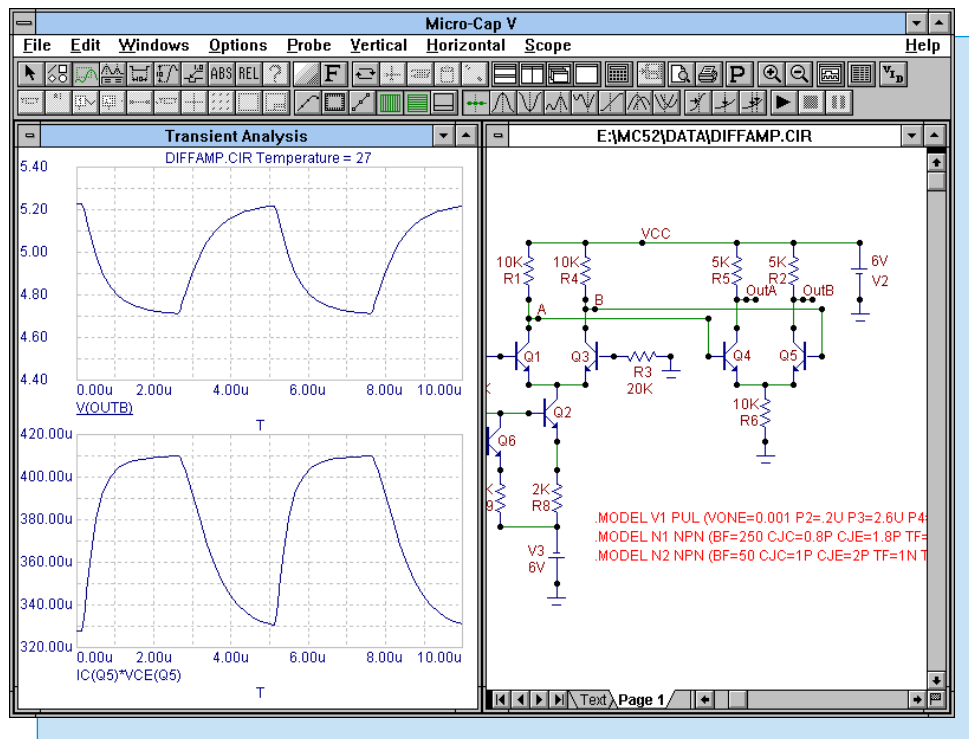

Fig. 6 - Probe Analysis of Diffamp.cir

Improved Waveform Controls

Version 2.0 offers a lot more capabilities in manipulating a waveform after it has been plotted. These changes apply to both standard analysis and Probe analysis. It is now possible to have multiple Y scales for a single graph, and the ranges on these Y scales and on the X scale may be manually changed after the waveform is plotted. You may transfer waveforms from one plot group to another, or simply have the waveform not displayed in case it interferes with another waveform. Finally, it is possible to change the thickness of the waveform in order to improve its visibility on printouts or on the monitor.

Animation

There have been a few new parts added into Version 2.0 to help with digital analysis. These parts act in conjunction with our new animate options. The animate options tell the simulator to produce one data point each time a key is pressed or when a specified length of time has elapsed. The new parts added are a seven-segment display, a digital LED, and a digital switch. These parts change their display or respond to clicks during a simulation. The digital switch lets you toggle an input between 0 or 1 during the simulation while the seven-segment and the LED produce displays on the schematic that indicate what state is present. The seven-segment and LED are for display purposes only. They will have no effect on the simulation.

Figure 7 displays a circuit using the seven-segment display.

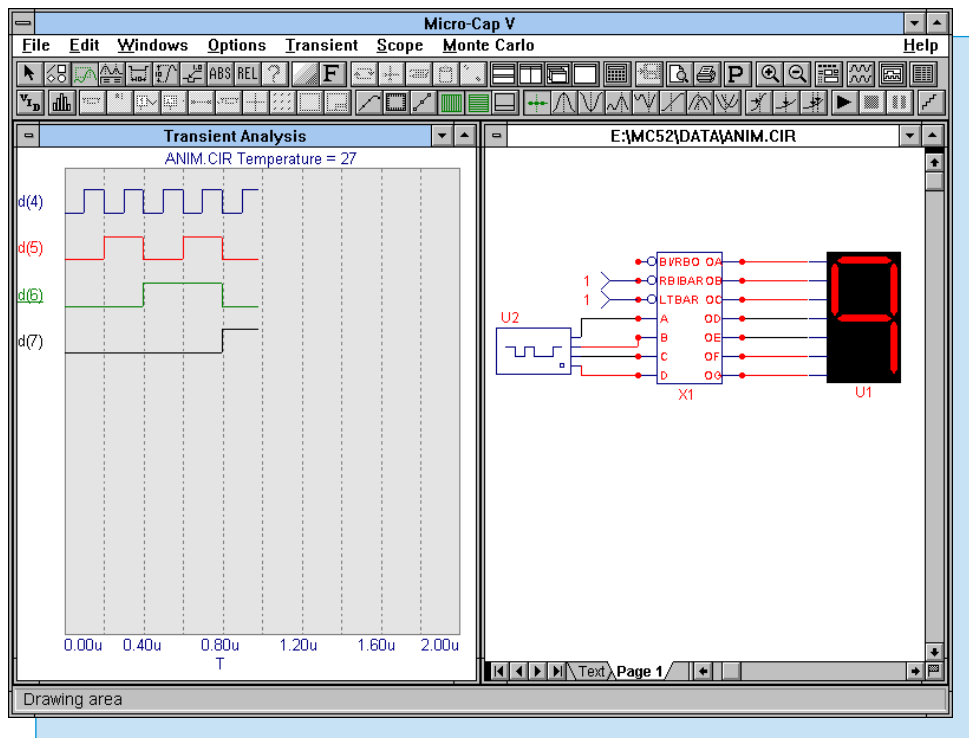

Fig. 7 - Seven Segment Display Animation

Improved Component Selection

There are two new ways to select components in Version 2.0 besides the Component menu and the Component palettes. At the bottom of the Component menu will appear the last ten components that have been used. This lets you have quick access to the most recently used components. There is also a Find Component command now. This command lets you locate a part by its name. For example, if you specify 2N as the search attribute, then this command will return all parts that begin with 2N to choose from. If you specify 2N2222, then that part will immediately be available for placement in the schematic.

Frequency Dependent Elements

Version 2.0 has added the capability for some components to vary with frequency during an AC analysis. The resistor, capacitor, inductor, and nonlinear function sources all have an additional attribute called **FREQ**. This attribute may accept any equation that uses *f* (frequency) as a variable. When running AC analysis, the component will use the frequency that is specified in the frequency range text field in the AC Analysis Limits dialog box. This feature enables you to easily simulate circuit characteristics such as skin effect.

Figure 8 shows an analysis comparing the output of an ideal RLC circuit (red waveform) with the same RLC configuration that takes into account the skin effect of the resistor (blue waveform). The example circuit and equation used were taken from the Summer 1996 newsletter.

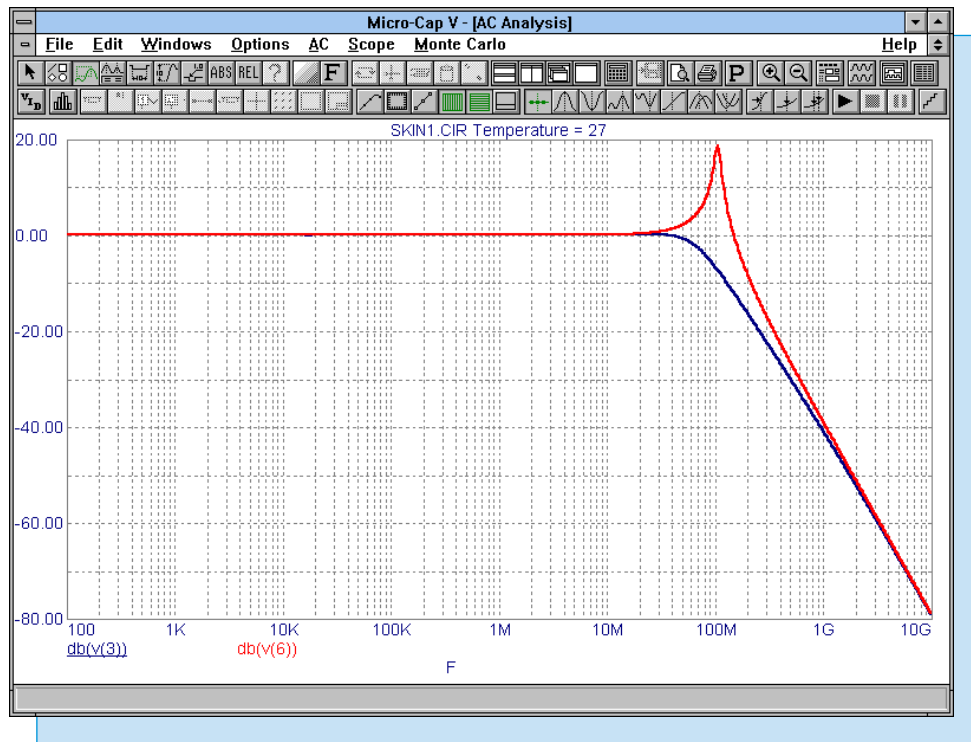

Fig. 8 - Skin Effect Analysis

.Define Macros

Another new feature is the ability to create mathematical macros using `.define` statements. These macros may be used as expressions in an analysis or in defining a component. For example, the following line:

```
.define PB(Q) IC(Q)*VCE(Q)+IB(Q)*VBE(Q)
```

describes an equation for the power dissipation in a BJT. In transient analysis, you may choose to plot the waveform `PB(Q2)` which would then plot the power dissipation through the transistor `Q2`. These macros can be local if placed in the text area or global if placed in the User Definition page.

New Expressions

There have been quite a few new expressions added into Version 2.0. Among these new expressions are the hyperbolic functions - $\cosh(x)$, $\sinh(x)$, and $\tanh(x)$, a table function - $\text{table}(x)$, a step and impulse function - $\text{stp}(x)$ and $\text{impulse}(x)$, integration and derivation operators - $\text{sdt}(u)$ and $\text{ddt}(u)$, and relational operators - $\text{min}(x,y)$, $\text{max}(x,y)$, $\text{limit}(b,x,y)$, and $\text{if}(b,x,y)$.

Monte Carlo Improvements

Monte Carlo analysis has a few new improvements. First of all, it uses the performance functions which measure rise time, fall time, pulse width, period, and more. It is also possible now to define a boolean equation that sets a limit on the Monte Carlo analysis. Any of the Monte Carlo runs that violate this limit are saved to the text output file. This file may then be loaded into MC5, and MC5 will recreate the circuit that caused the failure. Finally, it is now possible to create multiple histograms after the run.

Schematic Improvements

Quite a few features have been added to the schematic editor. The same text name on different nodes now connects the nodes, simplifying schematic connections. It is now possible to edit the model statement for a component from the Attribute dialog box. When browsing through the Open File dialog box, the selected schematic is displayed in the background window. There is now an option to invoke Rubberbanding. This feature lets you move parts in the schematic while maintaining the same connections. The color palette has been increased from 16 to 64 colors for both the schematic and the analysis plot.

Analysis Improvements

Besides the features mentioned earlier in the article, we have added Gear integration in addition to the current Trapezoidal integration. This is an option that may be chosen in the Global Settings. There is a pop-up list available in the Analysis Limits dialog box that lets you access available variables and functions easily. A new data point reduction algorithm has been added. For example, you may save every third data point calculated. For simulations with many data points, this will speed up both redrawing and printing. AC analysis has a new feature in which it may read from a state variables file instead of calculating an operating point. For circuits that have trouble converging in AC, you can run transient analysis until it hits its steady state, and then use that point to begin the AC analysis. A Print Preview has been added to the analysis. This preview lets you scale and print copies of the analysis, histograms, performance plots, 3D plots, and the schematic. Any combination of these may be printed on the same page.

Graphical Capability Improvements

Version 2.0 has improved export abilities to other programs. You can select only part of a circuit with the select box, and then copy that portion into the Windows clipboard in BMP format. Version 2.0 also lets you create Windows Metafiles of the entire window, circuit or analysis. The Metafiles may be saved in a file or sent to the clipboard where they may be pasted into programs such as Microsoft Word or Adobe Pagemaker. Windows Metafiles may also be imported into the schematic editor. This lets you place graphics such as company logos on your schematic.

All of these additions continue in making Micro-Cap V an easier to use, more powerful simulator.

Sample and Hold Macro

The purpose of a sample and hold macro is to quickly store the amplitude of a sampled input waveform, and then to maintain that amplitude until the next sampling pulse. These parts are used in such cases as sampled-data filters or in taking an analog signal that is to be processed by digital circuitry. For example, the sample and hold circuit would hold the value of an input waveform until it takes the next sample. During the hold time, the held voltage would then be converted into an equivalent digital signal for processing by the digital circuitry.

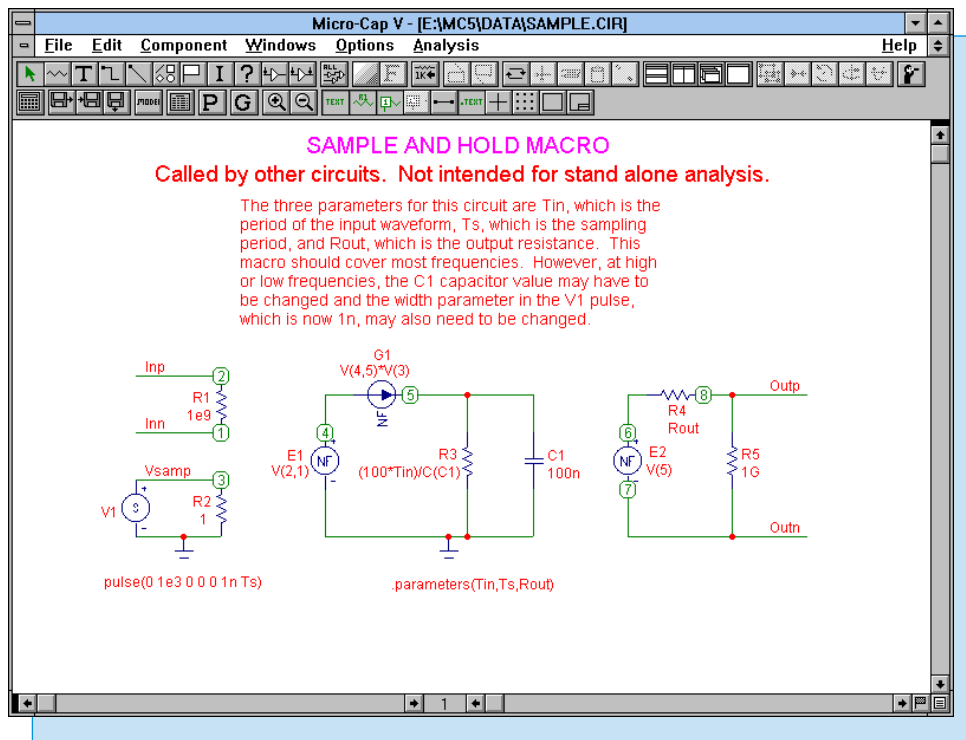

Fig. 9 - The Sample and Hold Macro Circuit

Figure 9 displays the circuit for the sample and hold macro. This macro uses three parameters: T_{in} , T_s , and R_{out} . T_{in} is the period of the input waveform that is to be sampled. T_s is the period of the sampling waveform. R_{out} is the output resistance of the sample and hold macro.

The V_1 independent source will produce a 1ns pulse every T_s seconds. This is the sampling waveform. The current source, G_1 , charges or discharges the capacitor, C_1 , to its next hold value whenever the V_1 pulse is triggered. G_1 will set the capacitor voltage to the value of the E_1 source which is equivalent to the input waveform. When V_1 is not high, the current through G_1 will be negligible. The RC time constant is set at $100*T_{in}$ so that it will be large enough to hold the sampled magnitude without much decay. The E_2 source is then used to buffer the voltage across the capacitor.

This macro can cover a wide range of frequencies as is. It was tested at frequencies between 60Hz and 1MHz. However, if your simulation runs at a frequency that is very high or very low, you may need to modify two of the parameters: the capacitance of C1 and the pulse width parameter of the V1 source.

Figure 10 displays the results of an analysis using the sample and hold macro. The input waveform is a 1MHz sine wave which is being sampled every 90ns. The macro Value attribute is defined as:

```
Sample(1u,90n,1k)
```

The decay during the hold time interval is extremely small. For the hold time interval between 90ns and 180ns, the voltage only decays from 2.703V to 2.701V.

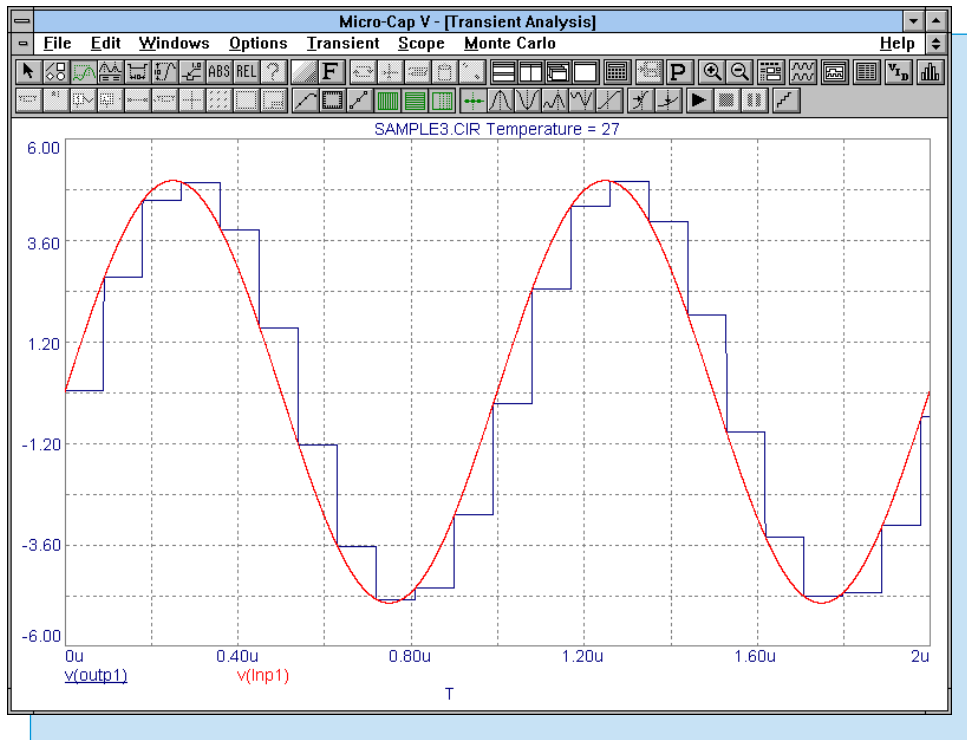

Fig. 10 - The Sample and Hold Analysis

Gyrator Macro

The gyrator is a two port network that is designed to transform a load impedance into an input impedance where the input impedance is proportional to the inverse of the load impedance. The gyrator network can be used to transform a load capacitance into an inductance. This feature is extremely useful in integrated circuit technology where it is nearly impossible to realize physical inductors. The gyrator circuit can be created with just two dependent sources. Figure 11 displays the schematic of the gyrator macro.

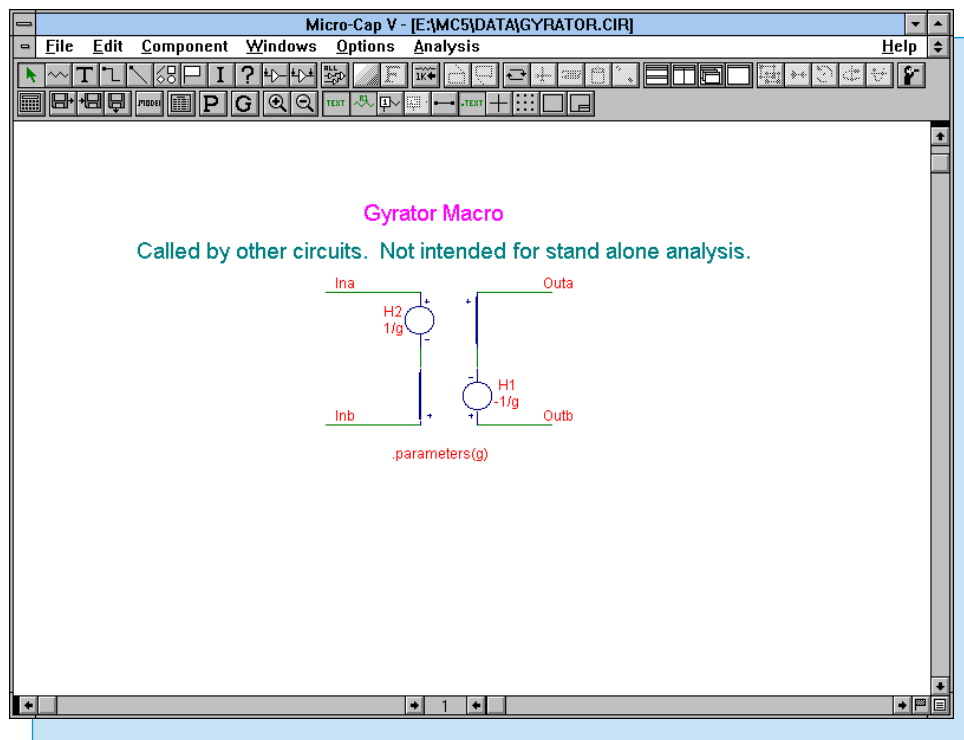

Fig. 11 - The Gyrator Macro Circuit

The gyrator macro consists of just two VofI sources. There is only one parameter in this macro: g . The g parameter defines the gyrator ratio and is used to calculate the gain of the dependent sources. Each source uses the current through the other source as its input. The H1 source has a negative gain because its current input is actually the negative value of the current through H2, and the negative gain will give the two sources the correct opposite polarities.

A test schematic for the gyrator macro appears in Figure 12. The test schematic compares two equivalent circuits: one using an inductor and one using a gyrator and a capacitor. The equation for a gyrator transforming a capacitor to an inductor is as follows:

$$L=C/g^2$$

The 100nF capacitor and gyrator should produce the same output as a 1mH inductor.

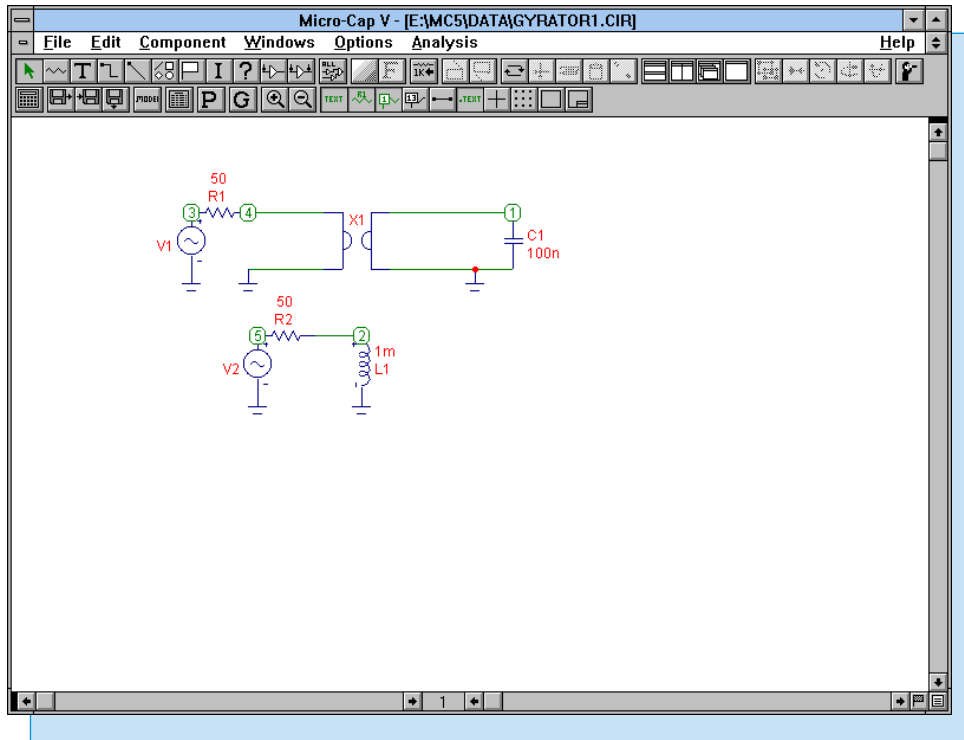

Fig. 12 - The Gyrator Macro Test Schematic

As can be seen in Figure 13, the AC output of the gain and the phase for both circuits produce the same results.

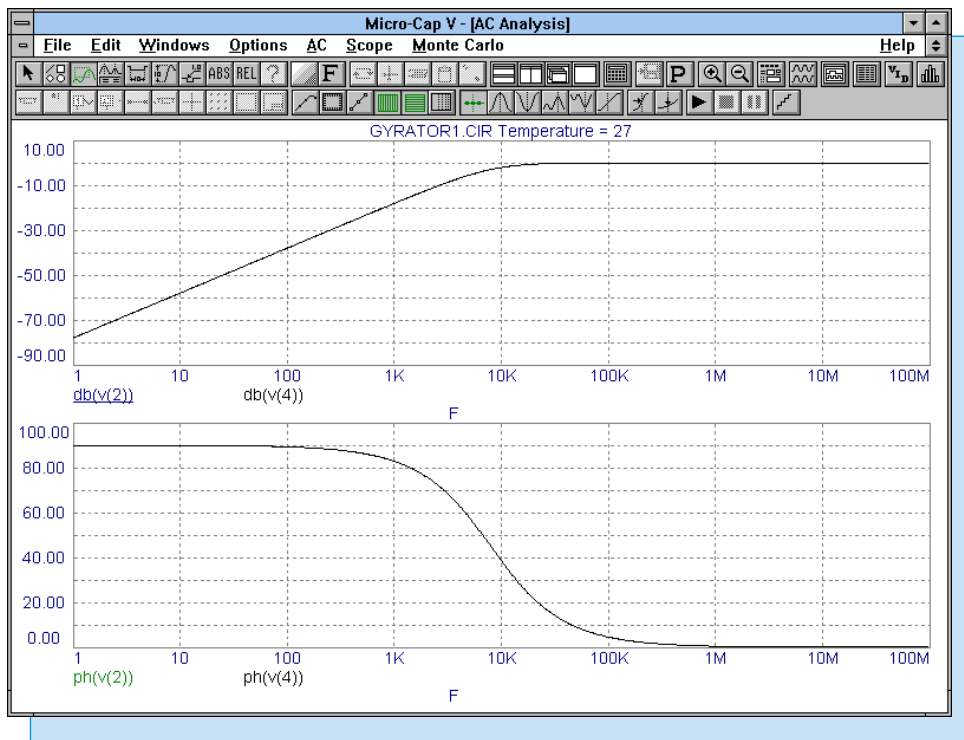

Fig. 13 - The AC Analysis of the Gyrator Test

The Dangers of Aliasing

One problem that occasionally comes up in simulation is that of aliasing. MC5 will calculate a certain number of data points based upon the global setting Reltol, the Maximum Time Step in the Transient Analysis Limits dialog box, and the circuit configuration itself. The minimum amount of data points that will be calculated is 50. To produce the waveform, MC5 will interpolate between these data points. Unless enough data points are calculated to reliably reproduce the waveform, important data may be left out of the simulation. When this occurs, the waveform will appear choppy or jagged. The simulation has been undersampled or aliased and needs to be rerun to produce more data points.

The circuit in Figure 14 is simply a nonlinear function source defined with the expression:

$$5*\sin(2*PI*1000*t)$$

This should produce a nice sine wave with an amplitude of 5 volts at a frequency of 1000Hz.

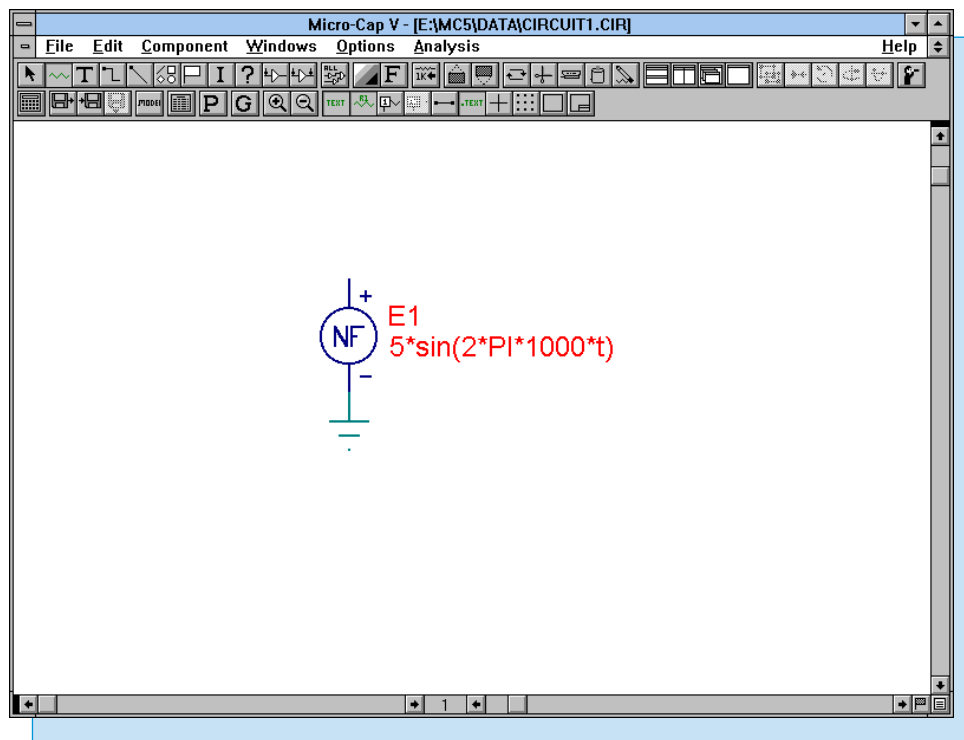

Fig. 14 - Aliasing Circuit

The analysis of this circuit is shown in Figure 15. The simulation has been run for 60ms, and the more cycles of the waveform that are simulated, the worse the aliasing gets. There are no parameters set that force this simulation to take more than the minimum 50 data points, and the results appear extremely choppy with only a vague resemblance to a sine wave. The actual data points produced by this waveform are correct. It is just the interpolation between them that is producing the error. This can be easily seen when looking at the frequency of the waveform. For 60ms, the simulation should be producing 60 cycles, but it appears that only 10 cycles are simulated. The defined frequency of 1kHz now appears to be 166.67Hz. Changing the Maximum Time Step parameter to 6us produces the expected result in Figure 16.

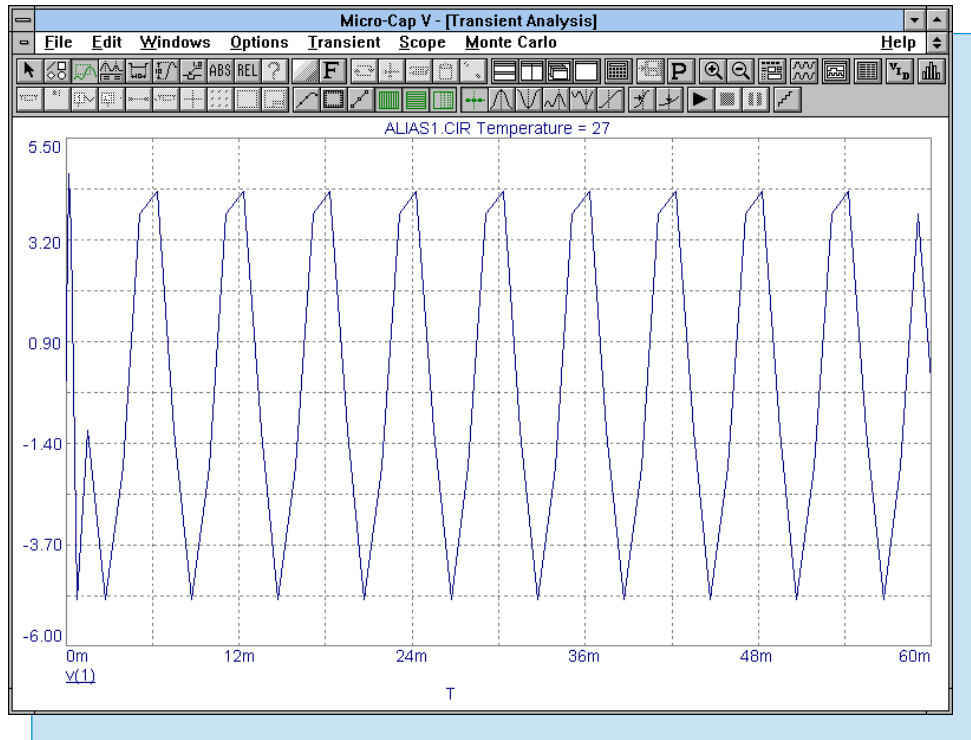

Fig. 15 - Aliased Sine Wave Simulation

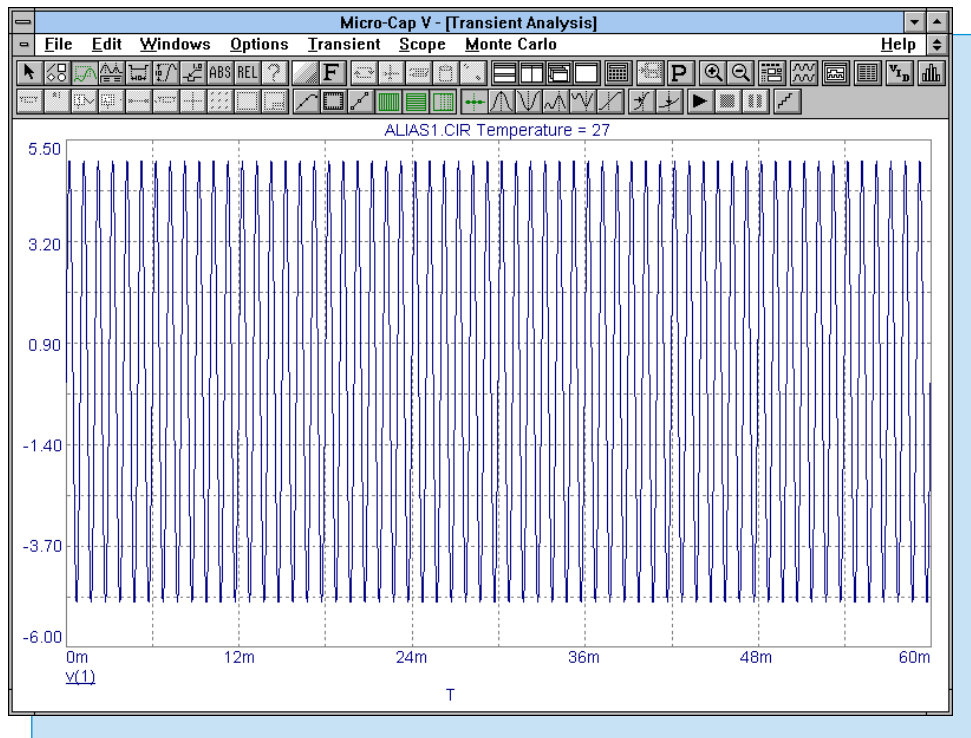

Fig. 16 - Sine Wave Simulation with a 6u Timestep

The previous example would be easy to spot upon simulating the circuit with such an obvious disparity in the frequency and the choppy appearance of the waveform. A related problem, undersampling, occurs when the full amplitude of the waveform doesn't propagate through the circuit. The following is an extreme example of this problem.

Figure 17 displays a series RLC circuit. The input source is a sine source which normally protects well against aliasing as it forces the simulation to produce a minimum of 8 data points per cycle. The input source is a 1 volt, 38kHz sine wave. The resonance of this circuit is also at 38kHz. The simulation, as seen in Figure 18, is run for 10ms producing 380 cycles of the input source.

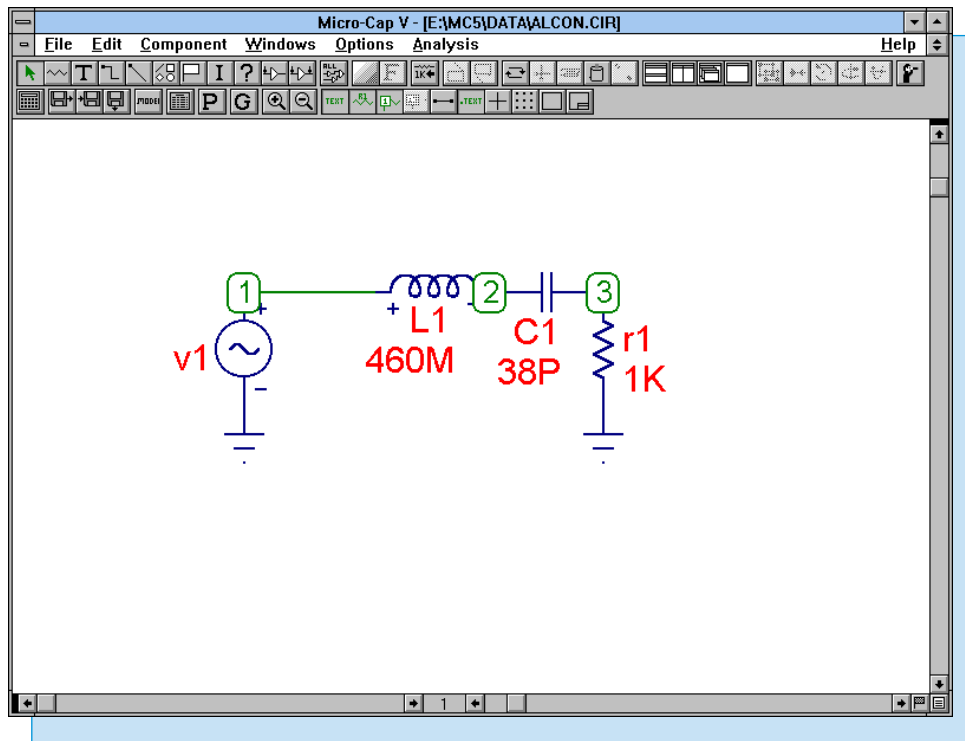

Fig. 17 - Series RLC Aliasing Circuit

If the input waveform had been plotted, a quick glance would make it look like the input was working properly. Only upon zooming in on the waveform would a choppy appearance be seen. The frequency would be correct, but the amplitude of the input would be slightly off at .991 volts instead of 1 volt. This small discrepancy doesn't seem like it would cause a big problem, but it appears that when simulating at resonance, the Local Truncation Error algorithms don't adequately control the internal timestep. This behavior can be observed on any SPICE-based simulator. Setting the Maximum Time Step to .1u produces the expected results in Figure 19. Both of these examples are rare, and the best way to check for this is to view a few cycles of the input waveform to see if it has been sampled as expected.

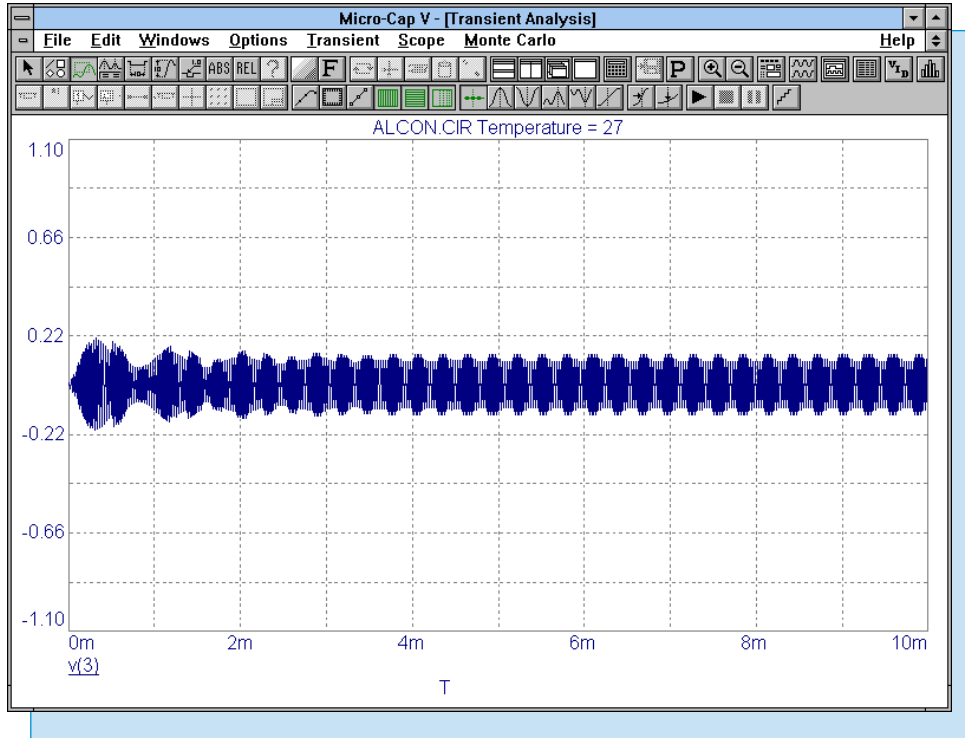

Fig. 18 - Series RLC Aliasing Results

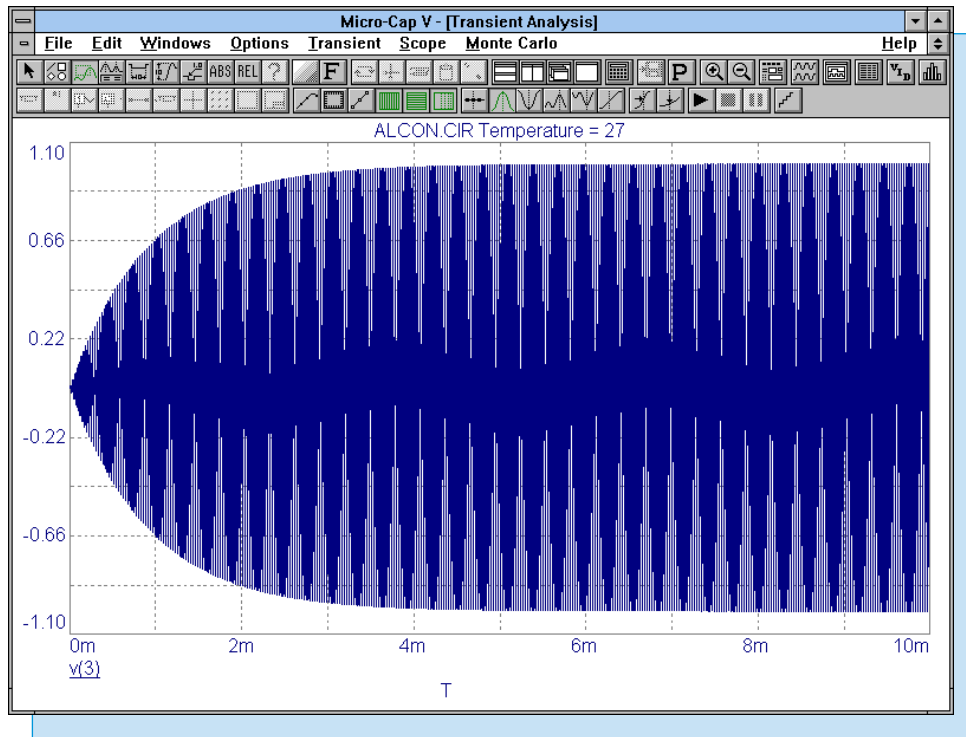

Fig. 19 - Correct Results for the Series RLC Circuit

Product Sheet

Latest Version numbers

Micro-Cap V IBM/NEC Version 1.3
Micro-Cap IV IBM/NEC/MAC Version 3.04

Spectrum's numbers

Sales (408) 738-4387
Technical Support (408) 738-4389
FAX (408) 738-4702
Email sales sales@spectrum-soft.com
Email support support@spectrum-soft.com
Web Site <http://www.spectrum-soft.com>

Spectrum's Products

- Micro-Cap V IBM \$3495.00
- Micro-Cap V NEC \$3495.00
- Micro-Cap IV IBM \$2495.00
- Micro-Cap IV MAC \$2495.00
- Micro-Cap IV NEC \$2495.00

You may order by phone or mail using VISA or MASTERCARD. Purchase orders accepted from recognized companies in the U.S. and Canada. California residents please add sales tax.