

## Summer 2007

### News

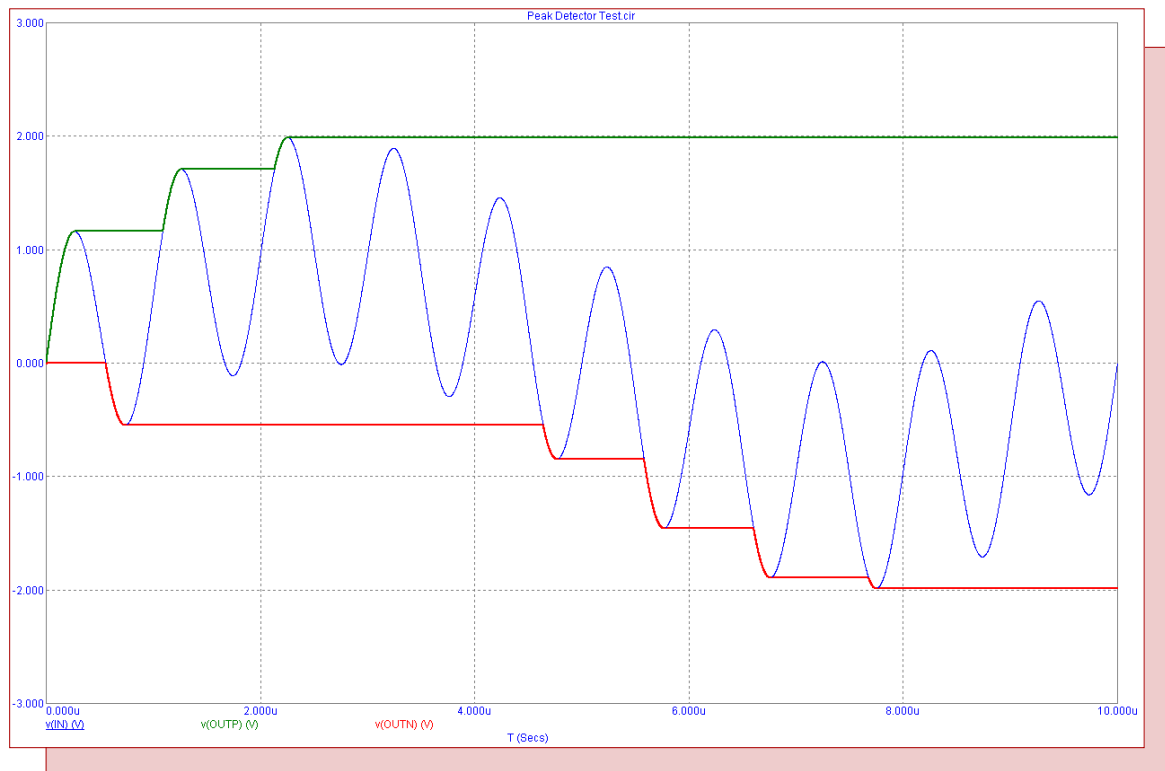

### Peak Detector Macro

Featuring:

- Optimization in Dynamic DC
- Peak Detector Macro
- Using Multiple Shapes and Shape Groups

---

## News In Preview

This newsletter's Q and A section describes the workings of the internal BJT base, collector, and emitter node expressions when used to plot a waveform. The Easily Overlooked Feature section describes the use of the Envelope command to graphically display plot variations of any Monte Carlo or stepped simulation.

The first article describes the use of the optimizer capability in a Dynamic DC analysis. It uses the optimizer to set the current of a Widlar current source.

The second article describes an ideal peak detector macro which can operate with both positive peak and negative peak detection.

The third article describes how to assign multiple shapes to a component and how to use the shape groups to invoke the shapes in the schematic.

## Contents

News In Preview .....	2
Book Recommendations .....	3
Micro-Cap Questions and Answers .....	4
Easily Overlooked Features .....	5
Optimization in Dynamic DC .....	6
Peak Detector Macro .....	9
Using Multiple Shapes and Shape Groups .....	11
Product Sheet .....	16

---

## Book Recommendations

### General SPICE

- *Computer-Aided Circuit Analysis Using SPICE*, Walter Banzhaf, Prentice Hall 1989. ISBN# 0-13-162579-9
- *Macromodeling with SPICE*, Connelly and Choi, Prentice Hall 1992. ISBN# 0-13-544941-3
- *Inside SPICE-Overcoming the Obstacles of Circuit Simulation*, Ron Kielkowski, McGraw-Hill, First Edition, 1993. ISBN# 0-07-911525-X
- *The SPICE Book*, Andrei Vladimirescu, John Wiley & Sons, Inc., First Edition, 1994. ISBN# 0-471-60926-9

### MOSFET Modeling

- *MOSFET Models for SPICE Simulation, William Liu, Including BSIM3v3 and BSIM4*, Wiley-Interscience, First Edition, ISBN# 0-471-39697-4

### VLSI Design

- *Introduction to VLSI Circuits and Systems*, John P. Uyemura, John Wiley & Sons Inc, First Edition, 2002 ISBN# 0-471-12704-3

### Micro-Cap - Czech

- *Resime Elektronické Obvody*, Dalibor Biolek, BEN, First Edition, 2004. ISBN# 80-7300-125-X

### Micro-Cap - German

- *Schaltungen erfolgreich simulieren mit Micro-Cap V*, Walter Gunther, Franzis', First Edition, 1997. ISBN# 3-7723-4662-6

### Micro-Cap - Finnish

- *Elektronikkasimulaattori*, Timo Haiko, Werner Soderstrom Osakeyhtio, 2002. ISBN# ISBN 951-0-25672-2

### Design

- *Microelectronic Circuits High Performance Audio Power Amplifiers*, Ben Duncan, Newnes, First Edition, 1996. ISBN# 0-7506-2629-1
- *Microelectronic Circuits*, Adel Sedra, Kenneth Smith, Fourth Edition, Oxford, 1998

### High Power Electronics

- *Power Electronics*, Mohan, Undeland, Robbins, Second Edition, 1995. ISBN# 0-471-58408-8
- *Modern Power Electronics*, Trzynadlowski, 1998. ISBN# 0-471-15303-6

### Switched-Mode Power Supply Simulation

- *SMPS Simulation with SPICE 3*, Steven M. Sandler, McGraw Hill, First Edition, 1997. ISBN# 0-07-913227-8
- *Switch-Mode Power Supply SPICE Simulation Cookbook*, Christophe Basso, McGraw-Hill 2001. This book describes many of the SMPS models supplied with Micro-Cap.

---

## Micro-Cap Questions and Answers

**Question:** I am plotting the voltage expression V(Q2\_EMITTER) in my simulation but it does not produce the emitter voltage for the Q2 transistor that I expect. When I plot the voltage using the node number at the emitter, the waveform looks correct. Why aren't these two expressions matching?

**Answer:** There are three voltage expressions that may be available for any BJT transistor in order to plot the internal collector, emitter, and base nodes of the device. The expressions take the form of:

V(Part\_Emitter)  
V(Part\_Base)  
V(Part\_Collector)

where Part is the PART attribute name of the transistor. For example, if the PART attribute of the transistor has been defined as Q3, then the expressions would be:

V(Q3\_Emitter)  
V(Q3\_Base)  
V(Q3\_Collector)

These expressions appear when you right click in the Y Expression field to invoke the Variables list. They are available within the Variables / Node Voltage section.

Note that the key point to these expressions is that they plot the internal nodes of the transistor. These expressions are only available if the corresponding lead resistance (RB, RC, or RE) has been defined in the BJT model statement. In your case, the V(Q2\_EMITTER) would produce a value equivalent to the voltage at the emitter node in the schematic minus the voltage drop across the RE resistor for the Q2 transistor.

---

## Easily Overlooked Features

This section is designed to highlight one or two features per issue that may be overlooked among all the capabilities of Micro-Cap.

### Envelope command

In some simulations, it can be quite useful to view the spread of waveforms rather than each individual waveform. This is particularly true in many Monte Carlo simulations where the range of results can be more important than an individual run in the analysis. Micro-Cap has an Envelope command available under the Scope menu that creates a polygon which will encompass all of the branches of a Monte Carlo or stepped run. This command provides a simple way to graphically capture the plot variation. The plot below displays the effect of the Envelope command on a Monte Carlo simulation in AC analysis.

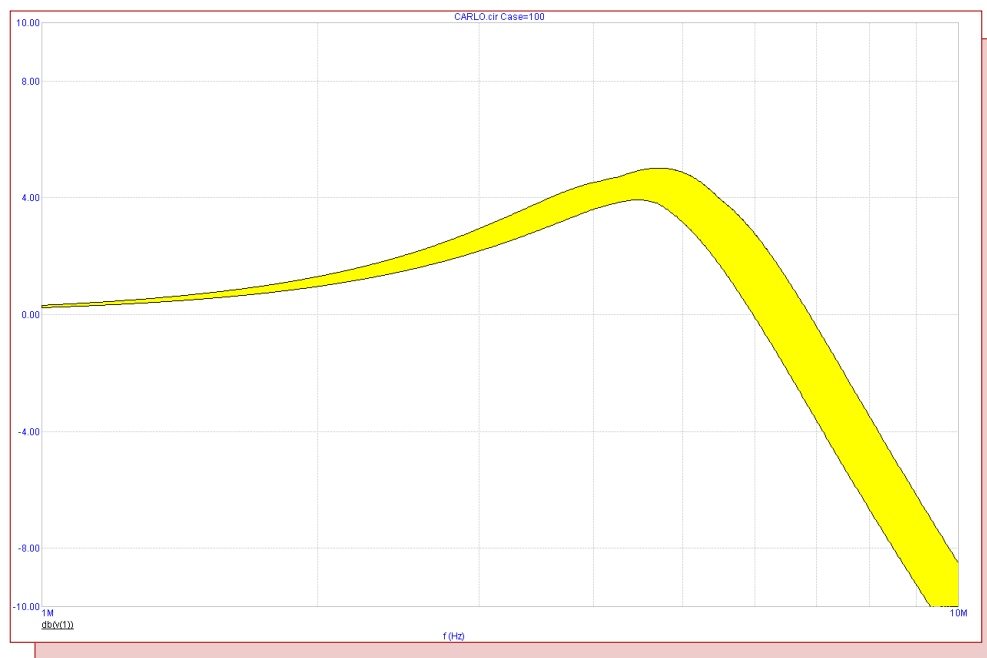

*Fig. 1 - Envelope command used on a Monte Carlo analysis*

The Envelope command is available once the simulation has finished. It creates a closed polygon in the analysis plot that spans the high and low values at each data point. Once created, the polygon is a graphic object in the analysis and can be deleted in the same manner as other graphic objects by selecting it and hitting Delete.

The polygon does not adjust with future runs so to update the envelope for a new simulation, the old polygon would need to be deleted and then the Envelope command would need to be invoked again.

## Optimization in Dynamic DC

The optimizer available within Micro-Cap provides a method to systematically modify component parameters to maximize, minimize, or equate a chosen function of the circuit. The optimizer is available within all analysis modes. In transient, AC, and DC analysis, performance functions are used as the measurement criteria. In Dynamic DC, since the analysis calculates just a single data point, circuit variables such as the voltage at a node or the current through a resistor can be optimized directly. This is very useful for optimizing a circuit to run at a desired bias point. This article will describe the use of the optimizer in Dynamic DC by optimizing a current in a Widlar current source circuit.

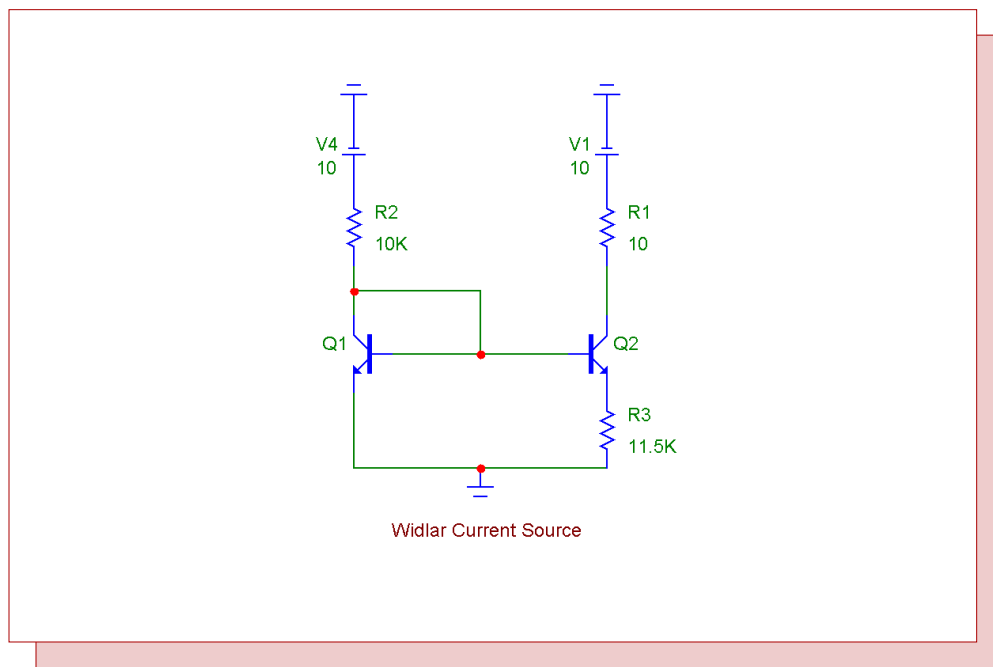

*Fig. 2 - Widlar current source*

The Widlar current source appears in the figure above. The Widlar current source is used to maintain a small current in an integrated circuit in the place of a large resistor since it will occupy a much smaller area of the chip. The two BJTs, Q1 and Q2, are matched transistors. The approximate current that this source produces at the collector of Q2 is defined by the following formula:

$$I_C(Q2) = (V_T/R3) * \ln(I_C(Q1)/I_C(Q2))$$

The above equation is nonlinear and requires an iterative process to calculate the value of the R3 resistor needed to produce the desired collector current at Q2. Rather than going through the tedious iterative process manually, the optimizer available in Dynamic DC analysis can provide a quick answer to what resistance value is needed.

Dynamic DC analysis calculates the DC bias point of the circuit and can display the DC voltage, current, power, and device conditions on the schematic. The Dynamic DC current calculations for the Widlar current source using an emitter resistor with a value of 11.5kohms are shown in Figure 3. With this emitter resistance, the current source generates a current of 10.3uA.

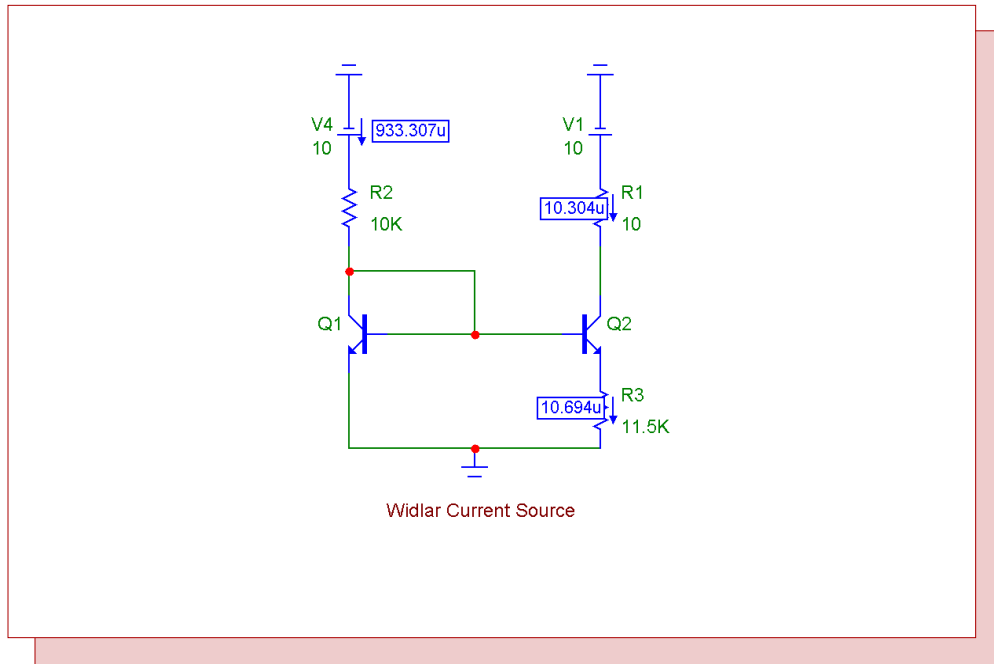

Fig. 3 - Original Widlar current source

Suppose that the specifications of the circuit require the current source to generate 12uA instead. To calculate the new emitter resistance, the Optimize command can be invoked from the Dynamic DC menu. The Optimizer dialog box is displayed below:

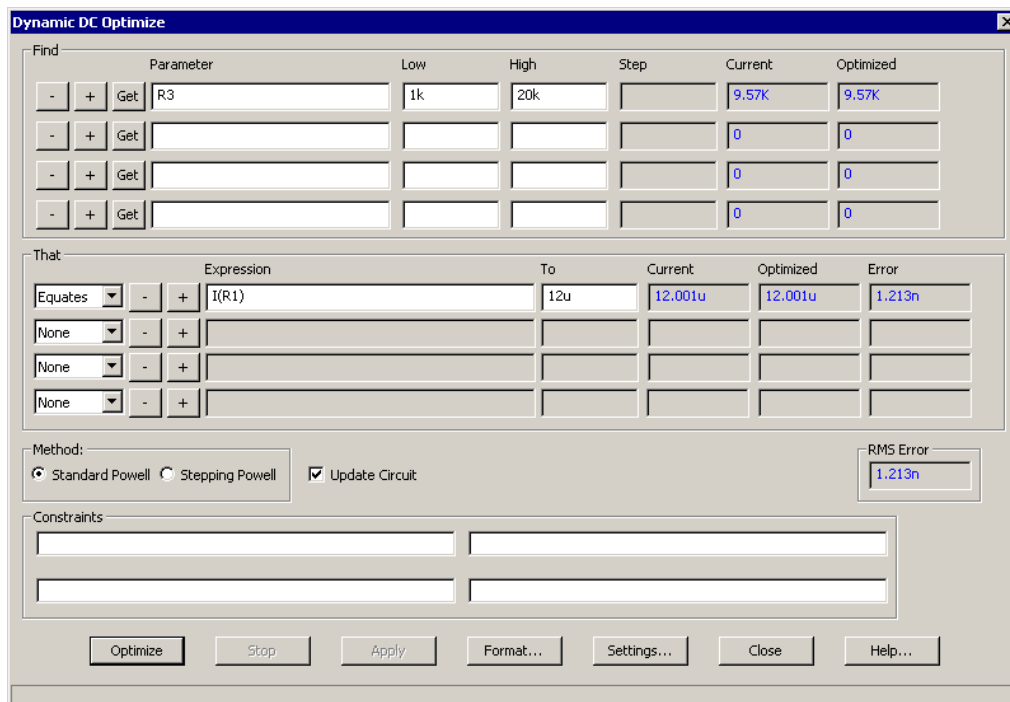

Fig. 4 - Dynamic DC Optimizer dialog box

The Find section of the Optimizer dialog box defines the parameters to be optimized. In this case, the resistance of the R3 resistor will be optimized within the range of 1kohms to 20kohms. That section defines the optimizing criteria to use to find the optimal values of the Find parameters. For this example, the single criteria is to have the current through the R1 resistor, which is equivalent to the collector current in the Q2 transistor, equate to 12uA. In plain English, the optimizer is finding the R3 resistance needed to generate 12uA at the Q2 collector. Clicking the Optimize button initiates the optimization process. The optimized values will be displayed in the dialog box. If the values look good, clicking the Apply button modifies the circuit with the optimized parameters. To generate 12uA, the optimizer finds that the Widlar current source needs its emitter resistor set to 9.57kohms. The schematic below displays the Dynamic DC current calculations with the optimized resistance value.

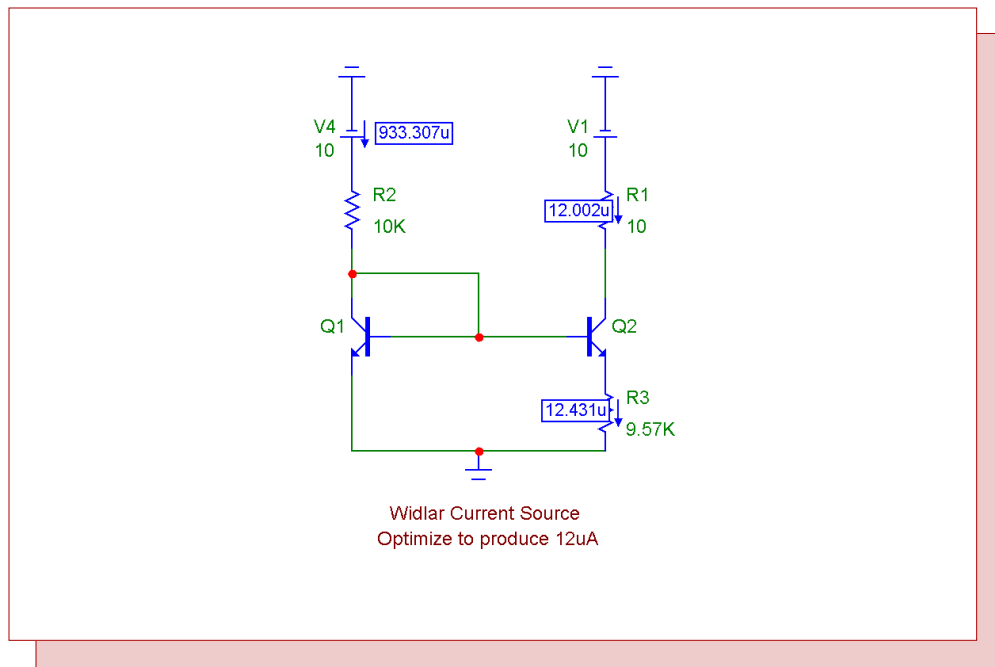

Fig. 5 - Optimized Widlar current source



---

## Peak Detector Macro

Peak detector circuits are used within many types of receivers. A simple peak detector is created from a diode and a parallel resistor-capacitor combination to store the peak voltage. Depending on the RC time constant, this configuration can encounter significant droop error. A behavioral model of an ideal peak detector can eliminate this droop error for simulation purposes. The macro circuit below shows one method for creating an ideal peak detector.

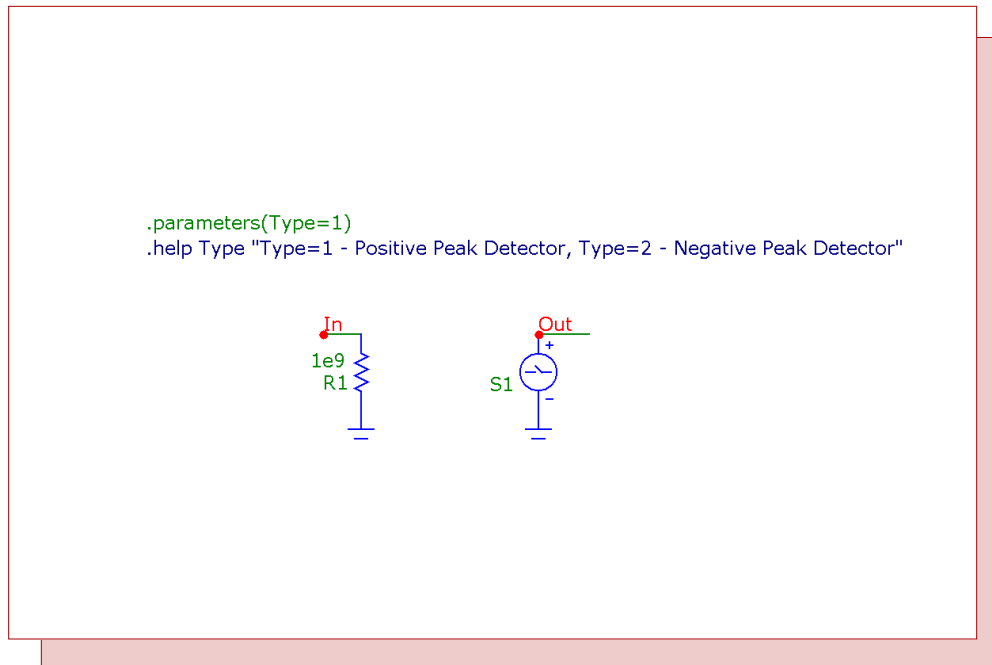

*Fig. 6 - Peak Detector macro*

The peak detector macro has a single parameter passed through to it. The Type parameter defines whether the detector will store positive peaks or negative peaks. When Type is set to a value of 1, the detector will be a positive peak detector. When Type is set to a value of 2, the detector will be a negative peak detector.

The macro circuit consists of just two components. The resistor is present to ensure that there is a DC path to ground at the input of the macro. The Sample and Hold source provides all of the functionality of the detector. The Sample and Hold source has its attributes defined as follows:

```
INPUT EXPR = V(In)
SAMPLE EXPR = TypeExp
```

In the Text page of the macro schematic, the following If statement has been entered to define the TypeExp variable:

```
.if Type==2
.define TypeExp V(In) < V(Out)
.else
.define TypeExp V(In) > V(Out)
.endif
```

If the Type parameter is set to 2, then the first define statement is used to define the TypeExp variable, otherwise the second define statement is used. Since the SAMPLE EXPR is defined for the Sample and Hold source, the source will operate in track and hold mode. For the positive peak detector mode, when the voltage at node In is greater than the voltage at node Out, TypeExp evaluates to true, and the source will track the voltage at node In. When the voltage at node In falls below that of node Out, TypeExp evaluates to false, and the source maintains its last sampled value which will be the highest value of V(In) up to that point of the simulation. The negative peak detector operates in a similar manner except that it samples the input waveform when V(In) is less than V(Out), so that it always maintains the lowest value of the input.

A simple test circuit was created that sums a one volt, 100kHz sine source with a one volt, 1MHz sine source. This summed waveform is then fed into the input of both a positive peak detector and a negative peak detector. The resulting transient analysis is shown below.

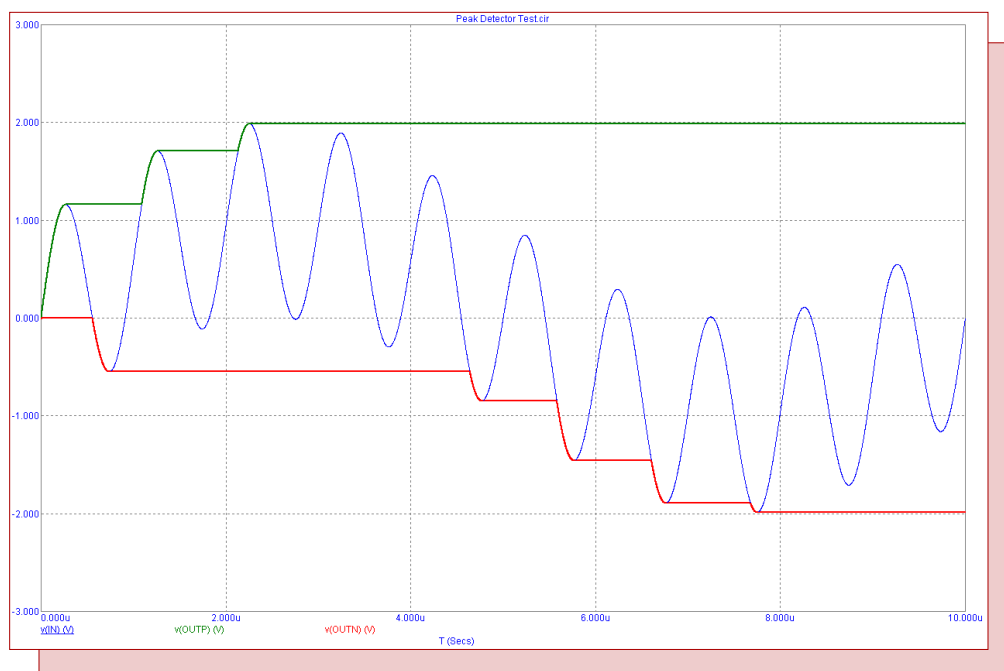

*Fig. 7 - Peak Detector analysis*

The V(In) expression plots the sum of the two sine sources. The V(OutP) expression plots the output voltage of the positive peak detector, and the V(OutN) expression plots the output voltage of the negative peak detector. It is a simple procedure, using Cursor mode, to see that the positive and negative peaks of the input waveform are at 1.988V and -1.988V respectively.

---

## Using Multiple Shapes and Shape Groups

Each component within the component library can have multiple shapes assigned to it for use in the schematic. Whenever a shape is assigned to a component, a corresponding shape group is linked to the newly assigned shape. A shape group typically contains similar groupings of shapes for multiple components. In the schematic, the shapes of the components can be changed by editing the SHAPE-GROUP attribute of the component. The advantage of using shape groups in modifying the component in the schematic is that using the shape group method allows the changing of components en masse. There are five shape groups that have been created with the standard distributed component library of Micro-Cap. They are as follows:

Main - This group is the default group for Micro-Cap. Every component has a shape assigned to it within this group.

DeMorgan - This group contains the DeMorgan equivalent gate symbols for many of the basic digital primitives.

Electrolytic - This group contains an electrolytic shape for the capacitor component.

Euro - This group contains common European shapes for many of the active and passive devices.

Polarity - This group contains symbols that display the polarity for the capacitor and resistor components.

An individual component can have any number of Shape Group:Shape pairs assigned to it. For example, the default settings of the resistor have the following pairs:

```
Main:Resistor
Euro:Resistor_Euro
Polarity:Respolar
```

Setting the SHAPEGROUP attribute for a resistor to Euro will cause that specific resistor to use the Resistor\_Euro shape in the schematic.

### Assigning multiple shapes to a component

All shapes available within Micro-Cap are created in the Shape Editor which is available under the Windows menu. At this point in the article, the assumption is that any shapes to be assigned have already been created in the Shape Editor.

Shapes are assigned to components in the Component Editor which is available under the Windows menu. When a component is selected in the tree on the right hand side of the Component Editor, all of its general properties are available for editing. The Shape entry for each component has two fields. The left field defines the shape group name, and the right field defines the actual shape. Every component will contain a shape group called Main. Components that use just a single shape must have that shape assigned within the Main group.

As an example of adding a shape to a component, the Var\_resist shape will be assigned to the Resistor component. The Var\_resist shape is a symbol of a variable resistor. The first step in assigning this shape is to select the Resistor component from the Analog Primitives / Passive Components section of the component tree. Next, click on the left hand Shape field which will drop down a list of shape groups that are currently defined for the resistor. At the top of this list is the entry <Edit List...>. Click on this entry, and the following dialog box is invoked.



Fig. 8 - Shape Group - Name dialog box

The top section shows the existing Shape Group:Shape pairs for the resistor. Since the Main shape group must be defined for every component, it is not available in this list. Existing pairs can be deleted by selecting them in the list and then clicking the Delete button. The bottom section provides the capability to create new Shape Group:Shape pairs for the selected component.

**Shape Group:** This field defines the name of the shape group to be assigned. Existing shape groups can be selected by clicking the drop down arrow to the right of the field. If a new shape group is to be created, just type in the new name in the field.

**Shape Name:** This field defines the actual shape to be assigned. Clicking in the field provides a list of all of the available shapes.

**Save:** Once a shape group and a shape name have been defined, clicking Save assigns that pair to the component.

For this example, a new shape group will be created. The name VarComp is typed directly into the Shape Group field. Then the Shape Name field is clicked and Var\_resist is selected from the list. Clicking the Save button adds this pair into the list in the top section. Click OK to add this pair to the resistor component. The new shape will now be shown in the Component Editor.

*Note that all shapes assigned to a component should have their connections in the same locations. Moving the pins for one shape will move them for all of the component's shapes, as the pin locations are constant from one shape to another for a component. Create any new shapes so that they use the existing pin locations for the component.*

Closing the Component Editor and saving when prompted now makes this shape available to use with any resistor.

A single instance of a resistor in the schematic can be changed to use this shape, or the shape group VarComp can be given the highest priority in a schematic so that the default shape for the resistor is Var\_resist.

## Modifying a single component

To modify a single instance of the component, simply change the SHAPEGROUP attribute of the device in the Attribute dialog box. For example, double click on an existing resistor to invoke the Attribute dialog box. Highlight the SHAPEGROUP attribute in the list. In the Value field in the upper right hand of the dialog box, click the drop down arrow and a list of available shape groups will be shown as in the figure below.

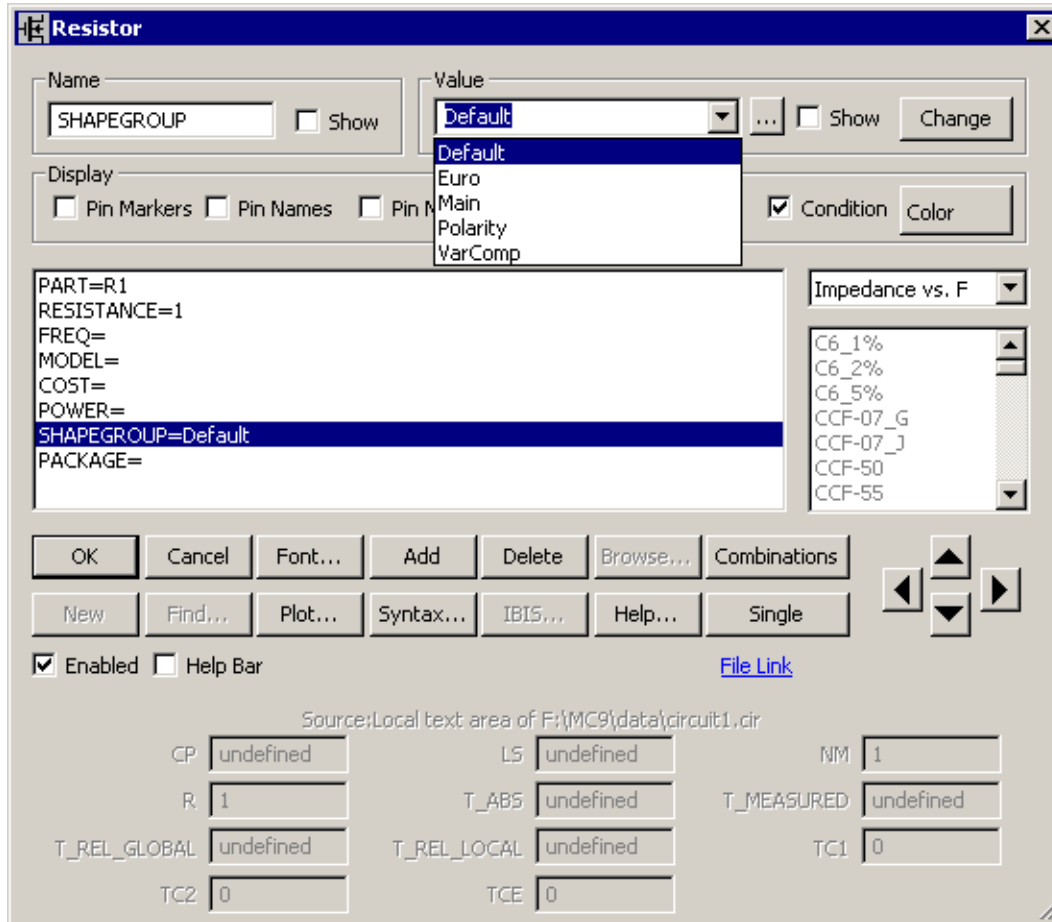

*Fig. 9 - Shape Group list in the Attribute dialog box*

The default SHAPEGROUP attribute value is appropriately enough Default. Default will use the Shape Group Priority list within the Properties dialog box of the schematic. This feature will be discussed more in the next section.

When one of the other shape group entries in the list is selected, the resistor will use the corresponding shape that was defined for that group in the Component Editor.

For our example, if VarComp is defined for the SHAPEGROUP attribute, then that instance of the resistor will use the Var\_resist shape in the schematic. Other instances of the resistor in that schematic will not be affected by this change.

## Changing shape group priority

When a component has its SHAPEGROUP attribute defined as Default, it will use the Shape Group Priority list to determine which shape it will display in the schematic. The Shape Group Priority list is available under the View tab in the Properties dialog box for the schematic. The dialog box is displayed below:

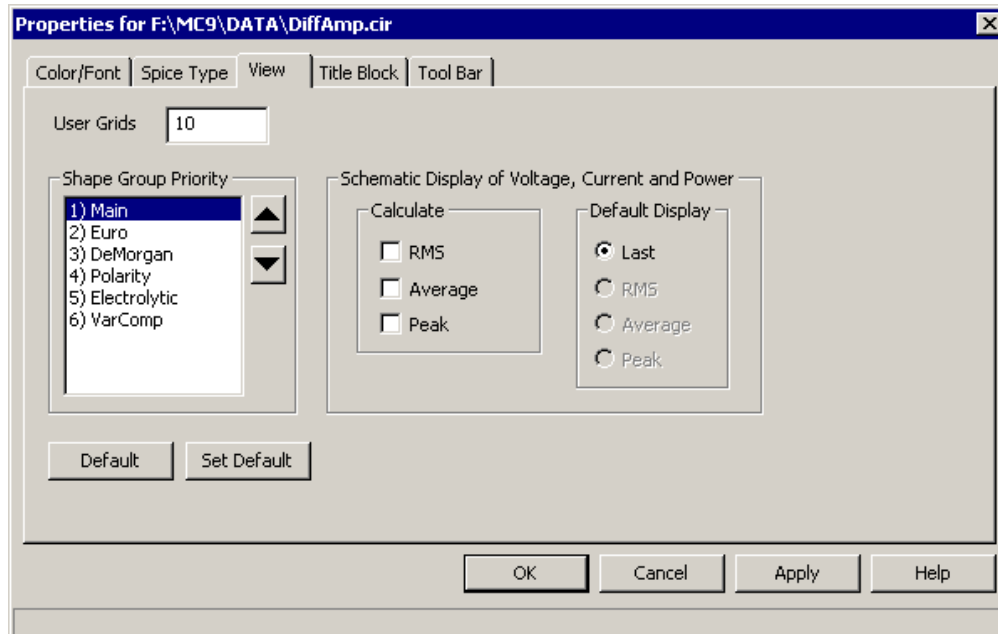

Fig. 10 - Shape Group Priority list in the Properties dialog box

The Shape Group Priority list presents a list of all of the available shape groups. Shape groups can have their priority changed by selecting the group in the list and then clicking the up arrow icon to increase the priority or the down arrow icon to decrease the priority. Each component will start its search at the top of the list. If the component has a shape defined within the first shape group, then it will use that shape. If it does not have a shape defined within that group, it will proceed to the second shape group. If it does not have a shape defined within the second group, it will proceed to the third shape group. It will continue in that manner until it finds a shape group that it has a shape defined within. Since Main will always have a shape defined for every component, any shape group below Main in the list will never be accessed. Any component that has had its SHAPEGROUP attribute modified so it uses a specific shape group will not be affected by any changes in this dialog box.

Changing the priority in the Properties dialog box will only have an effect on that specific circuit. To change the shape group priority for new circuits, go to the Options menu and select Default Properties For New Circuits. Click on the Schematic tab in the upper row and the View tab in the lower row. The list is available to edit here in the same manner as the standard Properties dialog box. This will set the default priority whenever a new schematic is created.

To see how the priority can modify a circuit, load the file Diffamp.cir. Double click in an empty area of the schematic or hit F10 to invoke the Properties dialog box. Click on the View tab. Select the Euro shape group and hit the up arrow button until it is listed as having the highest priority. Click OK. The Diffamp circuit now appears as in Figure 11.

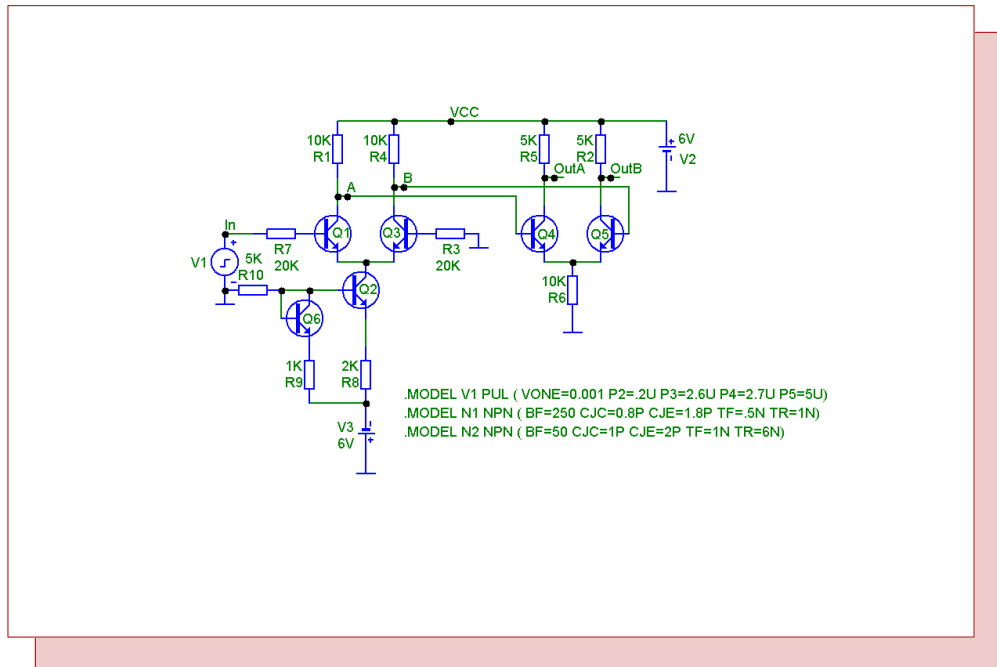

Fig. 11 - Diffamp.cir with the Euro shape group having the highest priority

Nearly all of the components in this schematic have a shape defined within the Euro shape group. Since Euro now has the highest priority, these components will use the corresponding European shapes in the schematic. The Pulse Source is the only component that does not have a shape defined in the Euro shape group. It continues to use the standard pulse source shape defined in the Main shape group.

---

## Product Sheet

### Latest Version numbers

Micro-Cap 9 .....Version 9.0.1  
Micro-Cap 8 .....Version 8.1.3  
Micro-Cap 7 .....Version 7.2.4

### Spectrum's numbers

Sales .....(408) 738-4387  
Technical Support .....(408) 738-4389  
FAX .....(408) 738-4702  
Email sales.....sales@spectrum-soft.com  
Email support .....support@spectrum-soft.com  
Web Site.....http://www.spectrum-soft.com  
User Group .....micro-cap-subscribe@yahoogroups.com