spectrum news

Applications for Micro-Cap™ Users

Fall 2001 Introducing Micro-Cap 7



Featuring:

- Introducing Micro-Cap 7
 - Variable-K Transformer Model
 - Plotting Filter Step and Impulse Response
-
-

News In Preview

This newsletter describes how to model some common components.

The first article introduces the New Micro-Cap 7 and describes some of its new features.

The second article describes a detailed model for the transformer, and outlines a procedure for using a time-varying expression for the K value.

The third article describes the procedure for plotting the step and impulse responses of the filters produced by the Active Filter and Passive Filter routines.

Contents

News In Preview	2
Book Recommendations	3
Micro-Cap 6 Questions and Answers	4
Easily Overlooked Features	5
Introducing Micro-Cap 7	6
Variable-K Transformer Model	14
Plotting Filter Step and Impulse Response	14
Product Sheet	20

Book Recommendations

Micro-Cap / SPICE

- *Computer-Aided Circuit Analysis Using SPICE*, Walter Banzhaf, Prentice Hall 1989. ISBN# 0-13-162579-9
- *Macromodeling with SPICE*, Connelly and Choi, Prentice Hall 1992. ISBN# 0-13-544941-3
- *Semiconductor Device Modeling with SPICE*, Paolo Antognetti and Giuseppe Massobrio McGraw-Hill, Second Edition, 1993. ISBN# 0-07-002107-4
- *Inside SPICE-Overcoming the Obstacles of Circuit Simulation*, Ron Kielkowski, McGraw-Hill, First Edition, 1993. ISBN# 0-07-911525-X
- *The SPICE Book*, Andrei Vladimirescu, John Wiley & Sons, Inc., First Edition, 1994. ISBN# 0-471-60926-9
- *MOSFET Modeling with SPICE Principles and Practice*, Daniel Foty, Prentice Hall, First Edition, 1997. ISBN# 0-13-227935-5

German

- *Schaltungen erfolgreich simulieren mit Micro-Cap V*, Walter Gunther, Franzis', First Edition, 1997. ISBN# 3-7723-4662-6

Design

- *Microelectronic Circuits High Performance Audio Power Amplifiers*, Ben Duncan, Newnes, First Edition, 1996. ISBN# 0-7506-2629-1
- *Microelectronic Circuits.*, Adel Sedra, Kenneth Smith, Fourth Edition, Oxford, 1998

High Power Electronics

- *Power Electronics*, Mohan, Undeland, Robbins, Second Edition, 1995. ISBN# 0-471-58408-8
- *Modern Power Electronics*, Trzynadlowski, 1998. ISBN# 0-471-15303-6

Switched-Mode Power Supply Simulation

- *SMPS Simulation with SPICE 3*, Steven M. Sandler, McGraw Hill, First Edition, 1997. ISBN# 0-07-913227-8
- *Switch-Mode Power Supply SPICE Simulation Cookbook*, Christophe Basso, McGraw-Hill 2001. This book describes many of the SMPS models supplied with Micro-Cap.

RF Electronics

- *Microwave Circuit Design*, Vendelin, Pavio, and Rhoda, First Edition, 1990. ISBN# 0-471-60276-0



Micro-Cap Questions and Answers

Question: How do I plot or print energy?

Answer: In Micro-Cap 6, there are no energy operators but the energy can still be plotted by using the integration operator. See the Questions and Answers column of the Winter 2001 newsletter for information on how to do this.

Energy can be plotted directly in Micro-Cap 7 by using the following syntax:

Energy Generated

Use EG for energy generated or supplied by sources. For example EG(V1) is the energy generated by the source V1. EG by itself is the energy supplied by all sources in the circuit

Energy Stored

Use ES for energy stored in active devices, diodes, capacitors and inductors. For example ES(C1) is the energy stored in the capacitor C1. ES(D1) is the energy stored in the capacitance of diode D1. ES by itself is the energy stored in all capacitors and inductors in the circuit

Energy Dissipated

Use ED for energy dissipated in resistors and diodes and other active devices. For example ED(R1) is the energy dissipated in the resistor R1. ED(D1) is the energy dissipated in the resistive parts of diode D1. ED by itself is the energy dissipated in the entire circuit.

Question:

During a Monte Carlo run, the performance function being used extracts a single value from its target waveform for each run. After N runs are complete, the histogram of the N values is plotted. The individual values can be seen in the list shown to the right of the histogram. The question arises, how can I extract these values and import them to another program?

Answer: From the Monte Carlo menu select the Statistics item. This displays the Monte Carlo Statistics window called circuit.tmc (*.tmc for transient analysis, *.amc for AC, and *.dmc for DC). This window shows the individual values. You can select all values with CTRL+A (or just part of them with the mouse) and copy them to the clipboard with CTRL+C. From there you can switch to another program (such as Excel or Word) and paste them in with CTRL+V.

Easily Overlooked Features

This section is designed to highlight one or two features per issue that may be overlooked because they are not made visually obvious with an icon or a menu item.

Panning

In a large schematic you sometimes want to view a different part. If it is near the currently displayed part, the easiest way to see it is panning and the easiest way to do that is to drag while holding the right mouse button down. This moves the window view. It's like dragging a sheet of paper across a desk. Dragging can also be done with the CTRL + arrow keys. For example, if you hold the CTRL key down and press the right arrow key once it pans the view right about 10% of the screen width.

Rotating a Part with the Mouse or Spacebar

The easiest way to rotate a part is through the mouse or spacebar instead of the Rotate menu item. To rotate a component upon initial placement in the schematic:

- 1) Choose the component that is to be placed.
- 2) Click and hold down the left mouse button to place the component on the schematic.
- 3) Hit the right mouse button or the spacebar to rotate the component through its eight possible orientations while holding the left mouse button down.

To rotate a component that has already been placed in the schematic:

- 1) Enable Select mode.
- 2) Click on the component using the left mouse button and hold the left mouse button down. The component should change to its select color.
- 3) Hit the right mouse button or the spacebar to rotate the component through its eight possible orientations while holding the left mouse button down.

Drag Copy

The drag copy feature is a simplified method to performing a copy and paste. It uses the following procedure:

- 1) Select a circuit object or region to be duplicated.
- 2) Press CTRL and drag on any item in the selected area. Once the drag operation has begun, the CTRL key may be released.
- 3) Release the left mouse button to place the copy.

The original objects are left in the same place, but the copy is dragged along with the mouse. The part names are all incremented in this operation, but everything else will remain the same (with the possible exception of grid text depending on whether Text Increment is enabled in the Preferences dialog box). This feature may be used with any element in the schematic such as components, wires, graphic objects, flags, or text. CTRL+Z will undo a drag copy operation.



Introducing Micro-Cap 7

Micro-Cap 7 has just been released. It has a hoard of new features that are primarily targeted at enhancing ease of use. Many of the new features are derived directly from suggestions made by users. Here are snapshots of a few of the features:

Optimizer

An optimizer was added for use in transient, AC, and DC analysis, provided the capability of minimizing, maximizing, or matching numeric values for any set of performance function expressions subject to specifiable constraints.

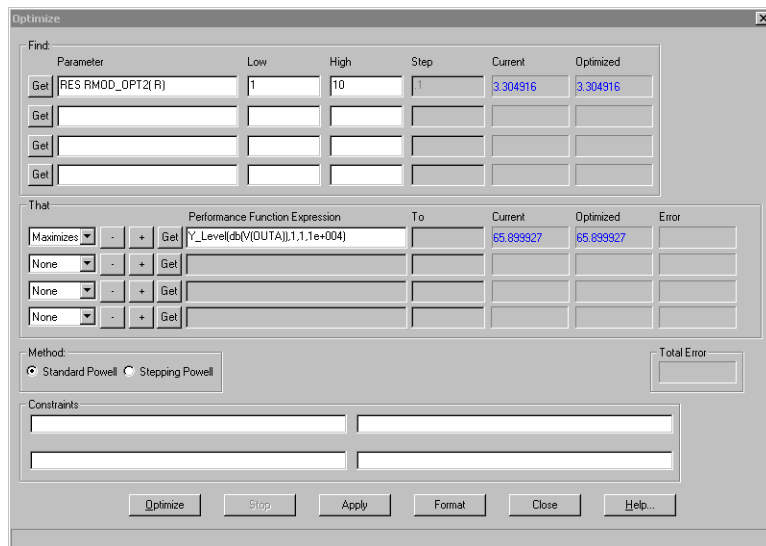

RF models and Smith charts

An S-Parameter two-port analog primitive was added to facilitate the modeling of RF devices. Smith chart and polar plot styles were added to simplify the plotting of S-Parameter data.

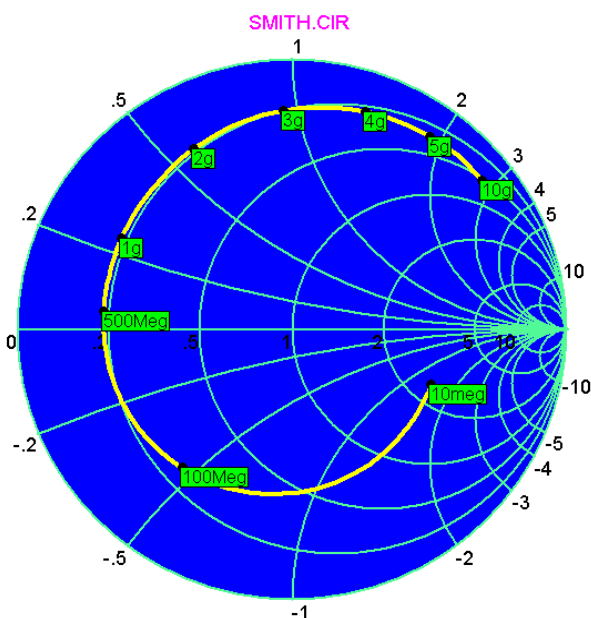

Portable schematic files

Formerly, to send a schematic to a colleague, it was sometimes necessary to transfer not only the schematic file, but the component library file, the shape library file, and any model library files used. In Micro-Cap 7, the schematic file format was expanded to include all information necessary to draw and analyze the circuit. The necessary component, shape, and model library information is stored in the schematic file, so sending a circuit to another user requires only circuit files be sent.

User-specified paths (folders) for all major file groups

User-specified paths (folders) for circuits and libraries were added to allow easy separation of file types. Circuits can be stored in one folder and model libraries in another. Formerly, circuit files and libraries had to be in the current (last opened) folder or in the folder set by the MC6DATA environmental variable.

Characteristic curves

Many users have asked for a stimulus editor that would interactively show the waveform plot as edits are made. We liked the idea so much we added plots for most devices and incorporated it into the Attribute dialog box. Not just waveform sources, but active devices, diodes, Laplace sources, and digital stimulus sources all have characteristic curves or waveforms that can be plotted as you make edits. In the case of analog and digital waveform sources, the characteristic curve is the waveform itself. In the case of BJTs, one or more curves are selectable including DC current gain, saturation voltage, IV characteristics, and beta vs. frequency. Diodes and FETS have IV characteristics plots. OPAMPs have Bode plots.

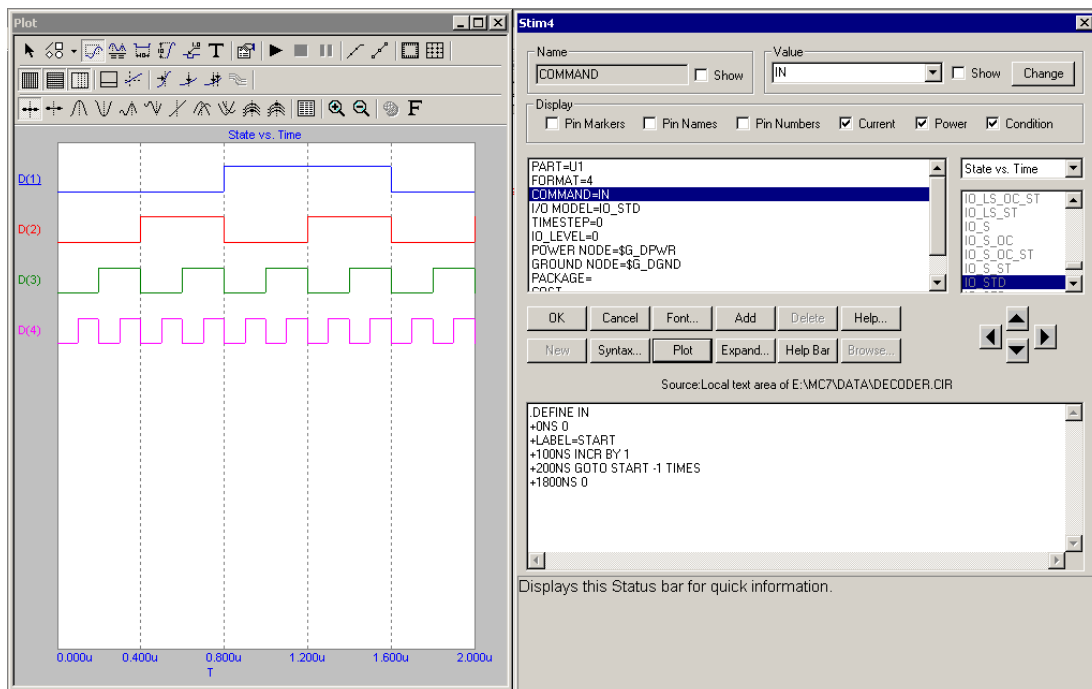

Component editor improvements

The Component editor was significantly enhanced with an Import wizard that scans a model library file for subckts and adds them to the library when it finds existing parts with similar pin names. This provides near-automatic addition of vendor libraries and makes their frequent updates easier to integrate into the libraries. Other improvements include an Add Part wizard, part templates for rapid manual entry of similar new parts, parts count by group, part name alphabetizer, and a part name list generator.

Attribute dialog box editor

The Attribute dialog box (that comes up when you double-click on a part) was changed to allow editing of model parameters, subckts, digital stimulus patterns, and analog waveforms from within the dialog box. This makes the ADB the place for all-in-one viewing, editing, and visualizing model-related data for components.

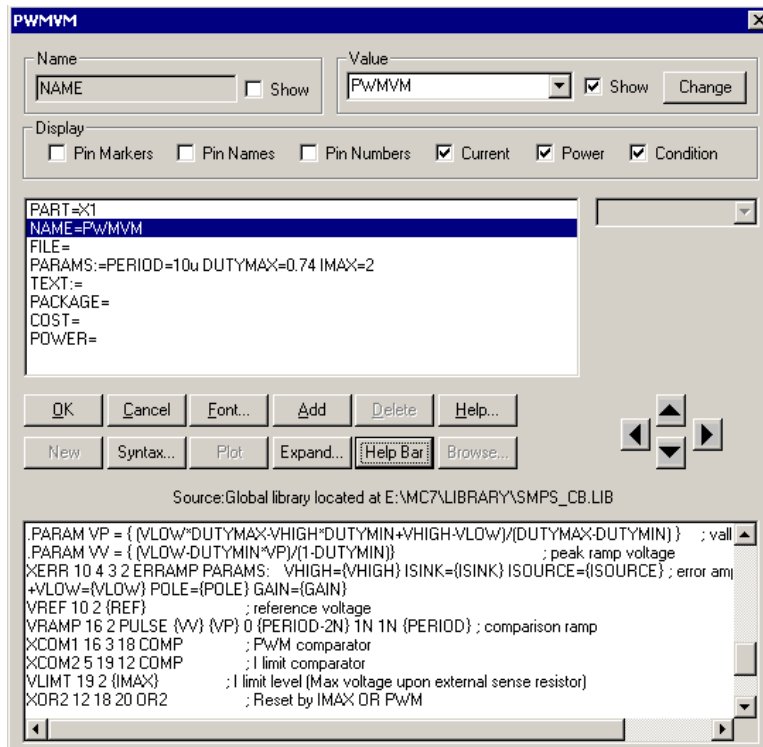

Multistage undo and redo

A multistage undo and redo was added to let you go back and forth one or more schematic steps.

Improved component find command

The component find command was expanded to search on the Name, Shape, Definition, and Memo fields. A Beginning of Line option was added to simplify Memo field searches. A text output of the search results was provided to create custom lists of the library sections.

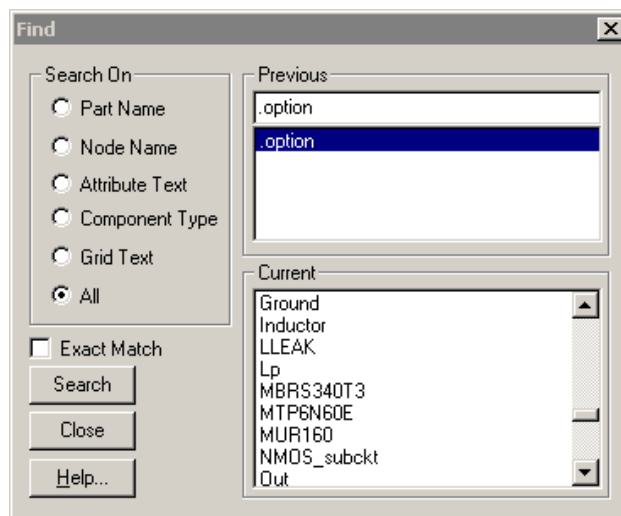

Bill of materials

A bill of materials was added to the program. It lists the number, value, power, cost, and instances, for each electrical part type in the circuit.

Bill of Materials

BP Filter 23.cir Imaging Machines Inc. Jeff Pearson

Item	Type	Value	Qty	Power	Cost	Cost	Parts
1	Battery	15	2	0	0.0000	0.0000	V2,V3
2	Resistor	11K	1	0	0.0000	0.0000	R1
3	Resistor	6.81K	1	0	0.0000	0.0000	R2
4	Resistor	15.8K	5	0	0.0000	0.0000	R3,R10,R17,R24,R30
5	Resistor	38.3K	1	0	0.0000	0.0000	R4
6	Resistor	22.1K	1	0	0.0000	0.0000	R5
7	Resistor	30.9K	1	0	0.0000	0.0000	R6
8	Resistor	10.2K	1	0	0.0000	0.0000	R8
9	Resistor	7.32K	1	0	0.0000	0.0000	R9
10	Resistor	34.8K	1	0	0.0000	0.0000	R11
11	Resistor	20.5K	1	0	0.0000	0.0000	R12
12	Resistor	32.4K	1	0	0.0000	0.0000	R13
13	Resistor	11.3K	1	0	0.0000	0.0000	R15
14	Resistor	6.65K	1	0	0.0000	0.0000	R16
15	Resistor	40.2K	1	0	0.0000	0.0000	R18
16	Resistor	22.6K	1	0	0.0000	0.0000	R19
17	Resistor	30.1K	1	0	0.0000	0.0000	R20
18	Resistor	10K	1	0	0.0000	0.0000	R22
19	Resistor	7.5K	1	0	0.0000	0.0000	R23
20	Resistor	34K	1	0	0.0000	0.0000	R25
21	Resistor	20K	1	0	0.0000	0.0000	R26
22	Resistor	33.2K	1	0	0.0000	0.0000	R27
23	Resistor	147	1	0	0.0000	0.0000	R29
24	Capacitor	22.56295N	1	0	0.0000	0.0000	C1
25	Opamp	OP_07	5	0	0.0000	0.0000	X1,X2,X3,X4,X5

Sanity checker

A model parameter range checker was added to warn when model parameters exceed user-specified "reasonable" limits.

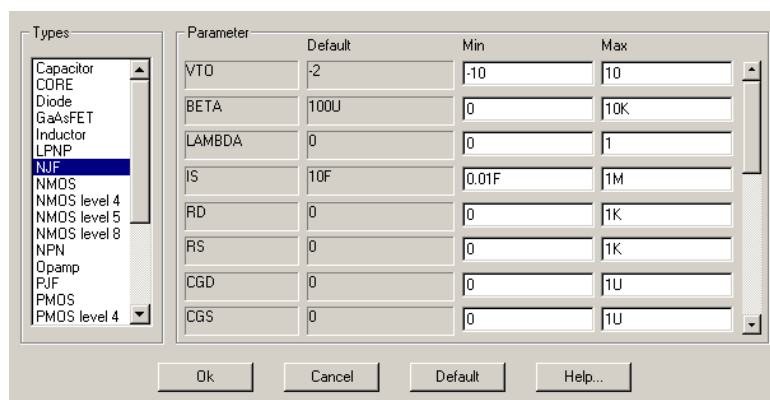

SPICE file probing

Probing, the ability to click on an object and see its curve or waveform, was added to SPICE text files. This was actually added after the original MC6 release and was never in the MC6 manuals.

Analysis plot improvements

Several improvements were made to analysis plots, including the ability to switch between log and linear scales, to select the grid interval and the grid pattern, width, and thickness.

Shape editor improvements

Several improvements were added to the analysis plots, including the shape origin symbols, font size memory, and a drag copy command.

Live formulas

Live on-schematic text formulas were added that automatically update when any edits are made allowing live design formulas. Here for example is a live formula for the resonant frequency of a Colpitts oscillator.

```
.DEFINE C1 1N  
.DEFINE C2 1N  
.DEFINE L1 10U  
2*PI/SQRT(L1*C1*C2/(C1+C2))=8.886E+007
```

New X and Y Scale format

A new scale format, High, [Low], [Step], allows users to specify arbitrary grid intervals (scale divisions). Panning a plot now maintains the minor grid structure for ease of use and readability.

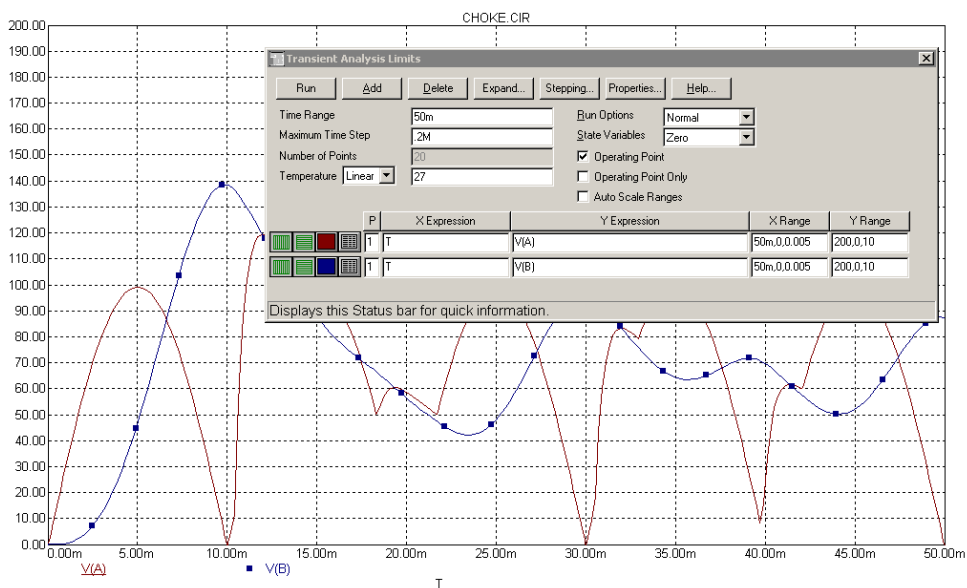

Even decimal values cursor positioning

A new cursor positioning mode was added for placing the cursor on even decimal values of the horizontal axis variable.

Incremental auto-ranging

Y dimension auto-ranging was modified to apply only to the specified X range, not the whole simulation range.

Simultaneous multi-row analysis limits edits

Rapid analysis limits editing was facilitated by allowing users to change all of the rows in a waveform column simultaneously by clicking on the column header.

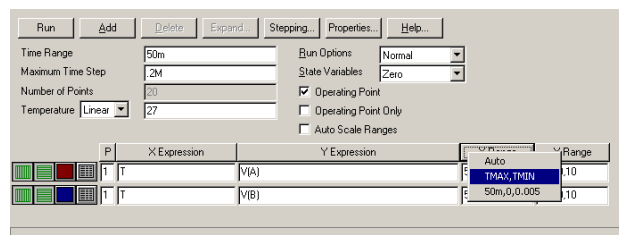

Run-invariant expressions in model parameters

Run-invariant expressions (those that don't change during a run) were added to model parameters. For example, a MOSFET VTO could be expressed as $2.0 + \text{TEMP}/100$ to allow for threshold shift with temperature.

Thumbnail plot

A thumbnail plot was added to provide a global view of enlarged analysis plots, showing the location of the expanded region box superimposed on the whole plot.

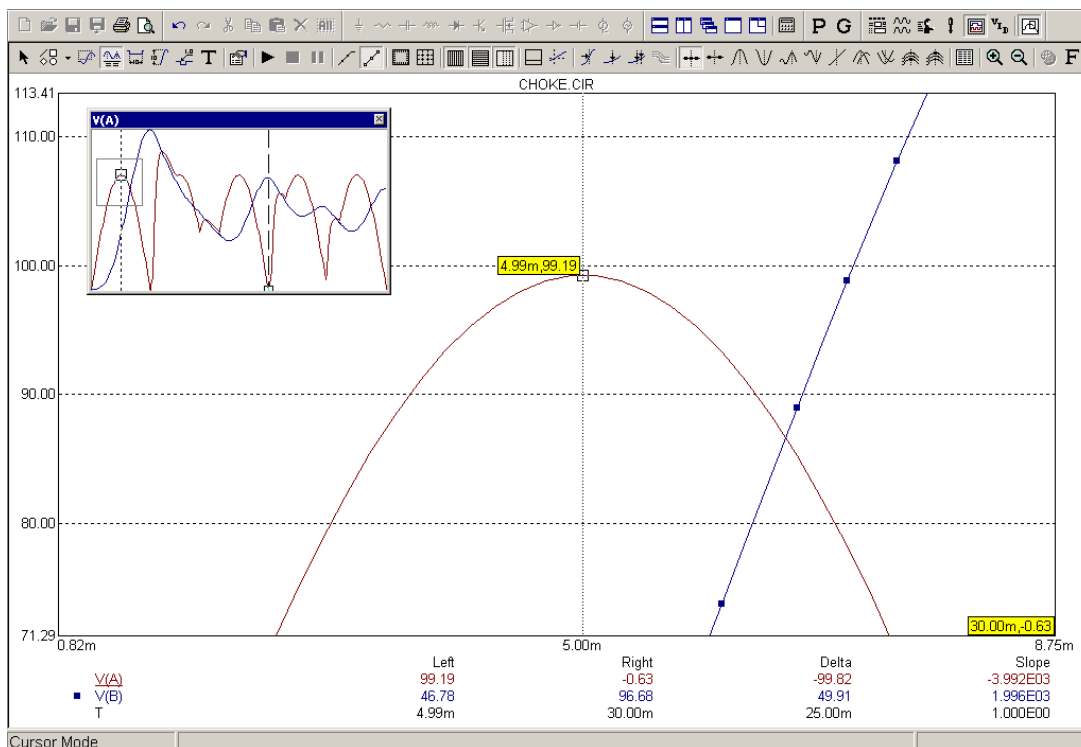

Complex trigonometric functions

All trigonometric and hyperbolic expressions were modified to accept and return complex arguments. New trigonometric functions included cot, sec, csc, acot, asec, and acsc. New hyperbolic functions included coth, sech, csch, acoth, asech, and acsch.

Complex conditional functions

The MIN, MAX, and LIMIT functions acquired complex arguments.

Expressions for histograms and performance plots

In earlier versions of Micro-Cap, only individual performance functions were allowed. MC7 added individual performance function expressions as well. For example, expressions like Rise_Time(...) + Fall_Time(...) were allowed.

Attribute search and replace

A search and replace command was added to allow easy mass editing of model attributes.

PADS PCB output

The ability to write netlist files for interfacing to the PADS PCB program was added.

Energy variables

Stored, dissipated, and generated energy variables were added. Their format is similar to their power counterparts. EST is the total stored energy. EDT is the total dissipated energy. EGT is the total energy generated. Similar terms are available for individual parts. For example, ED(Q1) is the energy dissipated in Q1, and ES(Q1) is the energy stored in Q1.

New MOSFET noise terms

The standard PSpice noise terms, NLEV and GDSNOI, are now included in all MOSFET and BSIM models.



Variable K Transformer Model

Ever wanted to vary the K value in a transformer but couldn't? Well you can if you use the equivalent circuit below. This is an equivalent circuit for the transformer primitive.

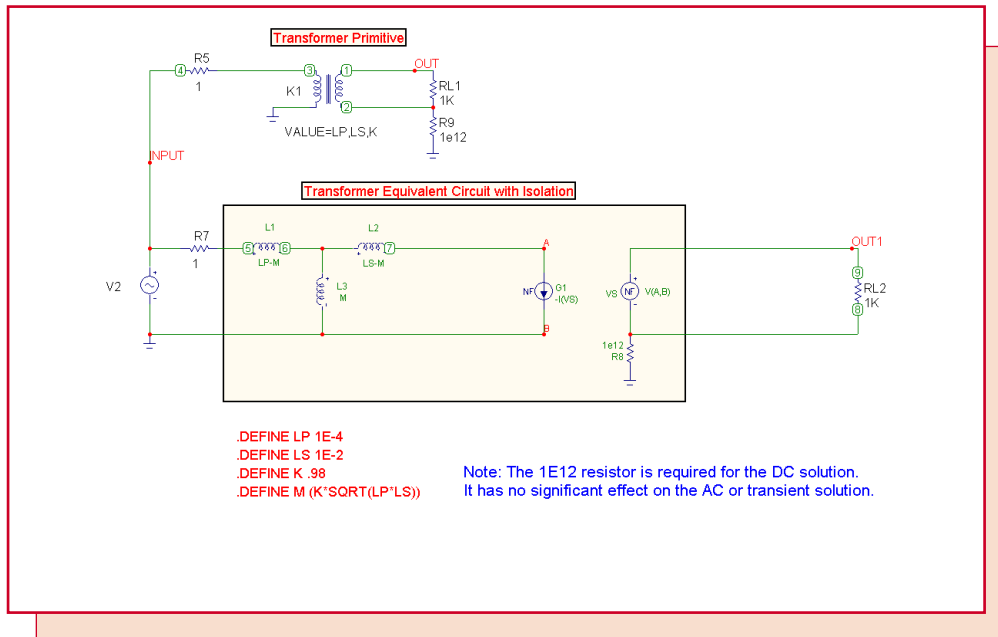

Fig. 1- Transformer equivalent circuit

The general transformer equations are as follows:

Basic transformer equations:

$$(Z1 + S*LP)*I1 + S*M*I2 = V1$$

$$S*M*I1 + (Z2 + S*LS)*I2 = 0$$

Definition of Terms

- I1 is the current flowing the primary
- I2 is the current flowing in the secondary
- V1 is the primary input voltage
- Z1 is any impedance in series with the primary
- Z2 is any impedance in series with the secondary
- LP is the primary inductance
- LS is the secondary inductance
- M is the mutual inductance between LP and LS

These transformer equations are implemented in the circuit above. The utility of this equivalent circuit is that its part values can be expressions and thus varied during a run, whereas in current Micro-Cap implementations (through Micro-Cap 7.0), the transformer parameters (L1, L2, and K) cannot be time-varying expressions.

Here is the transient analysis of the circuit above.

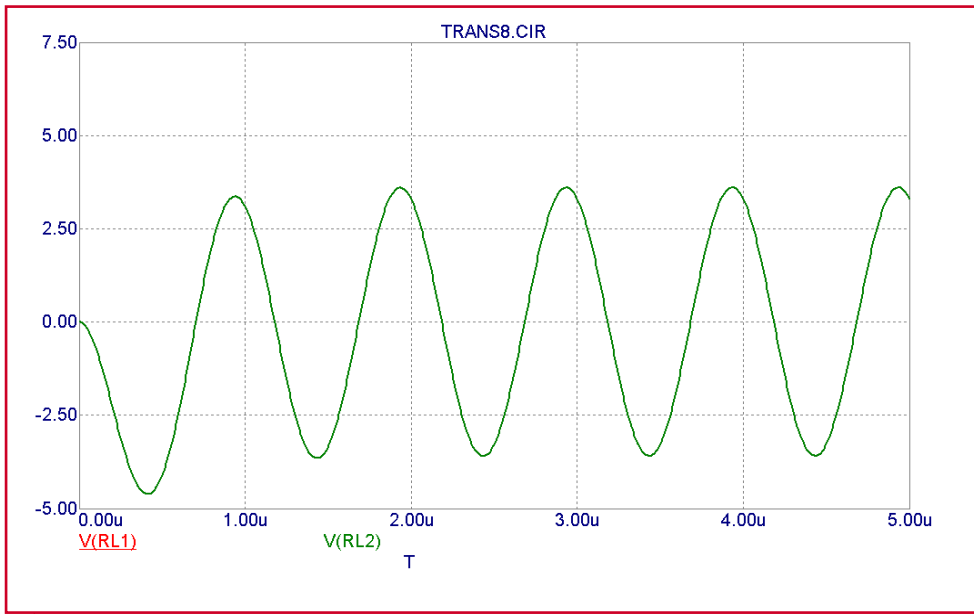

Fig. 2- Transient analysis of transformer primitive and equivalent circuit are the same

The transient analysis shown in Figure 1 and the AC analysis shown in Figure 2 show identical plots for both the primitive and the equivalent circuit model outputs, demonstrating the electrical equivalence of the transformer equivalent circuit.

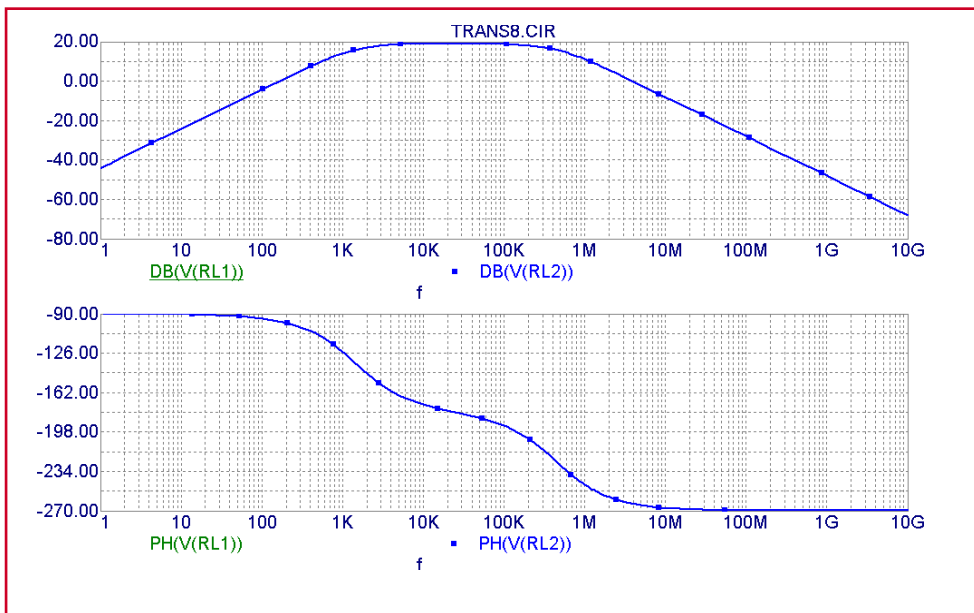

Fig. 3- AC analysis of transformer primitive and equivalent circuit are the same

With this equivalent circuit in mind we'll now modify the circuit by changing the K value from a constant to a variable. This is done by simply changing its .define statement as follows:

Old: `.DEFINE K .98`

New: `.DEFINE K 1.0*(10U-T)/10U`

The new expression for K causes it to vary linearly over time.

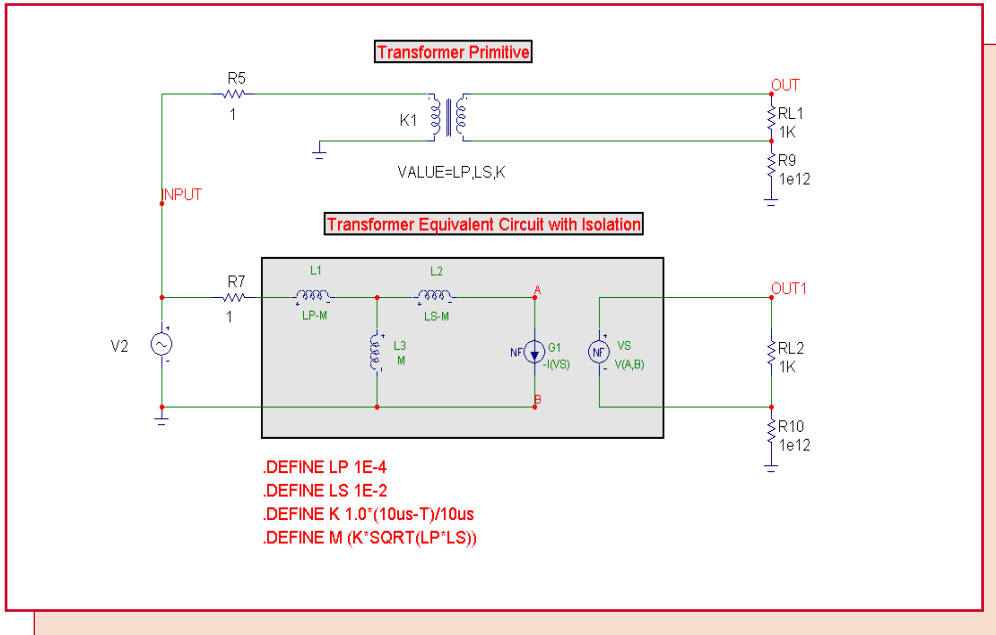

Fig. 4- Transformer model with a time-varying K value

Here is what the transient analysis for 5us looks like.

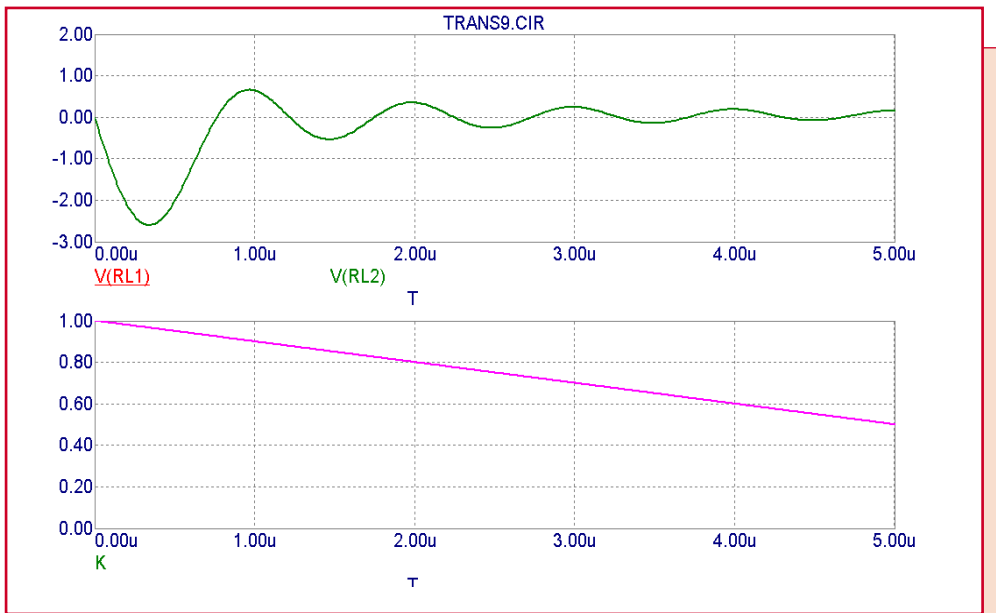

Fig. 5- Transient run showing effect with a time-varying K value

Having gone through the exercise of how to do a transformer variable K expression, we thought it would be a good idea to simply add it to MC7. So we did. Micro-Cap 7 Version 7.02 or later has this capability built in. Prior versions would only allow a constant K value. Now, you can simply write an expression for the transformer K value. A typical transformer with an expression looks like this:

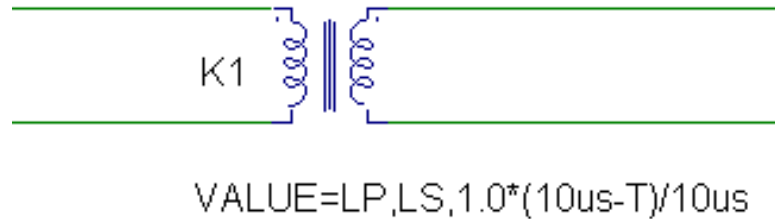

Fig. 6- Transformer primitive with a time-varying K value

If you have Micro-Cap 7 Version 7.0 or 7.01 you can update by downloading the MC7.ZIP file from our web site at www.spectrum-soft.com

Plotting Filter Step and Impulse Response

Some users have asked how to get a plot of the step and impulse response for a filter designed by Micro-Cap. Well it is very easy to do. Both of these plots require a transient analysis of the filter circuit. In the case of the step response we need the response to a unit voltage step at the input. In the case of the impulse response, we need the response of the circuit to an impulse waveform at the input. Both of these responses can readily be obtained by placing a Pulse source at the input and then editing its parameters to produce either a step or an impulse waveform.

A step waveform is simple. The required parameters are as follows:

```
.MODEL STEP PUL (VONE=1 P1=1m P2=1.001m P3=100m P4=100.001m P5=1)
```

These parameters are setup for a bandpass filter with a center frequency of 1Khz. For a slower filter you might want to increase the pulse duration. The main point is you need a 1 volt step occurring sometime after T=0 and lasting long enough so the step waveform and the response is easy to see.

An impulse waveform is also easy. Its parameters look like this:

```
.MODEL IMPULSE PUL (VONE=1E9 P1=0 P2=.001N P3=1N P4=1.001N P5=1)
```

The important consideration here is that the integral of the pulse have a value of about 1 (1E9 amplitude times 1E-9 width) and that its rise and fall times (.001n) be short in comparison to the pulse width (1n).

When the Active Filter or Passive Filter program creates a filter, it automatically places a Pulse source at the input and gives it the Model name Step, so all we need to do is to edit the model parameters to create the step we want.

As an illustration, select the Active Filters item from the Design menu. Click on the Default button. Then select the Bandpass and Chebyshev options. Select the Circuit option on the Options panel / Circuit group. Finally click on the OK button and Micro-Cap will create the schematic for a Chebyshev 1Khz bandpass filter. It looks like this:

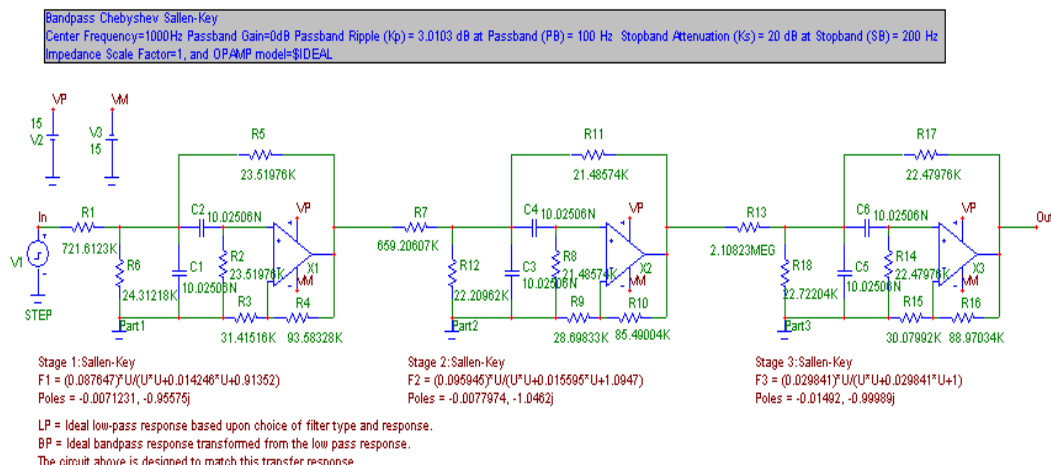

Double click on the Pulse source and edit its parameters to the Step parameters shown above.

Select Transient analysis from the Run menu and when the Analysis Limits dialog box comes up change the analysis limits to these:

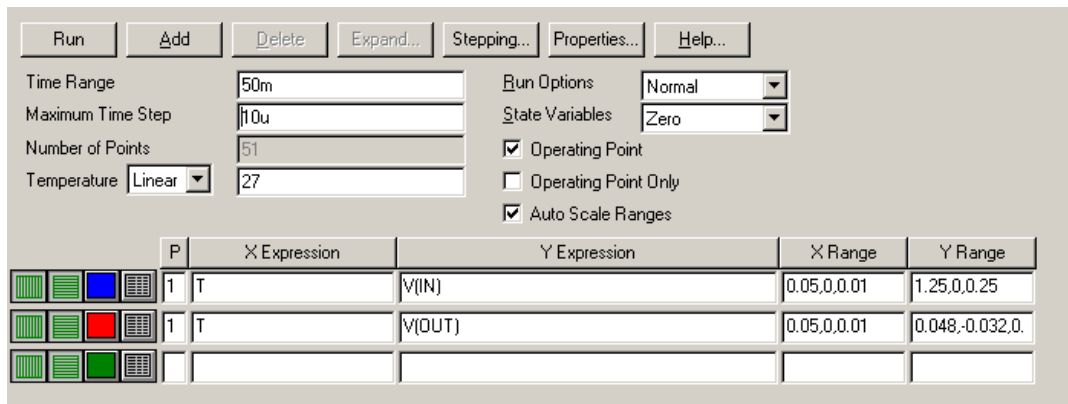

Make sure that the Same Y Scales option on the Scope menu is not checked. Press F2 and the step response is plotted as follows:

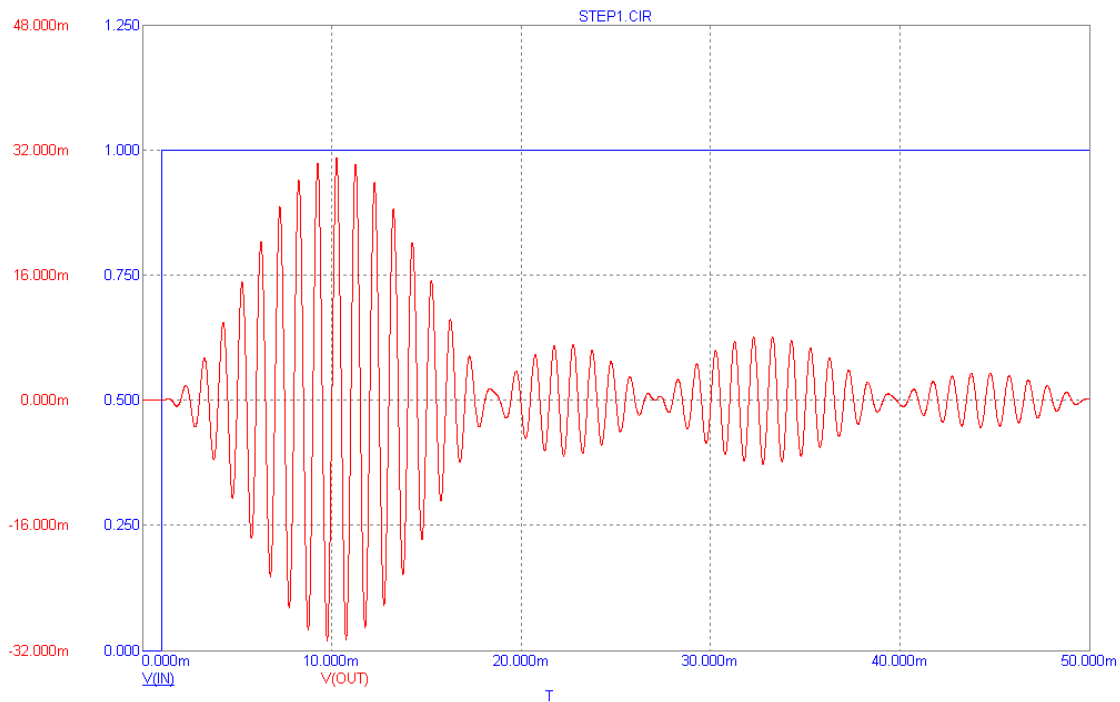

The plot shows the input 1 volt step starting at 1ms, and the filter output waveform. The result is a classic step response for a third-order Chebyshev bandpass filter.

To produce an impulse response we need only modify the Pulse source.

Press F3 to exit transient analysis and return to the schematic editor. Double click on the Pulse source and change the Model name to Impulse. Edit the parameters to those shown above for the impulse response.

Select Transient analysis from the Run menu and when the Analysis Limits dialog box comes up simply press F2 to start the run. The analysis parameters are the same as the Step case.

When the run is finished the plot should look like this:

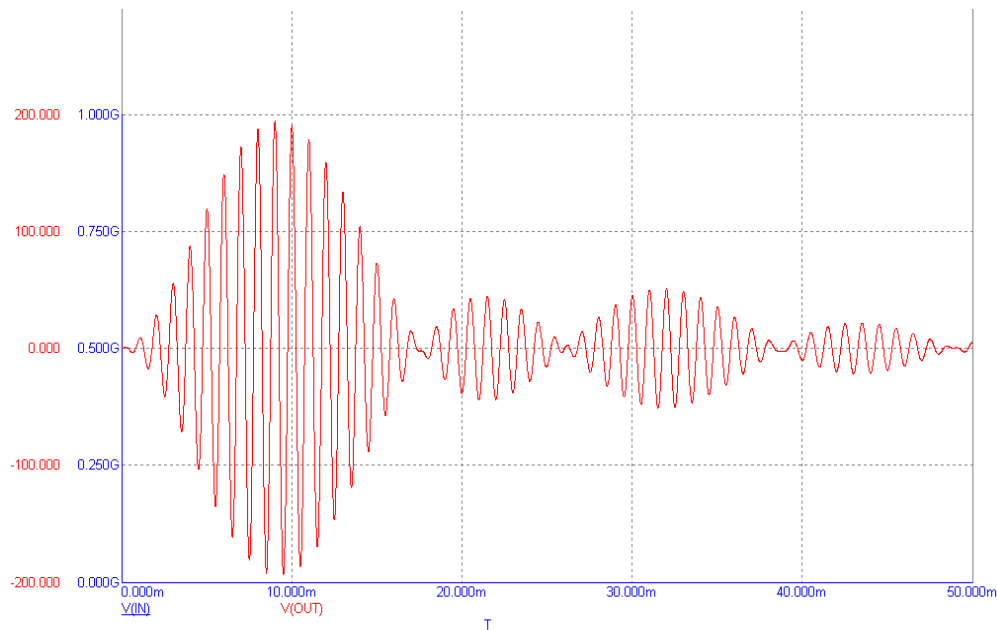

The display shows the impulse waveform and the response waveform from the filter output. The impulse waveform is so narrow it appears to be a vertical spike, but it actually is 1E9 high and 1ns wide. The output response shows a resonant oscillation whose frequency is at 1Khz, which is also the BP center frequency.

In summary all you need to do to the standard Active Filter or Passive Filter circuit file is:

- 1) Edit the Pulse parameters to produce either a step or an impulse.
- 2) Edit the transient analysis parameters so that:
 - A) The Time Range is between $10/FC$ and $50/FC$, where FC is the center or cutoff frequency of the filter. You may need to increase or decrease this value to see more or less of the response.
 - B) Maximum Time Step is about $.001 * \text{Time Range}$ chosen in step A. This simply assures a smooth plot.
 - C) You are plotting V(IN) and V(OUT).
 - D) Auto Scale Ranges option is enabled.
 - E) The Same Y Scales option on the Scope menu is disabled.

For further illustration, here are the step and impulse responses of a 1Khz Chebyshev low pass filter with default settings. Note that here we have used a Time Range of $20 \cdot F_c$ ($20\text{msec} = 20 / 1\text{Khz}$) for better waveform clarity.

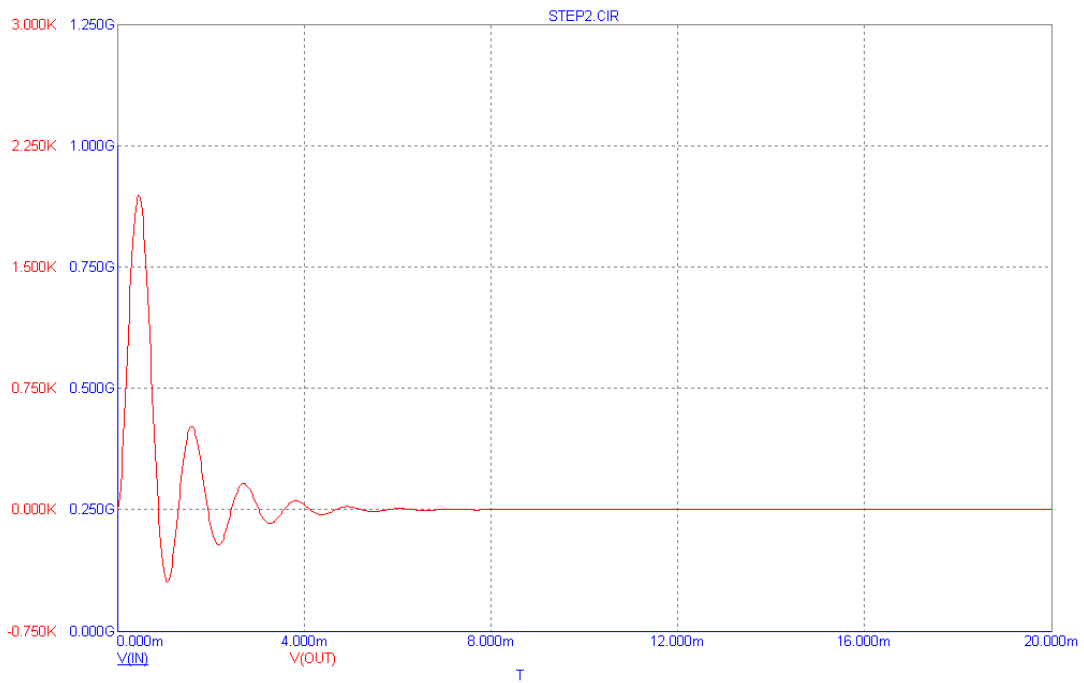
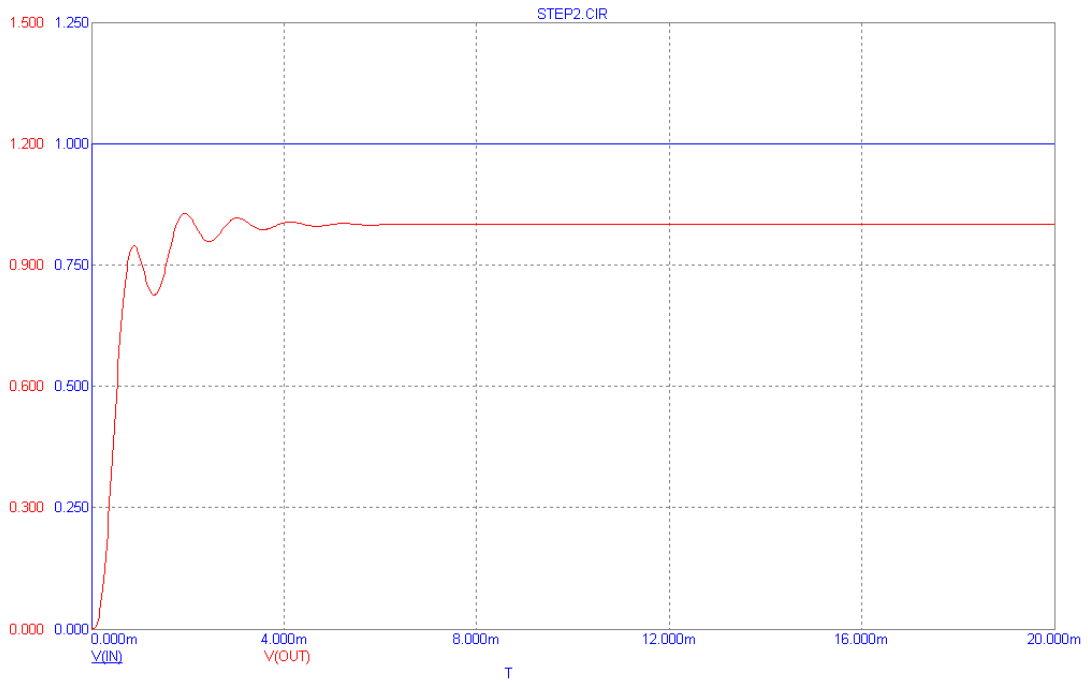

Product Sheet

Latest Version numbers

Micro-Cap 7 Version 7.02
Micro-Cap 6 Version 6.29
Micro-Cap V Version 2.1.2

Spectrum's numbers

Sales (408) 738-4387
Technical Support (408) 738-4389
FAX (408) 738-4702
Email sales sales@spectrum-soft.com
Email support support@spectrum-soft.com
Web Site <http://www.spectrum-soft.com>