

Universal Radio Communication Tester R&S®CMU 200

Production test software for GSM reference designs

With market cycles becoming shorter and the variety of mobile phones steadily increasing, product life cycles have to be optimized at all stages. A critical hurdle is the handover of a product from development to production. To ensure smooth startup of large-scale production after type approval testing, ready-made solutions are required, and a test program has to be created while still in the development phase. Using the R&S®CMU-TSR 10 start-and-go package in conjunction with reference designs puts convenient ready-made solutions at your fingertips.

The mobile radio market is rapidly changing

In the past, mobile phones stayed on the market for one or two years. Today, market cycles are often no more than just a few months, depending on customer acceptance. Manufacturers must offer a great variety of designs in order to satisfy specific customer groups. The schedule from start of development to series production must be strictly observed to ensure market success.

Design, development, type approval testing, pilot production, mass production and service are closely interrelated and must be optimally planned. To simplify hardware and software development, the manufacturers of chip sets for mobile phones supply their customers with reference designs, thus providing comprehensive support. Reference designs contain a functional evaluation board, loadable instrument firmware with a protocol stack, as well as software modules. They allow design and development time to be cut by several months, so that mobile phone manufacturers can concentrate on device functions (design, operation, data interfaces, etc). Development costs are also reduced.

Reference designs simplify development

Evaluation boards of the latest generation are based on an LSI chip set that usually contains only five chips:

- ◆ Baseband chip
- ◆ Power management and codec chip

- ◆ RF transceiver
- ◆ RF power amplifier
- ◆ Flash memory

The boards normally have the dimensions of the target layout (approx. 35 mm × 60 mm). GSM quadband modules, for example, support the 850 MHz and 1900 MHz bands for the USA and 900 MHz and 1800 MHz for Europe and Asia.

Along with the reference design, chip set manufacturers supply circuit diagrams, parts lists and the layout drawing, which allows the critical RF section to be transferred unchanged to the target layout. An expandable GSM/GPRS protocol stack is also available and can be integrated as the core module into the software of the new mobile phone.

R&S®CMU-TSR 10 start-and-go package

The R&S®CMU-TSR 10 start-and-go package consists of a cable set and an installation CD. By using a simple test setup that includes the start-and-go package, the Universal Radio Communication Tester R&S®CMU 200 and an evaluation board (FIG 1), you are ready to perform a complete calibration test sequence, typically in the following order:

- ◆ Initialize the R&S®CMU 200
- ◆ Switch the evaluation board to test mode
- ◆ Calibrate the DC offset
- ◆ Calibrate the AFC
- ◆ Calibrate the power control levels of the RX and TX sections
- ◆ Calibrate the RX and TX sections over the channels

- ◆ Store the calibration results on the evaluation board
- ◆ Set up the connection
- ◆ Check the RF calibration including signaling
- ◆ Measure the bit error ratio (BER), RF power and spectrum

The limit values for the various measurements as well as the setting parameters for the R&S®CMU200 are stored in ASCII files and can easily be modified to generate simulation sequences. Results and associated limit values are recorded in a straightforward report file and used in subsequent analysis.

The crucial step: calibration of the RF section

To perform stable and fast adjustment of a mobile phone's RF section, you require detailed knowledge about the RF transceiver chip. Using the calibration test sequence included in the R&S®CMU-TSR 10 start-and-go package, you can perform an automatic test of your new hardware design to check whether the RF section is functioning properly. Results will be stored for each test sequence and are available for subsequent statistical evaluation. If you need any additional test steps, you can add them quickly and conveniently. The reference design manufacturer and Rohde & Schwarz collaborate closely to make sure that the software libraries work well together (FIG 2).

With the evaluation board, the RF test program for pilot and / or series production can be generated while still in the development phase. The Generic Test Software Library R&S®GTSL from Rohde & Schwarz, which is included in the start-and-go package, provides an optimized solution for the time-critical RF transceiver adjustment: For the transmitter section, individual power control levels (PCL) are measured and intermedi-

ate values determined by way of interpolation. At a fixed power control level, the frequency response over the channels is determined also by way of interpolation. Receiver adjustment is performed using the same steps. By applying this solution, you can ensure that scheduled test times will be adhered to in subsequent series production.

Designed to work together

The R&S®GTSL software library contains ready-to-run setting and measurement functions for all common mobile radio standards; the functions are tailored for use with the R&S®CMU200 (FIG 3). Tests cover all mobile phone function blocks and include, for example, audio

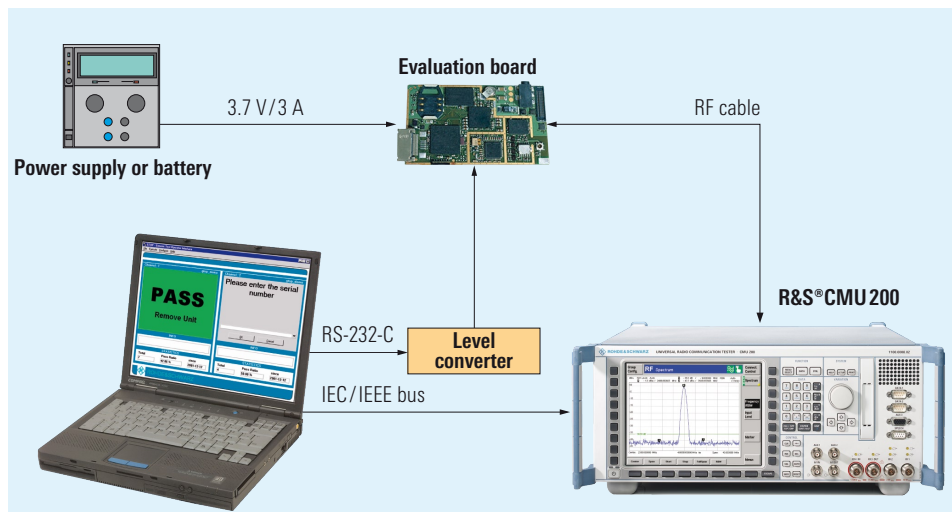

FIG 1 The R&S®CMU-TSR 10 start-and-go package is ready to run with just a few components.

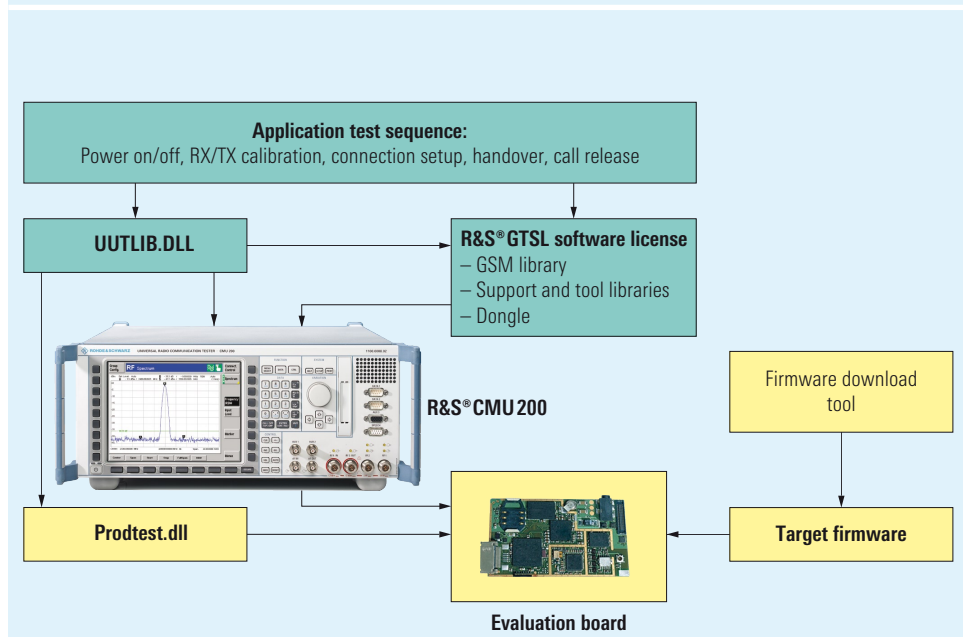

FIG 2 Joint development of software tools for reference designs (yellow: components from chip set manufacturer; green: components from Rohde & Schwarz).

- ▶ and acoustic tests as well as RF tests and signaling tests. Functions are available in the form of dynamic link libraries (DLL) that you can adapt via menus as required. Moreover, you can modify limit values and setting parameters quickly and conveniently using a standard text editor.

R&S®GTSL offers you numerous advantages:

- ◆ Simplified programming of the R&S®CMU200
- ◆ Data storage and report generation already available in the TestStand™ sequencer from National Instruments
- ◆ Examples of complete test sequences
- ◆ Support of all common mobile radio standards such as GSM, GPRS, TDMA (IS-136), AMPS, cdmaOne, CDMA2000®, WCDMA
- ◆ Simple user interface for production environments

- ◆ Example source code for expansions of R&S®GTSL
- ◆ Easy integration of additional system components

Summary

When used in conjunction with reference designs, the R&S®CMU-TSR 10 start-and-go package helps mobile phone manufacturers reduce development time and limit the risks involved in new developments. Rohde & Schwarz also offers complete turnkey solutions for use in mobile phone production. These solutions are based on the Test Platform R&S®TS 7180 [*], which consists of a test rack with the R&S®CMU200, the Shielded RF Test Fixture R&S®TS 7110 and the R&S®GTSL system software.

Erwin Böhler

**More information on
Rohde & Schwarz test systems at
www.testsystems.rohde-schwarz.com**

REFERENCES

- [*] Test Platform for Mobile Phone Production R&S®TS 7180: Ready for mass production, incoming goods inspection and service. News from Rohde & Schwarz (2002) No. 176, pp 10–13

FIG 3 Architecture of R&S®GTSL software library.

