

Version
06.00May
2004

Universal Radio Communication Tester R&S® CMU200

THE multiprotocol tester for current and future mobile radio networks

- ◆ Extremely high-speed testing
- ◆ Highly accurate measurements
- ◆ Modular future-proof design
- ◆ Comprehensive spectrum analyzer
- ◆ Fast switching between networks



ROHDE & SCHWARZ

Testing the 3rd generation

For more than 70 years, Rohde&Schwarz has always been at the forefront of mobile radio technology. We continue this tradition of RF test and measurement with the Universal Radio Communication Tester R&S® CMU 200. The R&S® CMU 200 is a third-generation-platform design that offers true scalable multimode functionality.

The R&S® CMU 200 reflects the many years of expertise Rohde&Schwarz has gained in the world of mobile radio. In recent years, the company has helped to launch overwhelmingly successful mobile radio systems.

Rohde&Schwarz is a preferred supplier to many of the leading mobile equipment manufacturers and is the market leader for mobile radio test sets.

The R&S® CMU 200 is part of a complete range of mobile radio test equipment, encompassing everything from conformance test systems to system simulators, turnkey functional board test / final test systems and simple sales-counter Go/NoGo testers.

The base unit with its standard-independent module test provides many general-purpose measurement facilities for the development of all kinds of standards within its wide and continuous frequency range. If extended by the appropriate options, the R&S® CMU 200 offers the hardware and software necessary to handle your 3G, 2.5G and previous-generation testing applications, including analog.

Low cost of ownership

Selecting the R&S® CMU 200 is a decision for the future and results in a total cost of ownership that is sure to be among the lowest due to the following factors:

- ◆ The completely modular design of hardware and software components eliminates unnecessary investments right from the start merely because a feature might be needed at some point in the future. You only pay for what you need
- ◆ If an expansion becomes necessary because your needs grow, the modularity of the R&S® CMU 200 concept will make this easy. Many expansions to the unit may be installed on site. You pay for them only when you need them.
- ◆ Maximum production output in a compact 4-rack-unit-high package with minimum power dissipation allows compact production space layout.
- ◆ With the intuitive R&S® CMU 200 user interface, even less experienced users do not require extensive training.
- ◆ A new remote interface syntax reflects the inherent modularity of this real multimode tester.

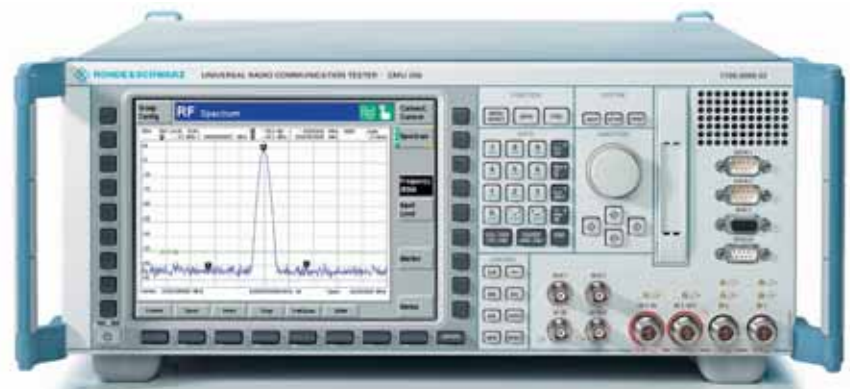

The R&S® CMU 200 targets a wide range of applications but is primarily optimized for the high accuracy and speed demanded in increasingly quality-conscious manufacturing processes. The picture shows the front panel for desktop use.

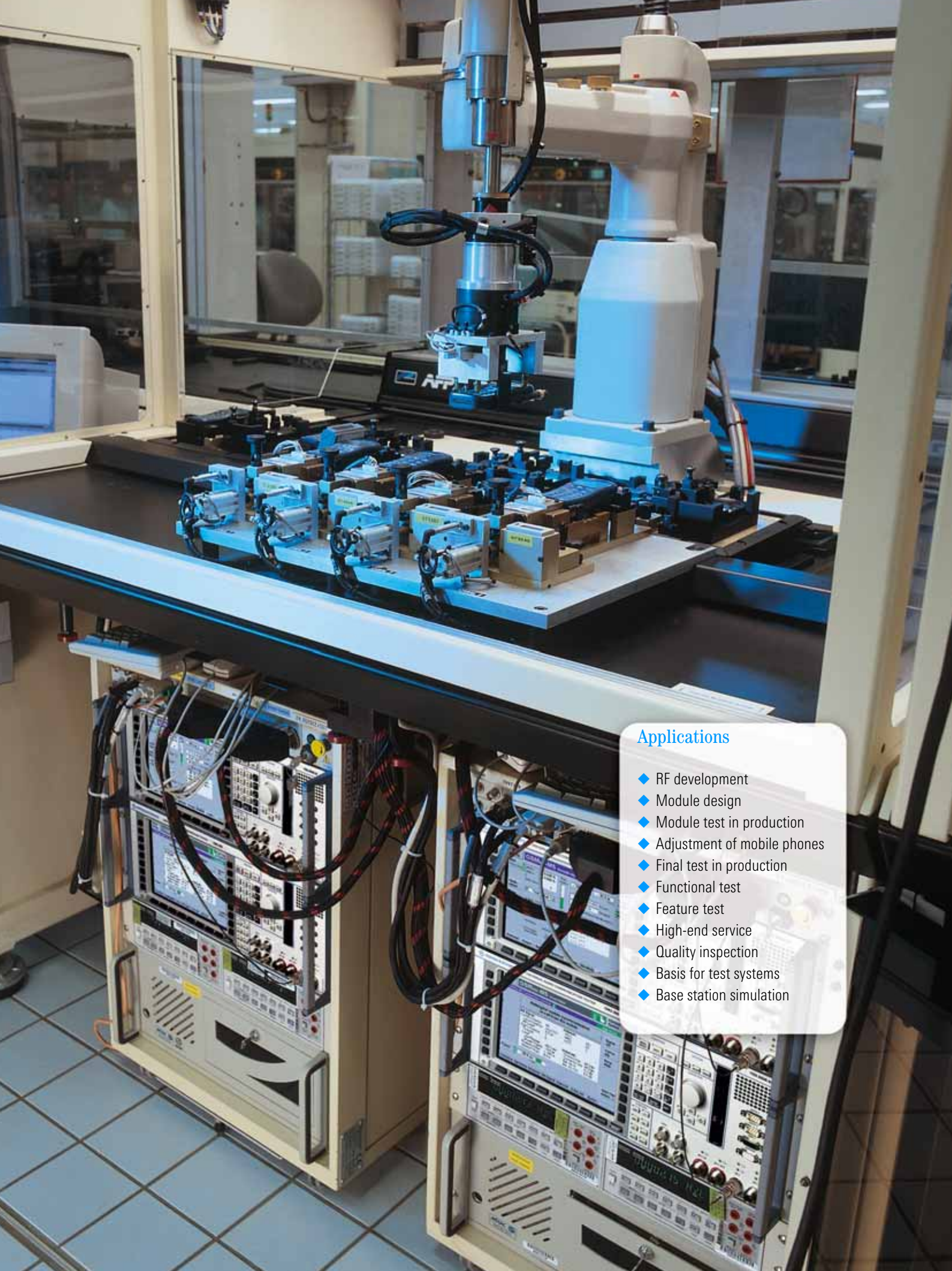

Applications

- ◆ RF development
- ◆ Module design
- ◆ Module test in production
- ◆ Adjustment of mobile phones
- ◆ Final test in production
- ◆ Functional test
- ◆ Feature test
- ◆ High-end service
- ◆ Quality inspection
- ◆ Basis for test systems
- ◆ Base station simulation

Usability

The R&S® CMU200 key strengths

The Radio Communication Tester R&S® CMU 200 brings premium cost effectiveness through a variety of features, with extremely fast measurement speed and very high accuracy being the two most important ones. In addition, the secondary remote addressing of the tester's modular architecture makes for intelligent and autonomous processing of complete measurement tasks and fast control program design.

Maximum accuracy

In a production environment the tester's high accuracy allows devices under test (DUTs) to be trimmed for maximum battery lifetime without compromising quality. In the lab, the R&S® CMU 200 enables the development engineer to partly replace conventional, dedicated premium-quality instruments and save desktop space at the same time. High-precision measurement correction over the entire frequency and dynamic range as well as compensation for temperature effects in realtime are critical factors for achieving the R&S® CMU 200's excellent accuracy.

The globally standardized Rohde&Schwarz calibration system can check the R&S® CMU 200's accuracy at a service center close to you or, in some cases, on your premises. A worldwide network of these standardized automatic calibration systems has been implemented in our service centers. Highly accurate and repeatable calibration can be performed wherever you are. Your local Rohde&Schwarz representative offers customized service contracts. For large-scale users of the R&S® CMU 200, a compact level verification system is available in addition.

Owing to the high resolution of the extremely bright high-contrast TFT display even the finest details can be displayed

Direct branching to all associated menus makes for a uniquely flat menu structure

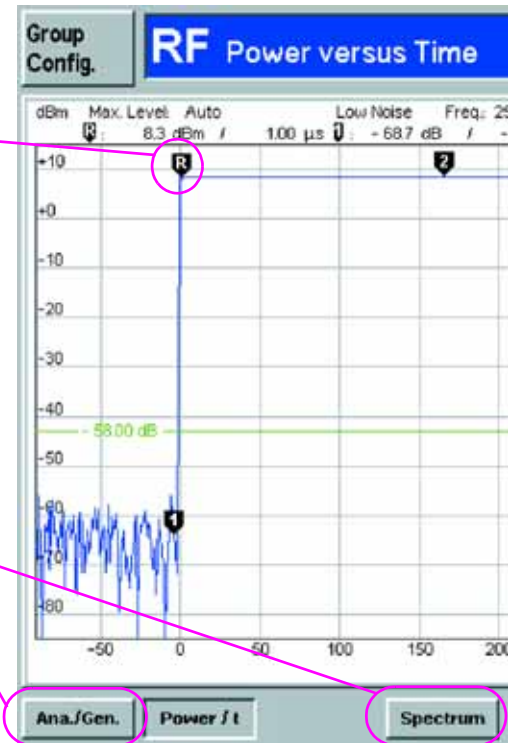

Top speed

The high processing speed is due to extensive use of ProbeDSP™ technology, parallel measurements and innovative remote command processing.

- ◆ ProbeDSP™ technology
The modular architecture relies on decentralized ProbeDSP™ processing coordinated by a powerful central processor. Like an oscilloscope probe, DSPs dedicated to a specific local data acquisition and evaluation workload help to keep subsystem performance at a maximum even if additional modules are fitted to the R&S® CMU 200 mainframe.
- ◆ Parallel measurements
Several RX and TX measurements can be performed in parallel. This is achieved by the fast response of the R&S® CMU 200's modular hardware as well as the high overall processing power of the instrument and the avoidance of bottlenecks by de-

icated operation of the ProbeDSP™ technology. Examples of parallel operation are measurements of BER and simultaneous phase/frequency error, error vector magnitude (EVM), magnitude error and audio, or the various spectrum measurements.

- ◆ Innovative remote processing
The novel secondary addressing mode can address similar functions of each of the R&S® CMU 200 subsystems (i.e. different mobile radio standards) in an almost identical way. Using this type of addressing, new remote test sequences can be programmed by a simple cut-and-paste operation followed by the editing of specific commands to adapt the control program to the new application. Secondary addressing is fully SCPI-compliant, which means that a subsystem address, for example WCDMA, can be replaced by a string denoting a different subsystem, i.e. another mobile radio standard.

As the R&S®CMU200 offers many of its measurements in signalling and non-signalling mode, this simple visual indication of the signalling state is provided as part of the status line

This symbol shows the instrument status, i.e. remote or manual operation

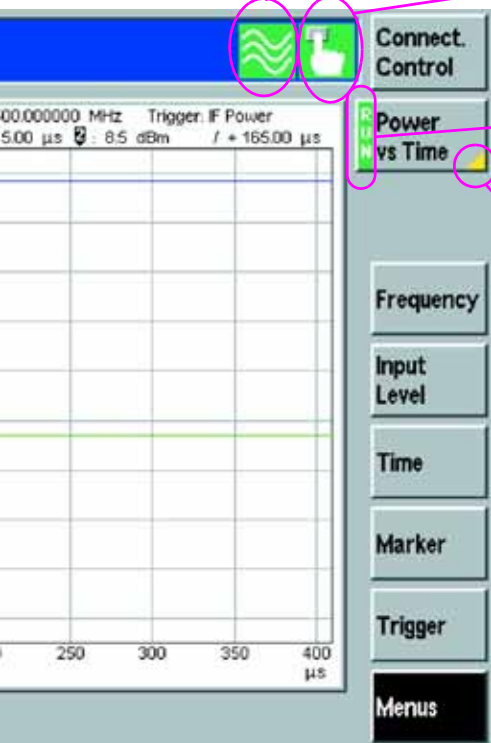

For increased speed, measurements not required can be switched off to free resources for the measurements you want to focus on

Measurements are configured by twice pressing the softkey marked with the yellow triangle

Key advantages of the R&S®CMU200

Speed

- ◆ Unrivalled speed of single measurements

Accuracy

- ◆ Incomparable accuracy
- ◆ Excellent result repeatability

Modularity

- ◆ Modular hardware and software concept provides easy expansion to further functionality

Reliability

- ◆ Extremely low power consumption and effective heat conduction result in unparalleled reliability

Future-proof

- ◆ Easy migration to emerging standards

Exceptional reliability

The R&S®CMU200 employs ultra-effective heat management between housing and individual components as well as between heat sinks and air flow. Together with the independent cooling cycles for different modules, this adds up to an optimized cooling system.

The base unit

The base unit without any options installed can be used for testing general parameters of 1st, 2nd or 3rd generation mobile phones. The R&S®CMU200 base unit is the ideal solution for tasks at the module level, i.e. at the early production stages of all cellular standards.

Integral parts of the R&S®CMU200 base unit are the RF generator and RF analyzer, which are complemented by a versatile, network-independent time domain menu

and a comprehensive spectrum analyzer. The illustration above shows a power versus time measurement as an example.

By combining graphical and numerical overview menus, the user can select the optimal view when the R&S®CMU200 is in manual mode.

The menu structure of the R&S®CMU200 is very flat and uses context-sensitive selection, entry and configuration pop-up menus.

Advanced operational ergonomics have been incorporated into a highly compact and lightweight, 4-rack-unit-high package.

Optimized solutions for your production test requirements

Rohde&Schwarz supports R&S®CMU200-based production test solutions through a comprehensive network of application engineering sites. The backbone of this network consists of the four system integration centers located in Asia, North America and Europe.

System integration services

Regional center project teams offer local system integration, service and support. A team of experts is ready to provide turn-key solutions, including test case programming. Custom-tailored project solutions and site process optimization are major aspects of our services.

Time to market

The key to commercial success is the time required to get a new product to market in large numbers. The crucial point is the fast transition from product development to mass production. The Cellular Phone Production Test Platform R&S®TS7180 featuring the R&S®CMU200 meets this challenge.

R&S®TS7180 description in brief

The R&S®TS7180 test platform can test two mobile phones simultaneously. It essentially consists of two Radio Communication Testers R&S®CMU200, two Dual-Channel Analyzers/Power Supplies R&S®NGM02, two Shielded RF Test Fixtures R&S®TS7110 for holding the DUT, and an industrial PC. The modular RF Test Fixture R&S®TS7110 can be expanded from a bed-of-nails PCB test fixture up to a fully configured test fixture for final testing, including an antenna for RF tests, a loudspeaker and microphone for acoustic tests, a camera for LC display tests, a

test pattern for the camera of the DUT, and pneumatic fingers for keypad tests.

The Shielded RF Test Fixture R&S®TS7110 for mobile phones can be adjusted by means of swap kits to accommodate several types of DUTs. It can be used for the following tests:

- ◆ RF (antenna)
- ◆ Audio
- ◆ LC display
- ◆ DUT camera and keypad and other DUT interfaces



The Shielded RF Test Fixture R&S®TS7110.

The R&S®TS7180 supports common mobile radio standards such as GSM, GPRS, cdma2000 and WCDMA by means of ready-to-run test sequences supplied with the platform. The test sequences can be extended and modified by means of a flexible sequence editor.

The software can thus simultaneously use the resources of the parallel equipment to maximize speed in highly automated production. We can offer optimally configured test systems customized to your production environment.

Test executive and generic test software library features

The parallel hardware is fully supported by TestStand, the industry-wide test executive from National Instruments. A user-friendly connection to the available device drivers has been created to provide faster use of the test executive. This connection is established by the generic test software library (GTSL). At the same time, the toolkit concept provides ready-to-run test cases, which can be customized by the user as required.

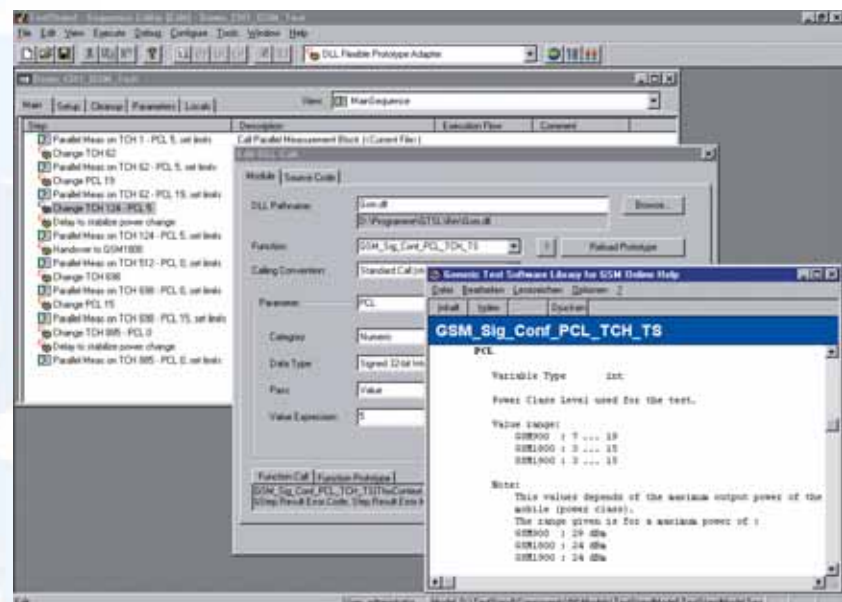

Sequence editor.

R&S® TS7180/7110 features in brief

- ◆ High throughput by parallel testing of mobile phones
- ◆ One system for functional board test, phone calibration and final test
- ◆ One system for all major mobile phone standards
- ◆ Easy expansion to 3rd generation technologies
- ◆ Ready-to-run Rohde & Schwarz GTSL test library for immediate use or customization
- ◆ Modular and versatile hardware/software platform
- ◆ Reduced costs due to generic concept
- ◆ Swap kit

R&S® TS7180:
example of a
2-channel system with one
R&S® TS7110
fixture.



For detailed information, see separate data sheets:

R&S® TS7110 (PD 0757.7723)

R&S® TS7180 (PD 0757.7469)

Software concept in brief

- ◆ Software platform based on LabWindows/CVI and TestStand from National Instruments
- ◆ GTSL includes ready-to-run test cases for the standards supported by the R&S® CMU200
- ◆ Functional test sequences for RF test, calibration, signalling test, audio and acoustic test of mobile phones are supported
- ◆ Transparent and open library can be expanded by the user
- ◆ Operator interface (GTOP) and test cases can be easily customized
- ◆ Parallel test of multiple mobile phones is fully supported
- ◆ GTSL supports multithreading and instrument sharing if needed
- ◆ Test development time is reduced by as much as 80 %

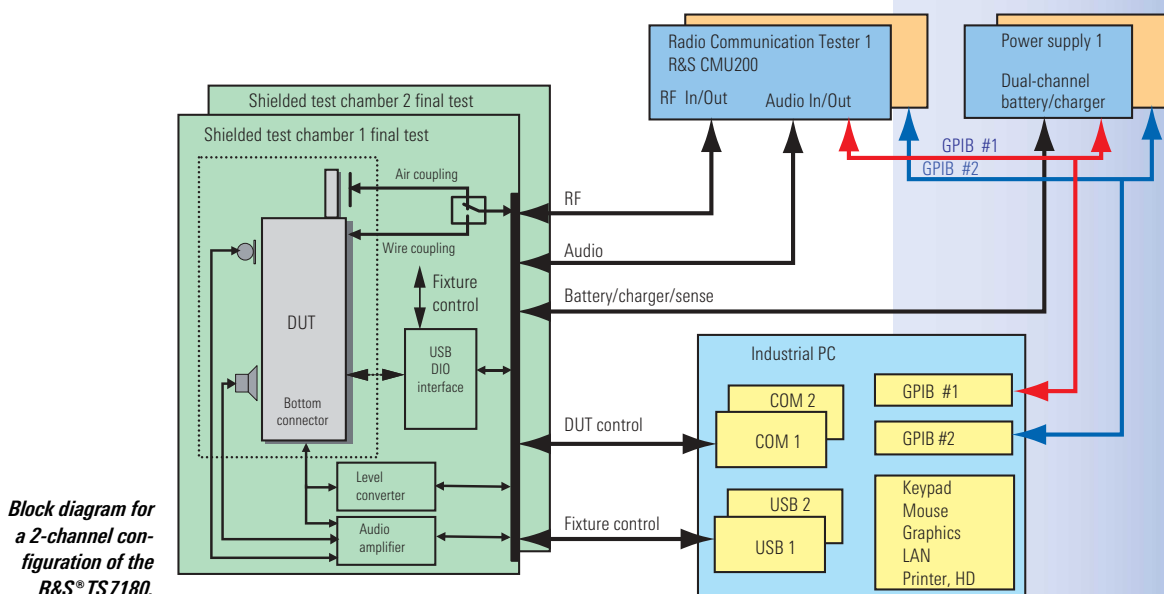

Block diagram for a 2-channel configuration of the R&S® TS7180.

Ready for today's networks ...

GSM today

Since its introduction in the early nineties, the GSM system has won acceptance and undergone an evolution that no one could have foreseen.

Currently, the following GSM systems are deployed in support of numerous applications worldwide:

- ◆ GSM400
- ◆ GSM850
- ◆ GSM900 including
 - P-GSM (primary GSM)
 - E-GSM (extended GSM)
 - R-GSM (railway GSM)
- ◆ GSM1800 (DCS)
- ◆ GSM1900 (PCS)

Whether the application is in production, service or development, the flexible concept of the R&S®CMU200 can handle practically all requirements: from basic RF signal generation, frequency, power and spectrum analyzer measurements for the alignment of modules in production or development, to full GSM-specific signalling in any of the above-mentioned bands, as well as module tests on frequencies anywhere in the range from 10 MHz to 2.7 GHz.

Signalling mode

The R&S®CMU200 simulates a GSM base station RF interface, providing the signalling flexibility necessary to test the performance of a mobile phone under the influence of different signalling parameters. These parameters are normally set by the network operator but can be reproduced by the R&S®CMU200 for test purposes. The instrument supports the latest fast location update and direct paging features.

Reduced signalling synchronized mode

The R&S®CMU200 provides the same functionality as in the signalling mode, but discards any signalling response from the mobile phone connected. This mode of operation enables testing of modules that only have layer 1 capabilities as well as very fast RF testing in production environments. It can also skip the location update procedure in order to save time.

Non-signalling mode

This mode is used to generate a signal with GSM-specific midambles and modulation in the entire frequency range from 10 MHz to 2.7 GHz. The analyzer offers the same flexibility for GSM-specific transmitter measurements such as

- ◆ Modulation analysis
- ◆ Average and peak burst power
- ◆ Power versus time, power versus slot, power versus frame
- ◆ Spectrum due to switching/modulation

GSM development

As a tool for GSM development engineers, the R&S®CMU200 is an unsurpassed solution. The RF interface provides four input and output connectors offering a wide range of signal levels for the generation and analysis of RF signals. Input-only connectors, as well as combined input/output connectors, can analyze mobile phones or modules with a sensitivity down to 0–80 dBm and up to +47 dBm for the power meter. RF signals can be generated with levels from 0–130 dBm up to

+13 dBm, depending on the selected connector.

All measurement tolerances are set by default according to the 3GPP TS 51.010 and 3GPP TS 45.005 recommendations but may be altered to suit individual needs.

Production of mobile phones

Production is a process that calls for cost effectiveness. The R&S®CMU200 concept is optimized for IEC/IEEE bus speed, measurement accuracy and reproducibility as well as cost of ownership. Owing to multitasking capability and parallel measurements, previously unobtainable test times can be achieved.

The flexible R&S®CMU200 hardware concept allows the latest DSP technologies to be used in measurements. The new R&S®CMU-U65 option, for example, considerably speeds up transmitter measurements (spectrum due to switching/modulation) to the extent that measurements virtually in realtime are possible.

The ability to process BER data and perform transmitter measurements at the same time allows phase/frequency error, power versus time and average power (PCL accuracy) to be measured during the time-consuming receiver test.

The accuracy and reproducibility ensure correct and stable measurement results and thus contribute to the quality and reliability of the end product.

GSM speech evolution – AMR

Maintaining good voice quality even under extremely poor transmission conditions is now possible with the innovative adaptive multi rate (AMR) voice coding

The GSM-specific non-signalling test provides generation and analysis of RF signals (GMSK or 8PSK modulated) for testing RX/TX modules or mobile phones in service mode.

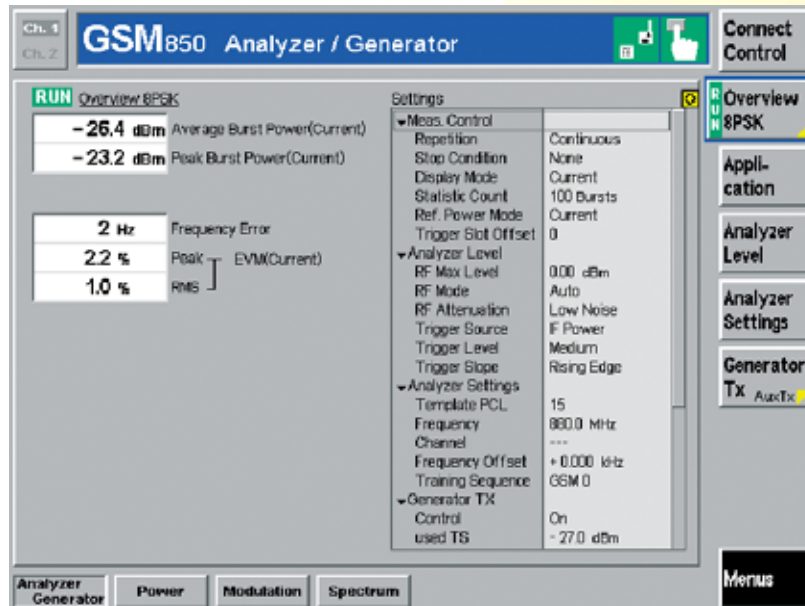

For an AMR full-rate or AMR half-rate link, a rate set of up to four combinations of voice and channel codings (codecs) can be selected from the eight full-rate and the six half-rate codecs. During a call, it is possible to switch between the rates of the rate set.

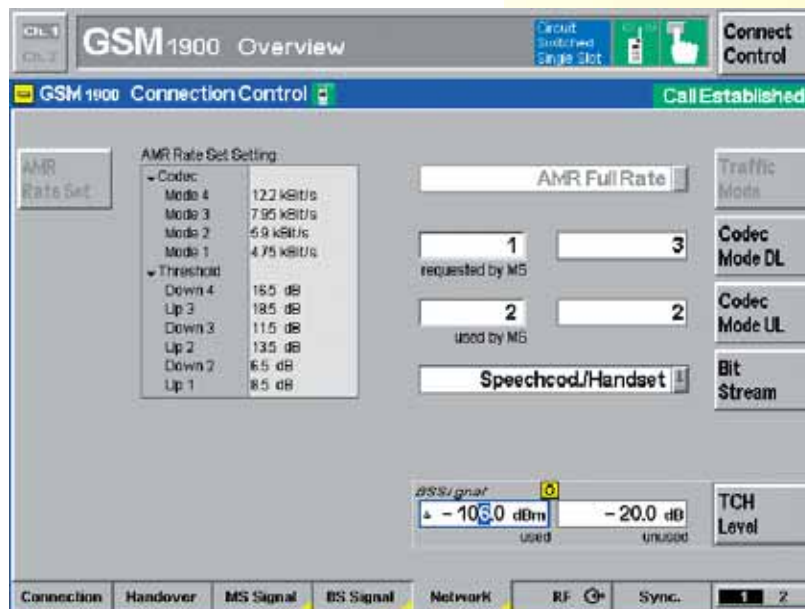

The overview menu provides fast comprehensive information on the mobile phone's RF performance; the hotkeys at the bottom of the screen provide immediate access to specific and detailed GSM measurements.

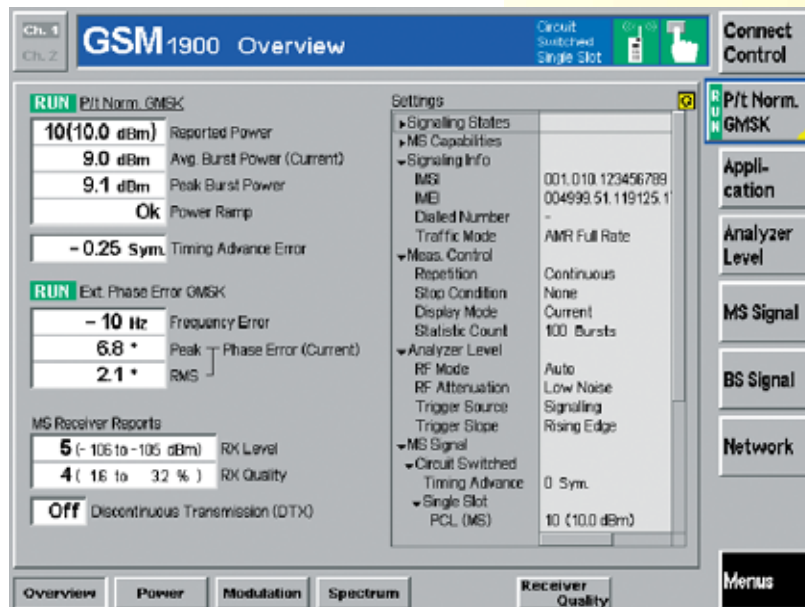

algorithm, which opens up new possibilities for GSM. The new algorithm allows voice quality to be gradually reduced in favour of improved error correction by dynamically adapting the data rate. Interruptions of voice transmission can thus be avoided by allowing a barely perceptible reduction in audio quality. The R&S®CMU200 provides all eight combinations of voice and channel coding (codecs) for full-rate and six combinations for half-rate transmission. For call setup, a set of four rates (codecs) is selected from the eight full-rate and the six half-rate codecs. Then additional test parameters (thresholds) are selected for the mobile phone. Dynamic switchover between the selected rates is effected by AMR inband signalling. In the uplink, the mobile phone informs the base station about the quality of the established link and proposes the optimal rate for the selected rate set to the base station.

GSM data evolution – 2.5G

The amount of data traffic in GSM networks is growing rapidly. Multislot applications such as HSCSD, GPRS and the innovative 8PSK modulation scheme EDGE are needed to support the increase in data traffic. The R&S®CMU200 platform is not only able to handle today's standards and systems but is also designed for the needs of tomorrow.

Multislot

In the future, mobile phones will be able to use several timeslots simultaneously for data transmission and reception to further increase the data rate. The simultaneous transmission and reception of several timeslots (multislot) is the main-technological challenge for circuit-switched and packet-switched applications. The following expansions of the GSM single-slot measurements enable maximum flexibility in development, and,

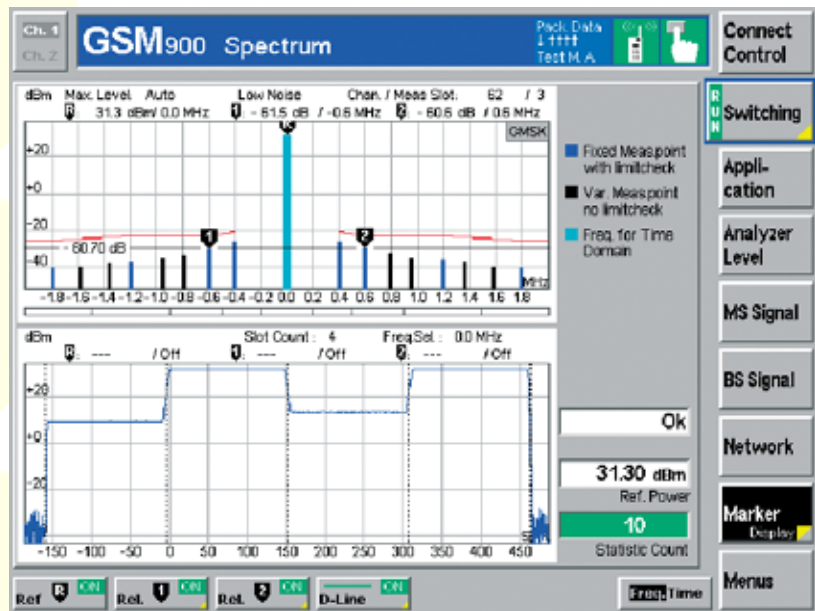

The newly designed spectrum application allows the simultaneous measurement of spectra due to switching and modulation. With the R&S®CMU-U65 option, this can be done virtually in realtime. Moreover, the user can select a frequency offset (spectral line) by means of a marker and display it in the time domain. Transient characteristics in spectrum-due-to-switching measurements can thus be shown as a function of time.

with reduced measurement times, maximum throughput in production.

- ◆ Individual levels for all timeslots used in the downlink (DL). The R&S®CMU generates up to eight timeslots per frame in the downlink; each timeslot can be assigned a separate level. The excellent level stability of the R&S®CMU200 generator is not impaired by multislot transmission using different levels, and allows highly accurate receiver sensitivity measurements (BER/BLER).
- ◆ Transmitter and receiver measurements are possible on every timeslot used. The new multislot concept allows independent measurements on any timeslot (TS 0 to 7) and thus covers the current and future multislot combinations without restrictions.
- ◆ The R&S®CMU200 combines high flexibility with great operating convenience. Based on the multislot capability information from the mobile phone, the R&S®CMU200 selects the maximum possible number of timeslots for a specific application

and, when changing between transmitter and receiver tests, automatically adapts the timeslot allocation.

- ◆ Power-versus-time measurement (graphical display) for up to four timeslots in the uplink (UL). The templates of this application are evaluated independently for each timeslot – in line with standards and according to recommendations. Both GSM- and 8PSK-modulated signals are recognized, and the templates of the relevant timeslot, depending on the modulation scheme used, are set in realtime.

Multislot measurements are required for HSCSD technologies as well as for GPRS and EGPRS.

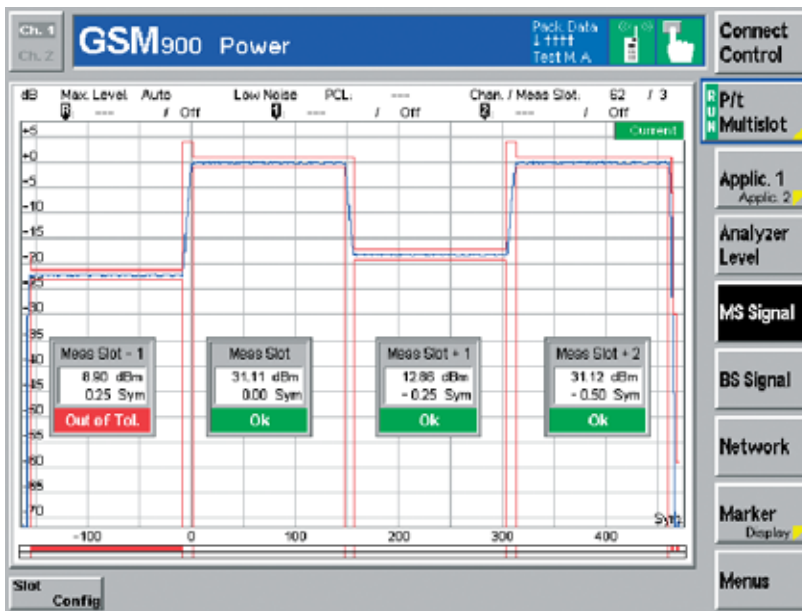

The power-versus-time multislot application can graphically display up to 4 adjacent timeslots, automatically detect GMSK- and 8PSK-modulated signals and activate the associated templates in real-time. A new zoom function allows full-screen display of up to four slots. Moreover, the user can zoom in anywhere along the time or power axis.

8PSK modulation – EDGE

In addition to multislot, a further step toward increasing the mobile radio data rate is 8PSK. By using the available GSM frame structure, the gross data rate is three times that obtained with GMSK. Error vector magnitude and magnitude error have been added to the range of modulation measurements. New templates for power-versus-time measurements ensure compliance with the specifications, as do the modified tolerances for spectrum measurements. As with all measurements provided by the R&S®CMU200, special attention has been given to achieving maximum measurement accuracy and speed for EDGE.

GPRS/EGPRS

With newer, future-oriented methods of packet data transmission, the radio resources of existing GSM mobile radio networks can be utilized efficiently for data services. As with circuit-switched services, GPRS will also use a combination of several timeslots (multislots) and higher-level modulation in the form of 8PSK (EGPRS) to increase the data rate. The introduction of packet-oriented transmission and the associated temporary assignment of radio resources require new test concepts. The R&S®CMU200 provides the following test modes:

3GPP test mode A (GPRS/EGPRS)

In this mode, the mobile phone continuously transmits the associated UL timeslots. The R&S®CMU200 can carry out all TX multislot measurements available, such as the power ramp measurement of up to four adjacent timeslots simultaneously, or modulation and spectrum measurements.

Selecting the coding scheme determines whether the mobile phone is to transmit GMSK- or 8PSK-modulated data. With GPRS/EGPRS, transmission resources are usually allocated temporarily. The uplink state flag (USF) transmitted in the down-link inform the mobile phone that uplink resources have been allocated for the next block and that these resources have to be used. Correct decoding of the highly protected USF sequence is an essential prerequisite for the "dynamic allocation" and "extended dynamic allocation" modes to work properly, and is verified by the R&S®CMU200 by means of the USF BLER test (test modes A and B). Various routines, e.g. USF BLER and false USF detection, are available.

3GPP test mode B (GPRS/EGPRS)

This mode creates a loopback in the mobile phone so that the mobile phone retransmits data blocks received from the R&S®CMU200. To achieve maximum measurement speed, the test mode does not employ the backward error correction function used in packet data transmission, which enables the acknowledgement-based (acknowledged/not acknowledged) retransmission of erroneous data blocks. The transmitter and the receiver are active at the same time. The mobile phone returns the received data blocks to the R&S®CMU200 unchanged, comparable to the loopback mode in circuit-switched operation. The data is looped back after channel coding, which means that the mobile phone's coder and decoder functions are tested as well.

In addition to the measurements available in the 3GPP test mode A, test mode B enables very fast receiver test, bit error rate and Rohde&Schwarz-proprietary block error rate measurements in parallel to transmitter tests (BER/DBLER)

3GPP EGPRS symmetrical and non-symmetrical loopback mode (EGPRS only)

Unlike in test mode B, the data blocks are looped back before they undergo channel coding, i.e. the coders are bypassed in favour of increased measurement speed. In the symmetrical EGPRS loopback mode, 8PSK-modulated data blocks are received in the downlink and returned unchanged in the uplink. In the non-symmetrical mode, 8PSK data blocks are received in the downlink and returned in the uplink as GMSK-modulated data spread over the next three data blocks. Similar to test mode B, the EGPRS loopback mode allows simultaneous transmitter and receiver tests to be performed at an even higher data throughput.

3GPP BLER measurements – acknowledge mode (GPRS/EGPRS)

The BLER measurement mode employs GPRS/EGPRS backward error correction. The R&S®CMU200 sends data blocks in allocated timeslots in the downlink. The mobile phone checks the data blocks for errors (CRC check) and, instead of returning the data blocks, returns only the block acknowledgements in the uplink. The mobile phone transmitter is thus only temporarily active for sending uplink acknowledgements, which means that transmitter measurements are possible only to a limited extent in the BLER mode.

For R&D requirements, the BLER menu opens up a wide range of options to determine receiver characteristics even beyond the scope of the 3GPP test scenarios. The R&S®CMU200 furnishes an average result over all timeslots used, as well as the BLER and the actual data throughput for each timeslot. The downlink transmitter level can be varied separately for each timeslot and is displayed as an important test parameter together with the data throughput and the resulting BLER. The EGPRS BLER measurement is based on a new retransmission algorithm referred to as "incremental redundancy".

Incremental redundancy means that errored blocks are retransmitted using a different puncturing scheme. The R&S®CMU200 can cycle through the puncturing schemes as specified by the 3GPP standard, or start with a specific puncturing scheme, or use the same puncturing scheme throughout (incremental redundancy OFF).

Fast production test mode for test modes A, B and EGPRS loop (GPRS/EGPRS)

Extremely fast adjustment and testing of RF parameters during mobile phone production is ensured by deactivating the GPRS/EGPRS protocol stack. Without using all functions on the higher protocol layer (RLC/MAC layer), the R&S®CMU200 synchronizes the mobile phone (camping), and the data channel (PDCH) is then set up directly without executing the time-consuming routines of location update and GPRS/EGPRS attach. Any signalling for reconfiguring the test setup is likewise omitted. The fast production test mode developed by Rohde&Schwarz provides test conditions comparable to those defined for the 3GPP test modes. The R&S®CMU200 performs all transmitter and receiver measurements described by 3GPP, but at a considerably higher speed.



...making the right connections.

GSM highlights of the R&S®CMU 200

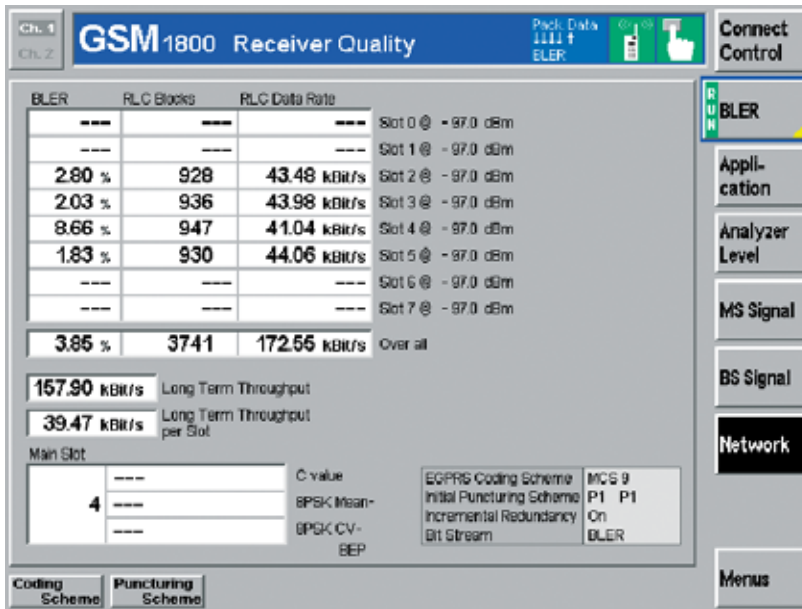

For GPRS/EGPRS, BLER measurements can be performed simultaneously on up to four downlink timeslots. The actual data throughput, the BLER and the resulting data rate (RLC/MAC layer) are displayed separately for each timeslot and as an average for all timeslots used. Furthermore an incremental redundancy performance test is performed, and the channel quality is indicated.

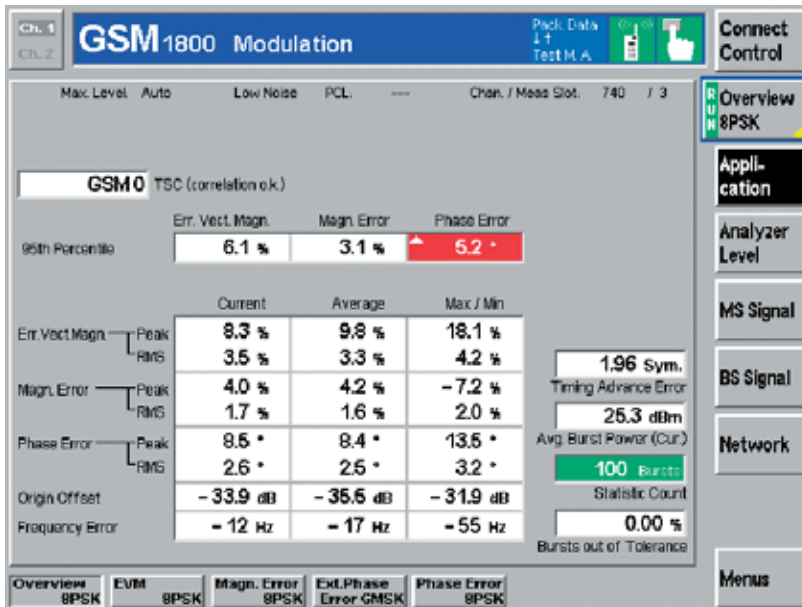

In the 8PSK mode, the modulation analysis is subdivided. The error vector magnitude (EMV), the magnitude error and the phase error can be displayed both numerically as shown above, or graphi-

Benchmark-breaking IEC/IEEE bus speed due to

- ◆ Parallel measurements
- ◆ Fast production test mode (Rohde & Schwarz-proprietary)
- ◆ New fast modulation spectrum measurement (requires R&S®CMU-U65)
- ◆ Optimized processing power using latest DSP generations
- ◆ Statistical BER test based on confidence evaluation

High flexibility for R&D

- ◆ Assignment on up to 8 UL and DL slots (TS 0 to 7)
- ◆ TX/RX on any transmit slot
- ◆ Individual level generation on any DL slot used
- ◆ 3GPP packet data test mode supporting modes A, B and EGPRS loop
- ◆ GPRS/EGPRS TBF reconfiguration during established link
- ◆ GPRS/EGPRS intra-band handover

GMSK/8PSK measurements

- ◆ Phase/frequency error, EVM, magnitude error, origin offset, I/Q imbalance GMSK for I/Q modulator tuning
- ◆ Power versus time
 - On up to 4 UL slots
 - Normal/access
 - Peak power/average, power versus frame, power versus slot
- ◆ High-speed ACP measurement (switching and modulation measurement in parallel) with additional time domain view
- ◆ Timing error
- ◆ BER/DBLER, RBER/FER, FastBER BLER@4DL (GPRS/EGPRS)
- ◆ Incremental redundancy support (EGPRS)
- ◆ Power versus PCL (on 3 or 7 channels)

TDMA in the R&S® CMU200

TDMA overview

The broad acceptance of TDMA (IS-136) is based on its very flexible and powerful technology as well as on its compatibility with AMPS, which is widespread. Derived from analog AMPS, the TDMA standard is ready for step-by-step evolution to the third generation of mobile radio technology. This fact shows the need for a test instrument that is flexible enough to cover all future needs as well as the current standards.

For TDMA (IS-136) signalling functionality, the R&S® CMU200 requires the universal signalling unit (R&S® CMU-B21) as well as the software option R&S® CMU-K27 for the cellular band or R&S® CMU-K28 for the PCS band.

Due to the highly user-friendly menu concept, the R&S® CMU200 provides quick access to all required measurements, optimizing handling and thus efficiency.

Signalling mode

The R&S® CMU200 simulates a TDMA base-station RF interface including the signalling protocol so that a mobile phone can be tested with regard to different signalling parameters. All necessary network and base-station parameters can be set, such as control and traffic channel configuration, neighbouring channels setup, etc. MAHO report can also be generated.

Non-signalling mode

The non-signalling mode is for generating and analyzing TDMA (IS-136) signals in the frequency range from 10 MHz to 2.7 GHz. The R&S® CMU200 provides TDMA-specific measurements such as:

- ◆ Power
- ◆ Modulation
- ◆ Spectrum
- ◆ Power versus time
- ◆ BER

TDMA (IS-136) development

With its superb versatility, the R&S® CMU200 is the most suitable tool for the development of mobile phones. Four configurable RF connectors are provided to enable flexible signal generation and analysis. The power meter can evaluate signals in a range from -80 dBm to +47 dBm, whereas the generator outputs signals from -130 dBm to +13 dBm. The clearly structured and user-friendly menu together with the clear-cut screen layout provide quick access to all features and ensure trouble-free monitoring of the device under test.

Quality assurance

Due to its high measurement repeatability and accuracy, the R&S® CMU200 is the right choice to ensure a consistently high level of quality in production. TDMA-specific measurements such as BER, error vector magnitude (EVM) and EVM10, where only the first 10 symbols are taken into account, provide an excellent test platform to ensure the production of high-quality devices.

Production of mobile phones

The production of mobile phones requires time-efficient and cost-effective means that ensure both high throughput and state-of-the-art accuracy. Owing to the unique IEC/IEEE bus concept of the R&S® CMU200, these two goals can be easily achieved in production lines. The intelligent handling of the received GPIB commands optimizes the measurement speed for all TDMA-specific measurements. In practice, this will mean significantly shorter test time and enhanced test yield.

Acoustic measurements

The implemented ACELP speech coder is able to encode and decode real audio signals and allows the R&S® CMU200 to be used also in real acoustic measurement applications. This is equivalent to the cdma2000 and GSM implementation of the R&S® CMU200. The TDMA speech coder provides analog inputs and outputs and a connector for an external handset. It requires the hardware option R&S® CMU-B52 and can also be combined with the internal Audio Analyzer/Generator R&S® CMU-B41.

The mobile phone reports the received signal strength (RSSI) of the observed channels back to the R&S® CMU where the RSSI is displayed in the MAHO report list. It is possible to configure the neighbouring channels in the network setup. The reported BER can also be monitored.

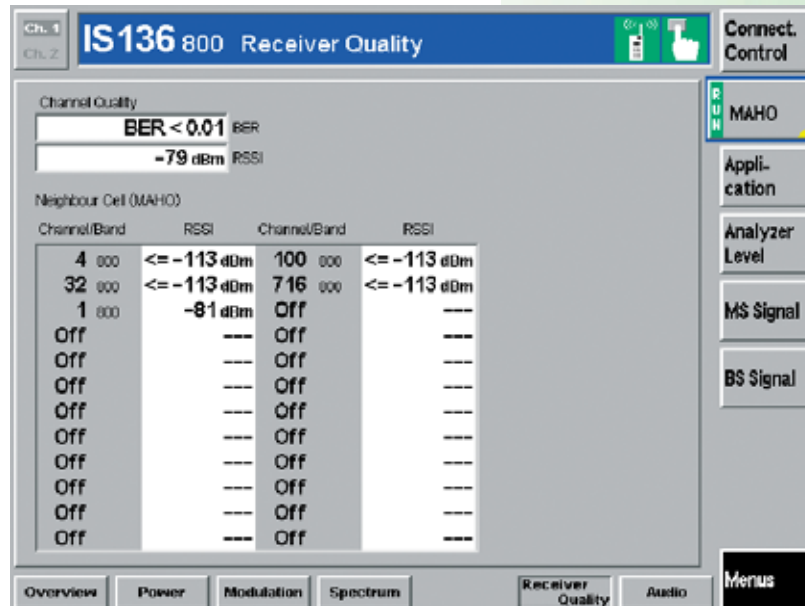

The modulation menu allows the phase error, frequency error and the error vector magnitude to be measured. The measurement results are displayed graphically. Additional measurements such as amplitude droop and timing error are taken as well and displayed numerically in the same screen.

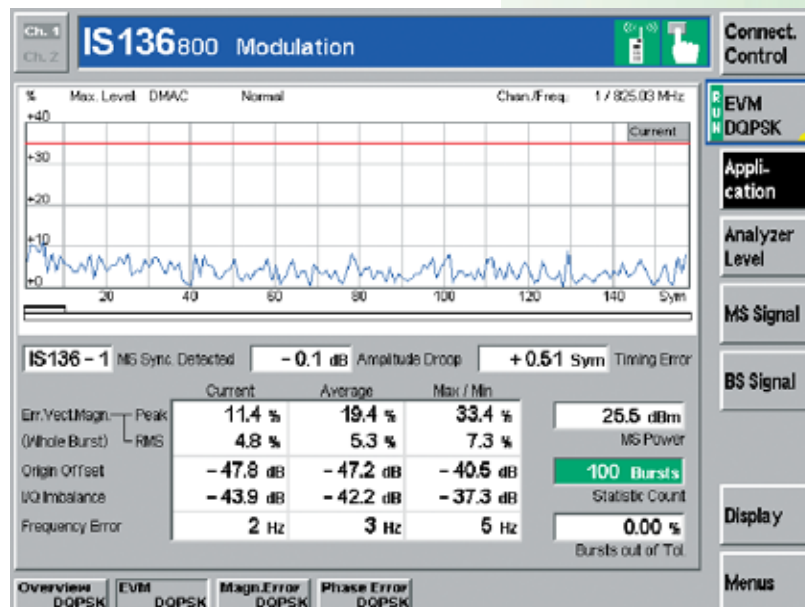

In the power menu, the mobile phone output power of the short burst or the normal burst is displayed. The R&S® CMU200 also enables leakage power measurements which indicate the mobile phone power output in timeslots not used.

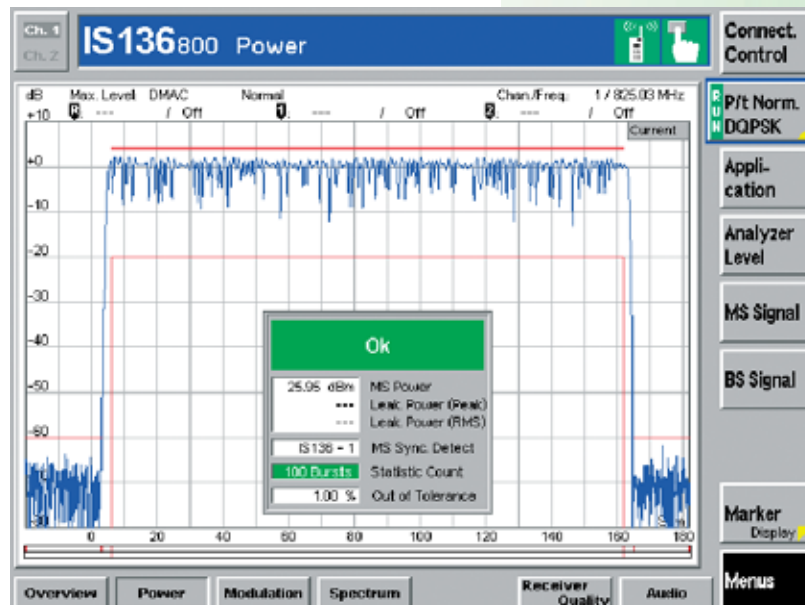

TDMA in the R&S® CMU200

Handoffs

Handoffs are part of the IS-136 specification. Handoffs between PCS and cellular bands as well as from and to AMPS are defined and have to be tested. The R&S® CMU200 supports IS-136 handoffs from 800 MHz to 1900 MHz (interband handoff) and vice versa. Handoffs from 1900 MHz or 800 MHz to AMPS and vice versa are also possible (inter-mode handoff) with the R&S® CMU200.

Switching standards

The flexibility of the R&S® CMU200 makes for quick and simple switching between two different standards. This is very important for IS-136, which is a dual-mode standard containing a digital (TDMA) and an analog mode (AMPS). The handoff between TDMA and AMPS can be achieved by simply pressing a button. This results in a very versatile test concept to improve the flexibility and throughput of production lines.

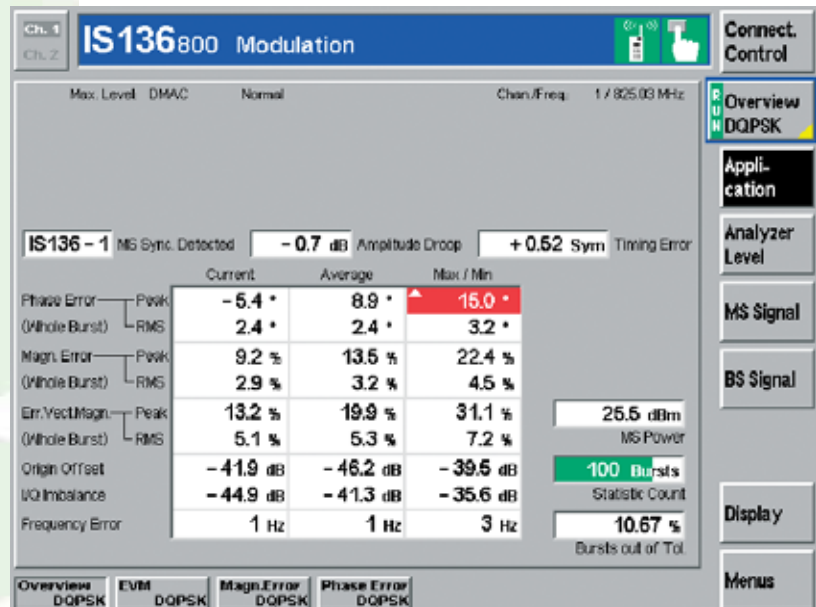

In the modulation overview menu, error vector magnitude (EVM), phase error and magnitude error are measured simultaneously and displayed in a numerical table. The user can choose either EVM, where the entire burst is considered, or EVM10, where only the first ten symbols are taken into account.

TDMA highlights of the R&S® CMU 200

Basic features

- ◆ Call to or from mobile phone
- ◆ Handoff to AMPS
- ◆ Dual-band handoff

Signalling measurements

- ◆ MAHO report
- ◆ Power versus time
 - Short burst
 - Normal burst
- ◆ Modulation
 - Phase error
 - Magnitude error
 - EVM/EVM10
 - Overview of phase/magnitude and EVM simultaneously
- ◆ Spectrum
 - Adjacent channel power due to switching or modulation
- ◆ Overview
 - Signalling information

Non-signalling measurements

- ◆ Modulation
- ◆ Spectrum
- ◆ Power versus time
- ◆ BER

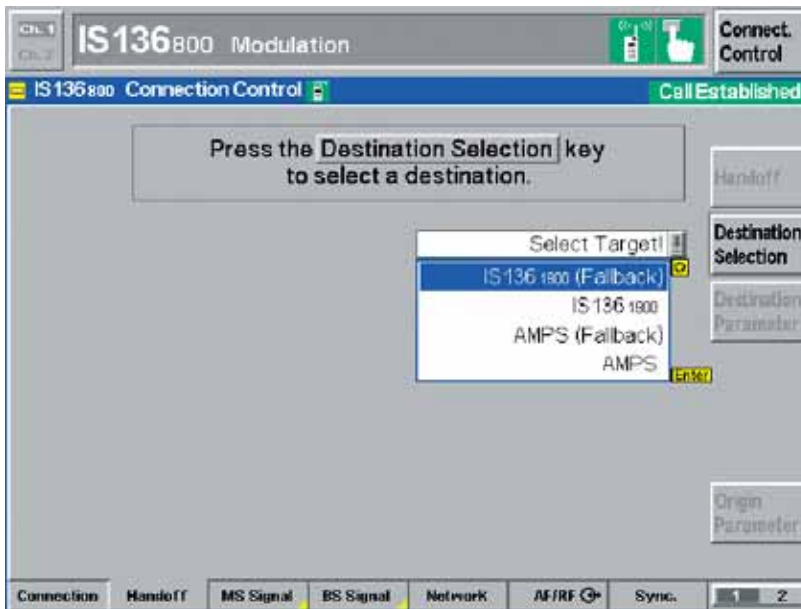

Handoffs from cellular band (800 MHz) to PCS band (1900 MHz) can be tested as well as to and from AMPS. Before handoff to a new network, the parameters for the target network can be set. This results in a large variety of different test scenarios.

AMPS in the R&S®CMU200

AMPS overview

Analog AMPS (advanced mobile phone system) is a standard system for analog mobile phone service in the United States and is also used in other countries. It is based on the frequency spectrum allocation for cellular service established by the Federal Communications Commission (FCC) in 1970. Introduced by AT&T in 1983, AMPS became the most widely deployed cellular system in the United States.

AMPS options

Although AMPS is a 1st generation analog standard, a substantial demand for mobile radio testers covering this standard will continue to exist in the future. Especially in the United States, dual-mode cdma2000/AMPS and TDMA/AMPS phones are very common. By combining the digital standards with analog AMPS, the network operators offer their customers the advantages of the digital standards and ensure nearly 100% coverage in North America. As a consequence, Rohde&Schwarz is offering analog AMPS in addition to the digital standards TDMA and cdma2000. These options add analog AMPS functionality to the R&S®CMU200 base unit:

- ◆ R&S®CMU-B21 (universal signalling unit)
- ◆ R&S®CMU-B41 (audio generator/analyzer)
- ◆ R&S®CMU-K29 (AMPS test software)

The hardware options R&S®CMU-B21 and R&S®CMU-B41 are suitable for other standards as well.

AMPS measurements and features

As for other standards, there are two categories of AMPS measurements:

- ◆ Transmitter tests for verifying the transmit part of a mobile phone
- ◆ Receiver tests for verifying the receive part of a mobile phone

AF level search routine

The AF level search routine in the TX test menu allows the user to set the desired frequency deviation of the mobile phone transmitter at a keystroke, the level of the R&S®CMU200 modulation generator being automatically corrected.

Sensitivity search routine

The sensitivity search routine in the RX test menu automatically searches for the receiver input level at which a selectable

SINAD of the demodulated signal can still be attained.

The following lists provide an overview of the most important tests implemented in the R&S®CMU-K29 option.

Transmitter measurements

- ◆ Carrier power
- ◆ Carrier frequency error
- ◆ SAT frequency error/peak deviation
- ◆ ST frequency error/peak deviation
- ◆ Modulation noise and distortion
- ◆ Hum and noise
- ◆ Electrical AF response
- ◆ Modulation distortion
- ◆ Residual AM

Receiver measurements

- ◆ Sensitivity
- ◆ Hum and noise
- ◆ SINAD
- ◆ Distortion
- ◆ AF voltage

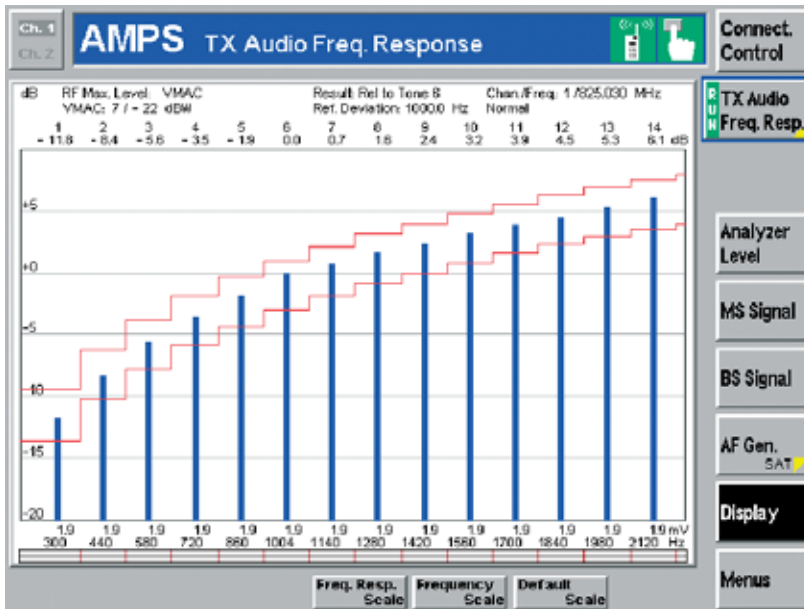

TX AF response measurement: the pre-emphasis characteristic of the mobile phone transmitter is verified by a single-shot measurement.

- ◆ Electrical AF response
- ◆ Residual AM
- ◆ Audio deviation

All the filters required for the measurements are of course preconfigured in line with specifications, but their settings can be modified for individual measurements. The RX and TX electrical AF response measurements in AMPS are usually defined as

frequency sweep versus AF range. The R&S®CMU 200 offers a much faster and more modern alternative.

Using the TX and RX AF response menus of the R&S®CMU 200, the AF response is measured simultaneously at 20 test points with user-programmable level and fre-

AMPS highlights of the R&S®CMU 200

Benefits of base unit

- ◆ Platform supporting cdma2000, TDMA and AMPS in one box
- ◆ Wide frequency range allowing dual-mode/dual-band testing required for cdma2000 and TDMA
- ◆ See base unit section

AMPS features

- ◆ Powerful signalling capabilities
- ◆ Base station simulation
- ◆ Mobile or base station originated call connect/disconnect
- ◆ Short measurement time ensuring high throughput
- ◆ Combined measurements
- ◆ Benchmark-breaking IEC/IEEE bus speed
- ◆ Simple interactive operation, standardized MMI
- ◆ No specialized network knowledge required
- ◆ Various handoffs from cdma2000/TDMA and to TDMA supported

1xEV-DO in the R&S® CMU200

1xEV-DO overview

cdma2000 1xEV-DO (TIA/EIA/IS-856), officially recognized by the ITU as an IMT-2000 3G standard, is the latest step in cdma2000 evolution. The new standard provides a "data only" mode (no voice traffic) with data rates up to 2.4 Mbit/s in the forward link and up to 153.7 kbit/s in the reverse link. 1xEV-DO uses a dedicated carrier with the same 1.25 MHz bandwidth per carrier as cdma2000 1x and is optimized for the delivery of high-speed wireless data to mobile terminals as well as fixed wireless devices. Due to the compatibility with existing cdma2000/IS-95 networks (same cell sites, towers and antennas can be used), more and more cdma2000/IS-95 operators worldwide will upgrade their networks to 1xEV-DO service.

1xEV-DO test concept

Recent production measurement trends have been moving away from "call established" based or "signalling" based testing toward a "module" or "non-signalling" strategy. The main advantage of this approach is reduced test time in comparison to full signalling tests. It is possible to implement vendor-specific tests/procedures and easier to add new test scenarios as the DUT matures. In addition, lack of symmetry between forward and reverse links makes traditional loopback testing less effective.

With the 1xEV-DO option, the R&S® CMU200 now offers a very flexible all-in-one solution including a 1xEV-DO generator for receiver measurements of 1xEV-DO access terminals as well as an extensive list of transmitter measurements. The test concept is based on the factory test mode (FTM) which provides direct control of the DUT without complete signalling. The FTM is implemented via the serial diagnostic monitor interface which is already present in most 1xEV-DO terminal designs. The factory test mode minimizes test configuration and transition time between tests and allows simultaneous testing of different DUTs. Enhanced measurement times and optimized test sequences are a special benefit especially in production environments, yielding higher throughput.

1xEV-DO options

The 1xEV-DO option within the R&S® CMU200 is based on the cdma2000 1x Signalling Unit R&S® CMU-B83. To upgrade the R&S® CMU200 with 1xEV-DO functionality, the following options are required:

- ◆ R&S® CMU-B83
cdma2000 1x signalling unit
- ◆ R&S® CMU-U65
3G measurement DSP and performance accelerator
- ◆ R&S® CMU-B88
cdma2000 1xEV-DO extension board for cdma2000 signalling unit R&S® CMU-B83
- ◆ R&S® CMU-K88
cdma2000 1xEV-DO test software

1xEV-DO generator

The extremely flexible 1xEV-DO generator was designed to provide, not only a limited live control channel but also traffic for up to four different access terminals simultaneously. This allows receiver measurements for up to four separate access terminals at the same time.¹⁾

Each of the four different traffic channels can be configured independently. The user-specific parameter set includes

- ◆ MACIndex
- ◆ MACLevel
- ◆ Data rate
- ◆ Data pattern
- ◆ Transmission interval
- ◆ Power level
- ◆ DRCLock mode
- ◆ Reverse power control mode

The reverse power control system that is implemented allows extensive range tests to be performed (independently for each user) by sending a series of specific power-control bit patterns to the access terminal or by using an external power control bit source.

The access network also supports a complete set of parameter settings: PN offset, reverse activity bit state, AWGN, power and channel, which can be configured easily. To simulate different conditions in a real network, up to 55 other users (comparable to OCNS in cdma2000) are supported by the 1xEV-DO generator.

¹⁾ Multiple-user support depends on the data multiplexing mode used.

Test setup: A test system using a factory test mode (FTM) is virtually identical to most protocol-based production test setups. It consists of a test controller, a radiocommunication tester with 1xEV-DO option and the actual device under test. The primary difference is that the device under test operates in the FTM mode while the test sequence is being performed.

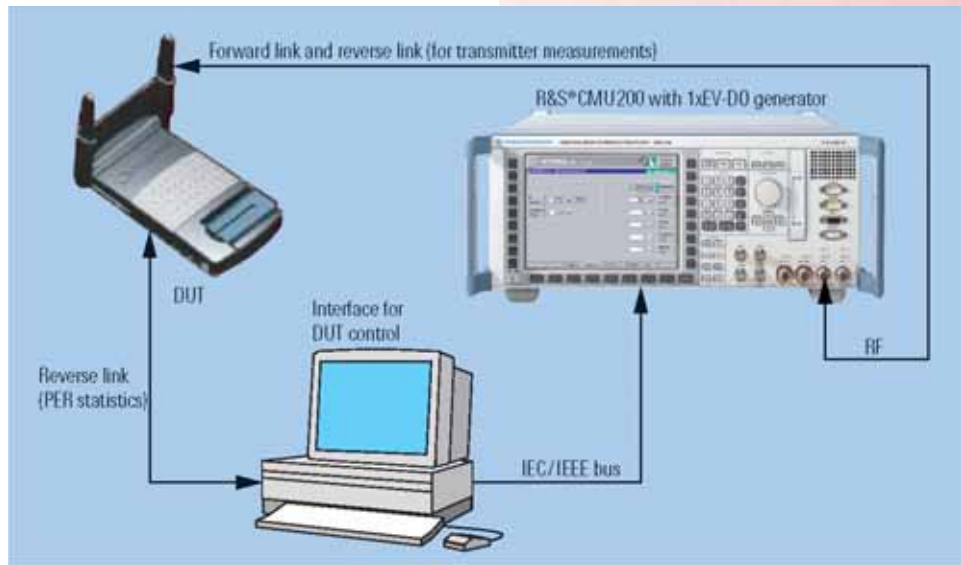

Channel filters: Three different channel filters allow the reverse link signal to be analyzed in eight different signalling states. Users may select whether or not to measure the signal at the time when ACK, DATA or DRC channel is transmitted (ON or OFF). All modulation measurements as well as the code domain power measurement support the channel filters.

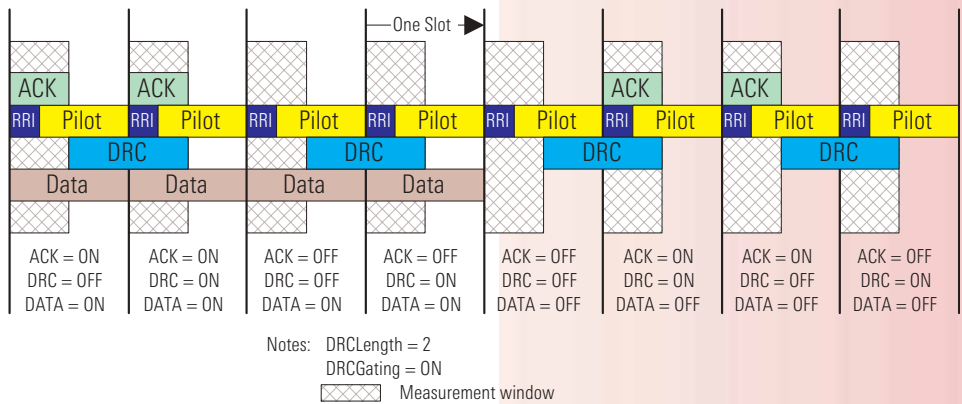

The spectrum measurement provides comprehensive ACPR measurements at four different user-definable frequencies in a ± 2 MHz range.

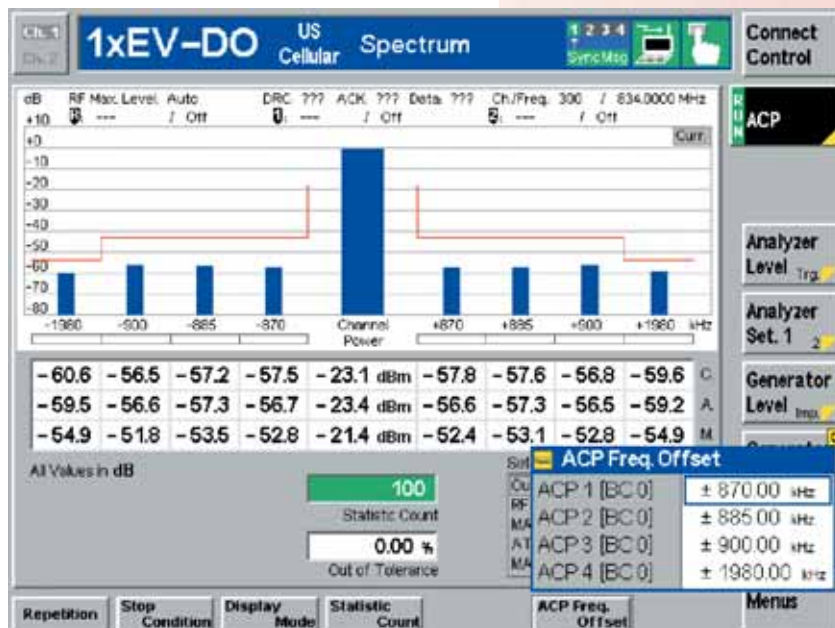

1xEV-DO in the R&S®CMU200

1xEV-DO measurements

The R&S®CMU200 provides a complete set of extremely fast transmitter measurements. Most of the measurements are presented in graphical form which makes the test solution ideal for R&D. The modulation analyzer allows the reverse link signal to be evaluated in eight different states (DATA on/off, DRC on/off, ACK on/off)

Since receiver testing can be performed in parallel by the access terminals, the R&S®CMU200 is the perfect solution for the production of 1xEV-DO access terminals.

The list below shows the implemented 1xEV-DO measurements:

Power measurements

- ◆ General power measurement (e.g. for fast power phasing)

Code domain power

- ◆ Code domain power
- ◆ Code domain error power
- ◆ Channel power

Modulation measurements

- ◆ Error vector magnitude (EVM)
- ◆ Magnitude error
- ◆ Phase error
- ◆ I/Q analyzer

Spectrum measurements

- ◆ 30 kHz spectrum analyzer filter at four frequency offsets (user-configurable); max. frequency offset 2 MHz

Receiver measurements

- ◆ Via DUT control interface in test controller – RF signal data for up to four ATs may be generated in parallel by the R&S®CMU200

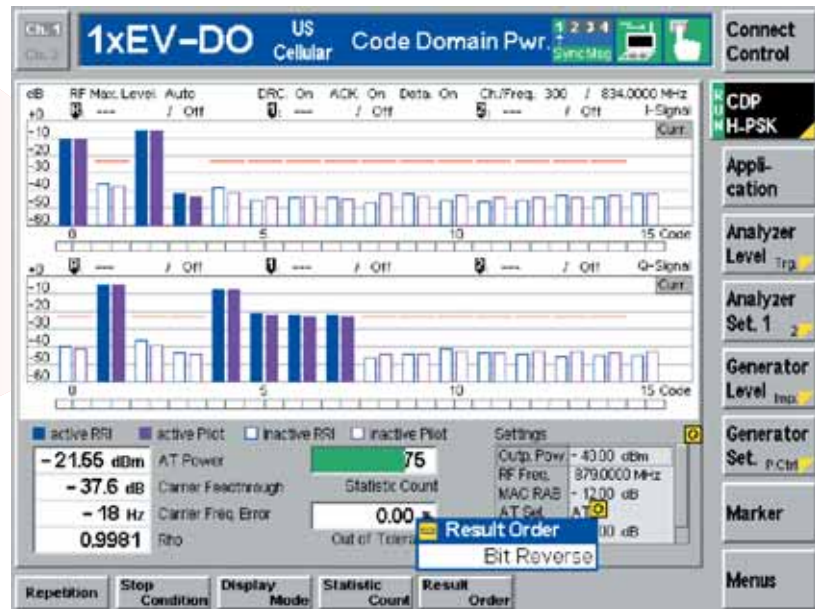

Code domain power measurement:

The code domain power (CDP) includes the time-switching component between RRI and pilot channel. The "blue" bar displays the CDP for the time the RRI channel is up. The "purple" bar shows the CDP value for the time the pilot channel is up.

1xEV-DO highlights

- ◆ Simultaneous testing of up to four access terminals
- ◆ Reduced test times in comparison to full signalling tests
- ◆ Extremely flexible 1xEV-DO generator allows vendor-specific tests and new test scenarios
- ◆ Channel filters allow the reverse link signal to be evaluated in eight different states
- ◆ Combines 1xEV-DO with cdma2000 test applications in one box for dual-mode cdma2000/1xEV-DO testing
- ◆ All band classes used are supported
- ◆ Code domain power includes time switching between RRI and pilot channel
- ◆ Different network conditions can be simulated by a user-definable number of additional users in the forward link

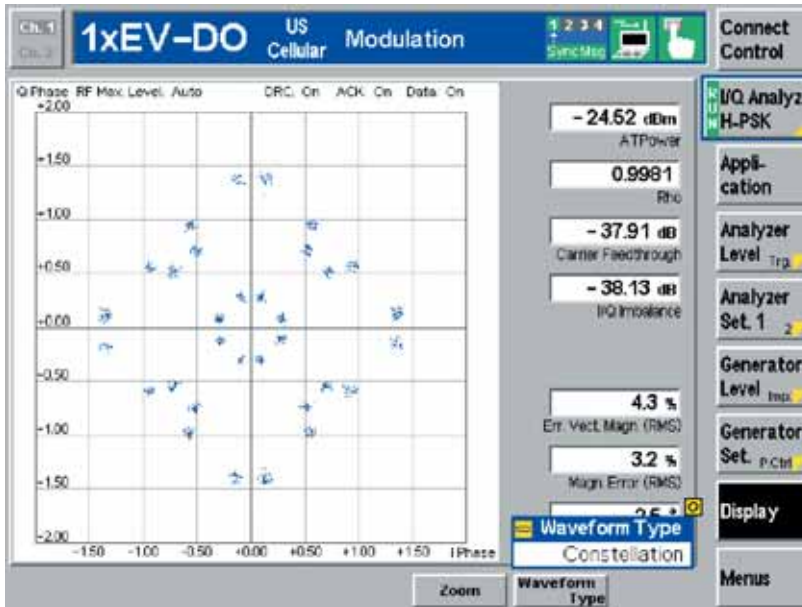

The I/Q analyzer provides a constellation diagram as well as an eye pattern for the I and Q component.

cdma2000 1X in the R&S® CMU 200

cdma2000 overview

cdma2000 arose from the further development of cdmaOne (TIA/EIA-95) and is an enormous step toward 3G. Besides higher data rates and considerably improved efficiency, cdma2000 is particularly noteworthy for its downward compatibility with cdmaOne. Nine different configurations (radio configurations RC1 to RC9) in the forward link and six radio configurations in the reverse link define the different connections which are specified in the IS-2000 standard.

- ◆ RC1 and RC2 define cdmaOne connections for rate set 1 and rate set 2
- ◆ RC3 to RC5 in the forward link (or RC3 to RC4 in the reverse link) define cdma2000 connections for spreading rate 1 (cdma2000 1X)
- ◆ RC6 to RC9 in the forward link (or RC5 to RC6 in the reverse link) are cdma2000 connections for spreading rate 3 (cdma2000 3X) only

Compared to cdmaOne, cdma2000 1X doubles the capacity for pure voice transmission and provides a maximum packet data rate of 307 kbit/s on a single 1.25 MHz carrier. cdma2000 1X is a recognized IMT-2000 3G standard, already successfully deployed in multiple networks over several continents.

R&S® CMU cdma2000 1X options:

The cdma2000 standard within the R&S® CMU 200 was launched in December 2001. By supporting the cdma2000 standard, Rohde&Schwarz is enhancing the cdma2000 1X functionality to meet customer needs today as well as in the future.

The central component of the cdma2000 1X option is the Signalling Unit R&S® CMU-B83, which is a prerequisite for enabling cdma2000 1X functionality in the R&S® CMU 200. The R&S® CMU-B83 is designed for maximum conformance to the standard. The R&S® CMU-B83, of course, not only supports pure cdma2000 1X high-speed data links, but also enables the links of the previous TIA/EIA-95A/B standards.

cdma2000 1X is used in various frequency ranges. The standard currently defines more than ten different band classes, all of which can be supported by the R&S® CMU 200 with its universal hardware concept¹⁾.

The following options are available for cdma2000 1X:

- ◆ R&S® CMU-B83: cdma2000 signalling unit (essential)
- ◆ R&S® CMU-U65: 3G measurement DSP and performance accelerator (essential)
- ◆ R&S® CMU-K83: cdma2000 1X software for the 450 MHz band (band class 5)
- ◆ R&S® CMU-K84: cdma2000 1X software for cellular bands
- ◆ R&S® CMU-K85: cdma2000 1X software for PCS bands
- ◆ R&S® CMU-K86: cdma2000 1X software for IMT2000 band (band class 6)
- ◆ R&S® CMU-B85: 8k QCELP, 8k EVRC, 13k QCELP speech coder
- ◆ R&S® CMU-B87: layer 3 message monitor software
- ◆ R&S® CMU-U80: gpsOne trigger output connector

The universal hardware and software concept of the R&S® CMU 200 represents the optimum solution for the development and challenges of the CDMA standard over the next few years.

¹⁾ The R&S® CMU 200 already supports band classes BC0 to BC10. Additional band classes can be integrated easily if there is a market requirement.

cdma2000 1X functionality

Similarity in physical conditions and downward compatibility make the cdma2000 1X T&M concept very similar to that of cdmaOne. There are, however, major differences in the protocols.

The R&S® CMU 200 supports connections in all radio configurations defined for cdma2000 1X, i.e. TIA/EIA-95 connections as well as the usual cdma2000 1X high-speed connections.

Code domain power is a new and highly important measurement for mobile phones in cdma2000. Since several code channels are now transmitted simultaneously in the reverse link, it is necessary to check whether the power distribution of the different channels complies with the test specification (TIA/EIA-IS-98-E) for cdma2000. The measurement concept in the R&S® CMU 200 is based on ProbedSP™ technology, which permits high-speed measurement of the code domain power. The emphasis is on fast measurements and clear and concise representation.

Of course, the R&S® CMU 200 also supports the requirements placed on the gpsOne test application; the R&S® CMU 200 meets the high demands for frequency and phase accuracy.

The cdma2000 1X implementation in the R&S® CMU 200 is based on the TIA/EIA IS-2000 Rev. 0 standard. However, features of Rev. A are partly implemented. The R&S® CMU 200 currently supports, for example, FER measurements on two supplemental channels (SCH0 and SCH1).

Within a TDSO (SO 32) connection, the frame error rate (FER) on the fundamental channel (FCH) as well as on the supplemental channels SCH0 and SCH1 can be evaluated (as soon as cdma2000 handsets support SCH1).

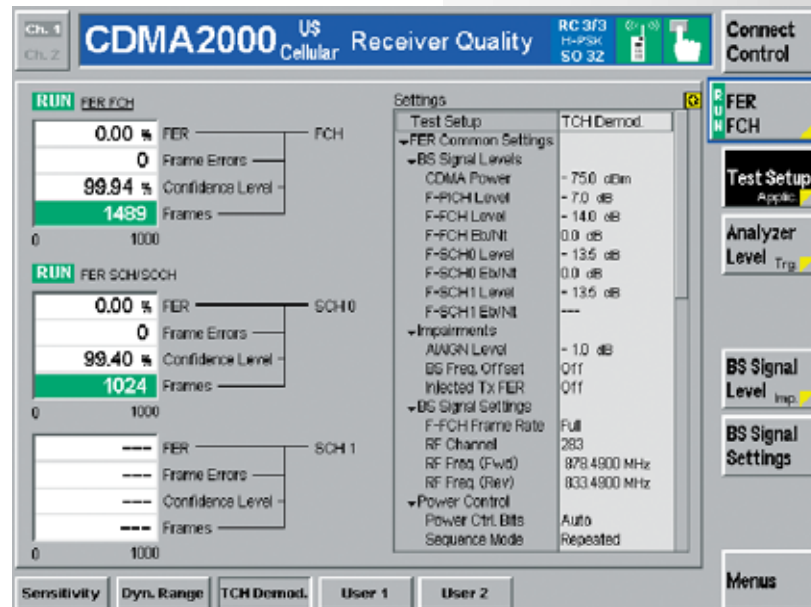

Code domain power is a highly important measurement for mobile phones in cdma2000. Since several code channels are transmitted simultaneously in the reverse link, it is necessary to check whether the power distribution of the different channels complies with the test specification (TIA/EIA-IS-98-E).

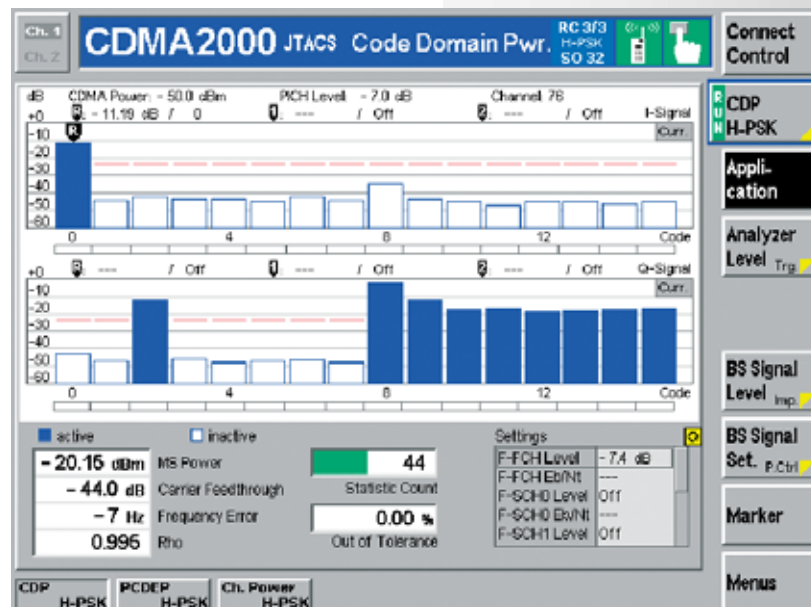

The spectrum measurement provides comprehensive ACPR measurements at four different user-definable frequencies in a ± 2 MHz range.

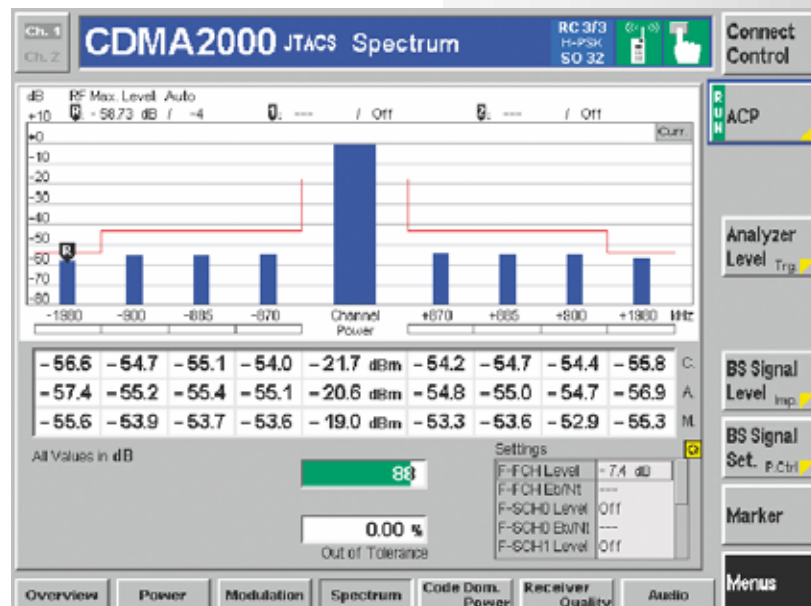

The R&S® CMU200 provides a large set of different connection types (service options), making the tester ideal for R&D purposes. The following are currently possible:

- ◆ Test loop service options:
SO 2, SO 9, SO 55
- ◆ Speech service options:
SO 1, SO 3, SO 17, SO 0x8000
- ◆ Test data service option:
SO 32
- ◆ IP end-to-end data connection:
SO 33
- ◆ Short message service (SMS):
SO 6, SO 14

The R&S® CMU-B85 speech coder option is a unique feature within the R&S® CMU200. The capability to encode external audio signals and to decode digital cdma2000 signals to analog audio makes the R&S® CMU200, in combination with an external audio analyzer such as the R&S® UPL16, suitable for high-precision acoustic measurements on cdma2000 mobile phones.

The layer 3 message monitor (option R&S® CMU-B87) is an extremely helpful tool for analyzing and verifying the correct implementation of the protocol stack. This Windows-based software displays and stores single messages or complete test sessions. Analysis can be performed offline, online or via the local area network (LAN).

All relevant base station parameters and connection settings can be configured in user-friendly menus.

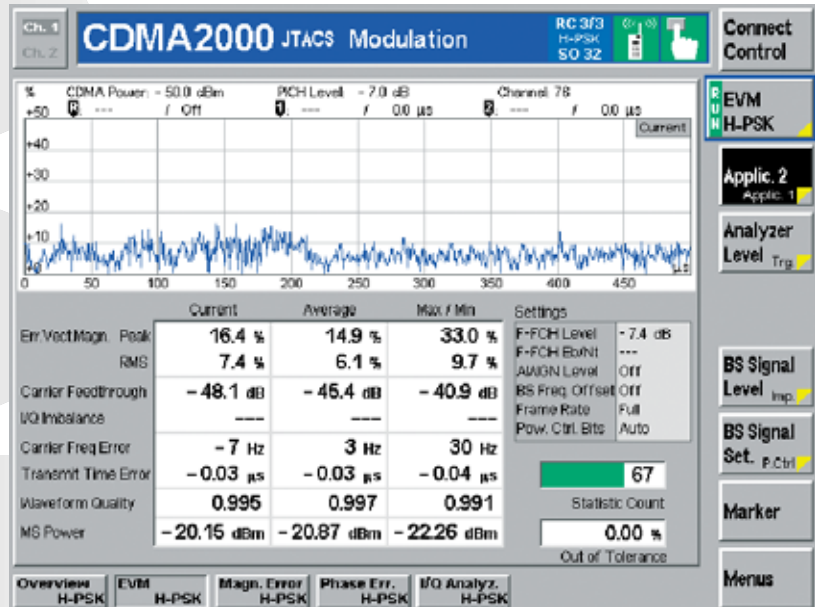

Modulation measurements allow users to check the MS transmitter. Parameters such as EVM, phase error and frequency error are displayed graphically.

Signalling mode

The range of functions is as follows:

- ◆ Power measurements
 - Minimum/maximum output power
 - High-speed channel power
 - Gated output power
 - Open-loop time response
 - Access probe power
 - Standby power
 - Range tests by using user-configurable power control bit patterns
- ◆ Receiver quality measurements
 - Frame error rate (FER) on FCH, SCH0 and SCH1
 - Dynamic range, sensitivity and other user-selectable test environments:
 - FER injection
 - Forward power control measurement

cdma2000 highlights of the R&S® CMU 200

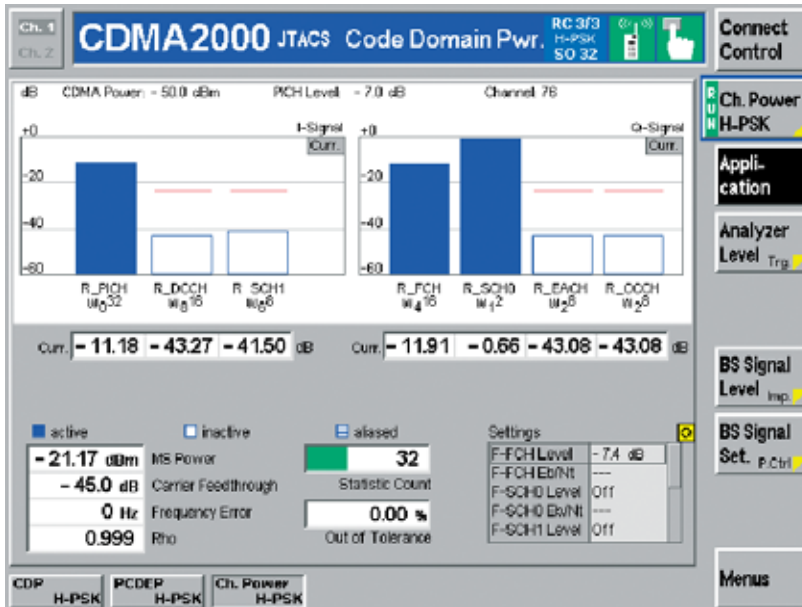

The channel power measurement displays the power in the channels used by the reverse link, separated into I and Q signals.

Non-signalling mode

- ◆ Modulation (both RC1/2 and RC3/4)
 - Error vector magnitude (EVM), magnitude error, phase error, waveform quality, carrier feedthrough, frequency error, eye diagram, constellation/vector diagram
- ◆ Code domain power
 - Code domain power
 - Peak code domain error power, channel power
- ◆ Handoffs
 - Implicit handoffs (RF channel, Walsh code, PN offset, frame offset)
 - Interband handoff
 - Handoff to AMPS
- ◆ Sideband suppression

- ◆ High-speed power measurement
- ◆ Frequency error
- ◆ Waveform quality (both RC1/2 and RC3/4)
- ◆ Carrier feedthrough
- ◆ Transmit time error
- ◆ Sideband suppression

- ◆ cdma2000 speech coder for high-precision acoustic measurements
- ◆ Multiple connection types to cover most important test requirements in R&D, production and high-level service labs
- ◆ Forward closed-loop power control tests as specified in IS-98E sections 3.4.7, 3.4.8, 3.4.9 supported
- ◆ Quick paging channel implemented
- ◆ Handoffs possible between service options and between cdma2000 and IS-95 connection types during an established call
- ◆ Measurements under fading conditions supported (baseband fading; requires option R&S® CMU-B17 in combination with a fading generator such as the R&S® ABFS)
- ◆ Voice loopback and comprehensive testing of mobile phones
- ◆ Full support of RC1/RC2 (cdmaOne measurements) and RC3/RC4 (cdma2000)
- ◆ Support of all band classes specified in IS-2000
- ◆ Innovative measurement of code domain power, code domain peak error power, channel power
- ◆ Parallel RX/TX measurements ensuring high throughput in production environments
- ◆ Graphical representation of measurement results best suited for R&D labs
- ◆ Readout and display of many mobile-phone-specific parameters (ESN, slot cycle index, etc)
- ◆ Extremely fast measurements
- ◆ Non-signalling and signalling mode
- ◆ Various handoffs supported (e.g. handoff to AMPS, interband handoff)

WCDMA in the R&S® CMU200

The need for higher data rates is the consequence of an information-oriented society in the new millennium. The enhancement of mobile devices takes this need into account. Next-generation wireless communication poses new challenges as a consequence. Driven by ideas of the first and second generation (SIM, global roaming, CDMA technology, data services), WCDMA takes all fundamentals to unprecedented levels and adds new application fields as well as application-tailored data security. Derived from Asian, American and European ideas, 3G networks are the mobile solution for future needs as well as the current mainstream.

WCDMA FDD functionality

The tests provided by the R&S® CMU200 are currently based on the 3GPP/FDD Release 99 WCDMA radio link standards. Regular adaptations to new releases and baselines will be made available as the standard evolves; thus the R&S® CMU200 is already prepared for Release 5. Most of the measurements offered comply with the 3GPP specification TS 34.121, chapter 5 (Transmitter Characteristics), chapter 6 (Receiver Characteristics) and chapter 7 (Performance Tests). The R&S® CMU200 can be fitted with an FDD transmitter tester, an additional FDD generator, and FDD signalling hardware. Depending on the application, only the first or the first two might be needed, allowing T&M budgets to be optimized. The three parts allow the R&S® CMU200 to be configured for non-signalling TX, TX/RX or signalling TX/RX measurements and functional testing on the UE (user equipment) according to 3GPP specification. Due to the highly user-friendly menu concept, the R&S® CMU200 provides quick access to all required measurements and optimizes the handling and thus the efficiency of

complex measurement tasks with appropriate status messages and built-in statistical functions.

Different handover capabilities within WCDMA/FDD such as inter-frequency handover are available in the R&S® CMU200 WCDMA solution. Moreover, handover to other cellular networks such as GSM, i.e. inter-RAT handovers, are implemented and will also be expanded depending on the specification progress.

Non-signalling mode

The non-signalling mode is for generating and analyzing WCDMA (3GPP/FDD) signals in the full frequency range of the R&S® CMU200 base unit. The R&S® CMU200 provides WCDMA-specific TX measurements on signals with up to six DPDCHs such as

- ◆ ACLR (adjacent channel leakage power ratio): two measurement modes, filter (bar graph) and FFT (cont. spectrum) method; absolute or relative readout
- ◆ OBW (occupied bandwidth)
- ◆ SEM (spectrum emission mask)
- ◆ CDP (code domain power): CDP vs all codes, CDP vs DCH channels, RHO versus all codes, RHO versus DCH channels; all measurements in relative or absolute readout
- ◆ Modulation (for 3GPP or general QPSK): EVM (error vector magnitude), magnitude error, phase error, frequency error, I/Q offset, I/Q imbalance, peak code domain error, RHO (waveform quality), I/Q constellation/vector/eye diagram
- ◆ Power: MAX, MIN, OFF (UE test mode)
- ◆ Power versus slot, inner-loop power

The non-signalling mode allows tests of all essential RF parameters of the connected UE where autoranging for the received UE signal is also applied.

The measurements are performed in unsynchronized mode. No call is set up to evaluate UE performance using this mode. No 3GPP FDD generator option is needed. The capability to use different 3G dedicated triggers such as signalling trigger, IF trigger, etc, together with the flexible trigger settings such as delay and delay offset make this an interesting tool for R&D applications where a protocol stack is not available. Dedicated level service facilities can also be supported.

Reduced signalling synchronized mode

This mode requires the 3GPP FDD generator option to be installed. This generator for the R&S® CMU200 provides all necessary forward link channels and 3GPP-conforming orthogonal noise signals. 16 channels of OCNS can be added and their power levels changed.

The generated channels and available functions include

- ◆ P-CPICH/P-SCH/S-SCH/P-CCPCH/PICH/DPCCCH/DPDCH
- ◆ TPC profiles (three predefined, one user-defined setting, seven user-selectable, five definable TPC setups)
- ◆ OCNS (16 orthogonal channels)

The R&S® CMU200 generator can also provide non-channel coded data on the physical layer and allow slot formats from 0 through 16 to be selected.

A synchronization of the UE (but still no call setup) is mandatory for RX evaluation, synchronized TX measurements and additional TX measurements such as

- ◆ Inner-loop power control with TPC commands:
TPC stepping measurement (UE receives TPC commands from the R&S®CMU200 generator)
- ◆ Receiver quality: BER, BLER (two modes, UE-assisted evaluation or RF loopback (realtime receiver option needed))

In conjunction with the Baseband Fading Simulator R&S®ABFS and the R&S®CMU200 with optional I/Q/IF interface (see I/Q and IF interfaces for the R&S®CMU200), conditions of fading may be simulated and the results evaluated with the R&S®CMU200. In contrast to RF fading, a baseband fading scenario allows the extremely high forward link (downlink) accuracy provided by the R&S®CMU200 3GPP FDD generator to be maintained. In addition, baseband-faded testing usually comes at a much lower cost than an RF fading solution. All fading tests are possible in synchronized or signalling mode. The optional I/Q/IF interface can also be used for baseband testing when no RF section of the UE is available in R&D.

FDD signalling mode

Signalling tests are tests in an environment closer to a true live network. 3GPP currently specifies three different operating bands for FDD (bands 1 through 3). All three bands are optionally supported by the R&S®CMU200. The measurements offered are largely the same as performed in synchronized mode. In signalling mode, the R&S®CMU200 simulates one WCDMA base-station RF interface

In the connection folder of the connection control menu, all relevant R&S®CMU200 connection settings are displayed together with the reported UE capabilities. The main control buttons to initiate and release different connection types are located here.

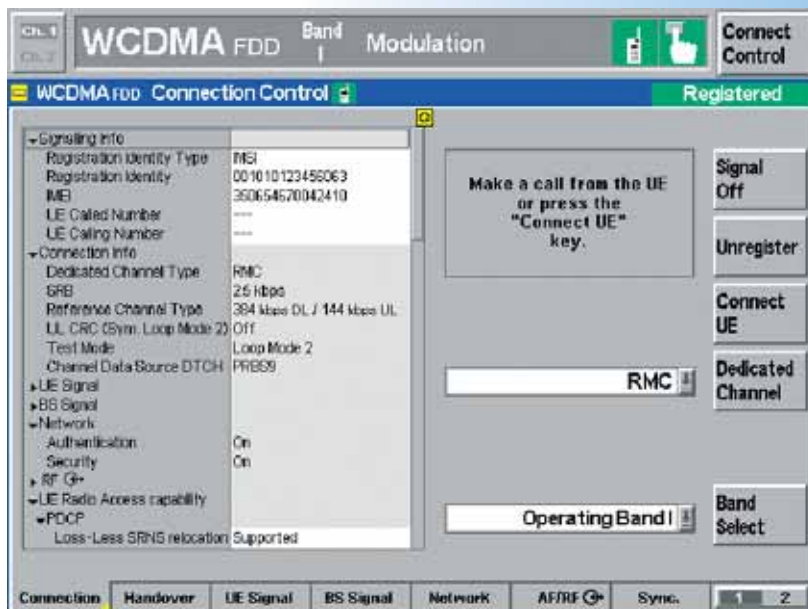

This screen shows the receiver sensitivity measurement on a UE at -110 dBm PCPICH (-117 dBm DPICH) in test-loop mode 2. The R&S®CMU200 also provides a "lost transport blocks" counter for easier troubleshooting.

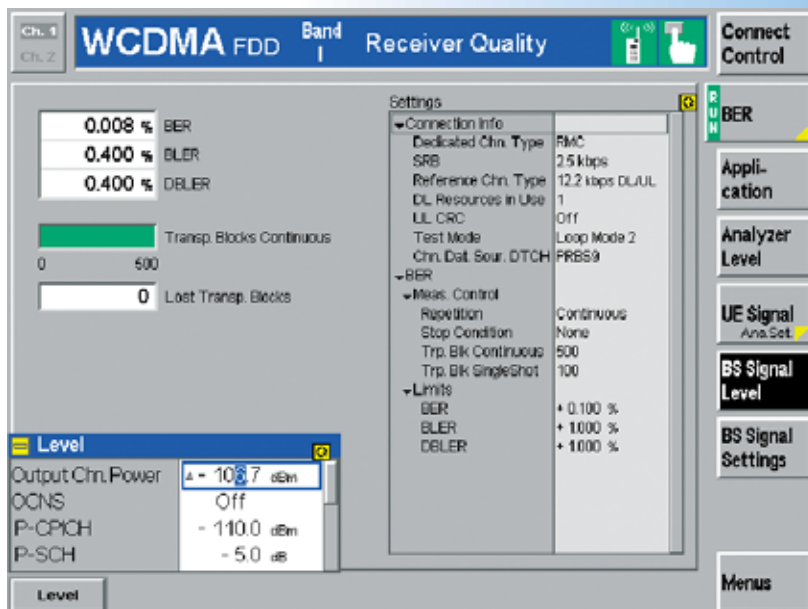

Shown here is a typical output power response to TPC commands of a UE under test. The inner-loop power control measurement can be used in algorithms 1 and 2 with different step sizes. Here algorithm 1 with 1 dB step size is used. In the lower half of the graphics screen, the analysis of the UE response is displayed.

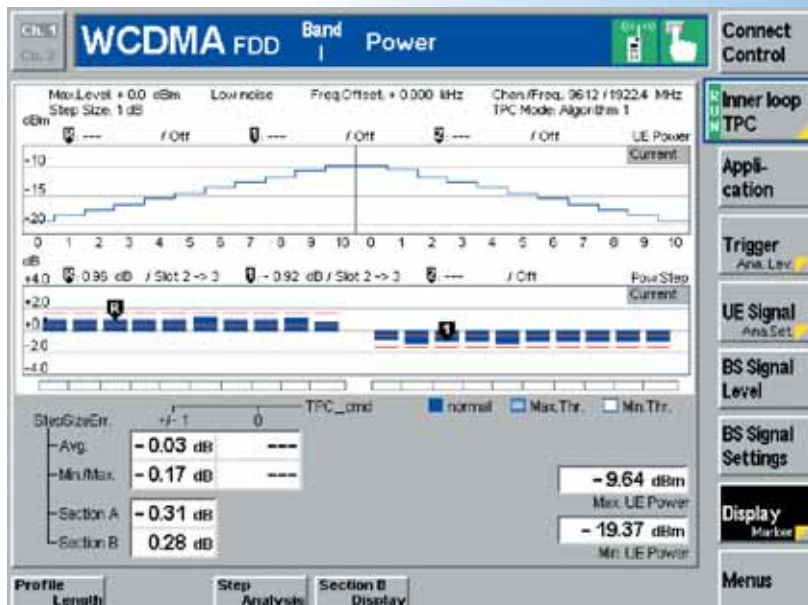

WCDMA in the R&S® CMU200

including the signalling protocol so that an FDD UE can be tested with regard to various signalling parameters. All necessary network and Node B (base station) parameters such as control and data channel configurations can be set. In addition to the non-signalling tests, R&S® CMU200 provides features such as

- ◆ Dynamic setting of signalling parameters
- ◆ RRC connection setup
- ◆ Readout of UE capabilities
- ◆ Authentication and security (integrity)
- ◆ Call setup (MOC, MTC)
- ◆ Call release (NIR, MIR)
- ◆ Measurements from non-signalling section (except I/Q constellation/vector/eye diagram and power vs slot)
- ◆ Power control: open-loop power control, inner-loop power control (3GPP mode), target power
- ◆ Test mode/Test loop activation command (test loop mode 1 transparent and test loop mode 2 with and without uplink CRC)
- ◆ Receiver quality: BER, BLER, DBLER (RF loopback)
- ◆ Readout of part of UE measurement reports
- ◆ Voice connection with selectable audio loopback

The measurements can be performed on different radio access bearers (RAB) such as:

- ◆ SRB at 2.5 kbit/s, 3.4 kbit/s and 13.6 kbit/s
- ◆ AMR at 12.2 kbit/s, 10.2 kbit/s, 7.95 kbit/s, 7.4 kbit/s, 6.7 kbit/s, 5.9 kbit/s, 5.15 kbit/s, 4.75 kbit/s (codec set A to H, M)
- ◆ RMC at 12.2 kbit/s, 64 kbit/s, 144 kbit/s, 384 kbit/s
- ◆ Asymmetric RMC at
 - 144 kbit/s DL/64 kbit/s UL
 - 384 kbit/s DL/64 kbit/s UL
 - 384 kbit/s DL/144 kbit/s UL

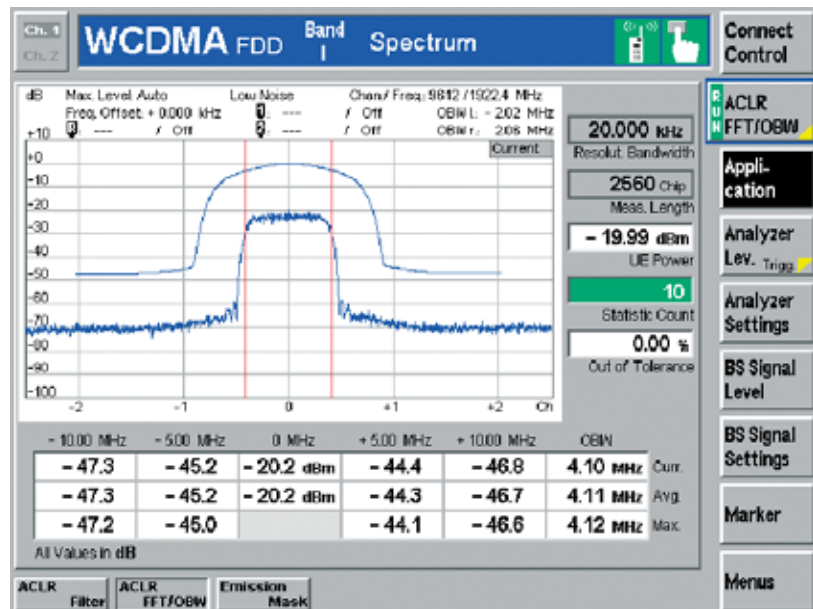

The ACLR menu shows all adjacent-channel-related information in graphical as well as in scalar numeric form. Since the ACLR FFT and OBW measurement methods are closely related, results for occupied bandwidth are displayed simultaneously. The scalar display excluding the center channel (0 MHz) may be switched to absolute readout as well.

An optional AMR speech codec for WCDMA that supports the above-listed data rates is also available. It allows audio measurements to be performed with the R&S® CMU200 audio board (option) or on an external audio analyzer, e.g. the R&S® UPL16.

The high flexibility of the signalling stack allows various parameters in the R&S® CMU200 MMI to be changed or different Node B configurations to be simulated via remote control.

WCDMA development

The well-structured, user-friendly menu design and the clear-cut screen layout provide quick access to all features and ensures trouble-free monitoring of the DUT (device under test). The tester can be switched between 3GPP and general QPSK modes to increase the usability with DUTs under development. For analy-

sis of the signalling messages between the UE and the R&S® CMU200, an optional message analyzer is available.

Quality assurance

Due to its high measurement repeatability and accuracy, the R&S® CMU200 is the right choice to help ensure a consistently high level of quality. WCDMA-specific measurements such as BER/BLER and EVM, plus the full implementation of complementary (i.e. ACLR and OBW) measurements provide an excellent test platform for high-quality products. Unrivalled AF/audio and RF/fading performance allows test setups at a low price and compact size with high test depth.

WCDMA highlights of the R&S® CMU200

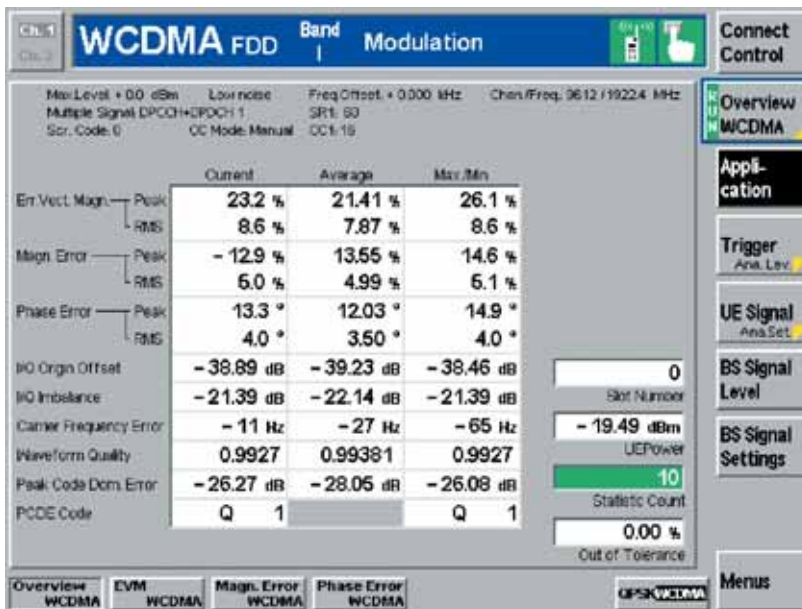

The modulation overview menu provides fast, comprehensive information on the UE's RF performance. The hotkeys at the bottom of the screen provide immediate access to specific and detailed measurements

Production of mobile phones

The production of mobile phones requires time-efficient and cost-effective measures that simultaneously ensure both high throughput and high yield. Owing to market-leading accuracy and to the unique IEC/IEEE bus concept of the R&S® CMU200, these two goals can be easily achieved in production environments.

Repair applications (manufacturing and service centers)

With its outstanding versatility, the R&S® CMU200 is also a suitable tool for mobile phone troubleshooting. Four configurable RF ports and a built-in RF connector switch matrix (standard unit) are provided to enable flexible signal level ranges and switching. Since each

R&S® CMU200 measurement menu allows an independent setting for the input and output ports, a phone fixture and spectrum analyzer probe can remain permanently connected to the R&S® CMU200.

Switching standards

Fast switching between 3GPP FDD and any of the other numerous standards supported by the R&S® CMU200 is part of the standard instrument and can be achieved by simply pressing a button or using a simple remote command.

Versatile production test layouts are possible and true multimode test bays that utilize the flexibility and throughput of the R&S® CMU200 are no longer a concept of the distant future.

Multimode UE applications are and will be further enhanced by suitable handover functions.

- ◆ Shortest measurement time ensuring high throughput
- ◆ Benchmark-breaking ICE/IEEE bus speed (see highlights of base unit)
- ◆ Combined measurements, many different measurement modes
- ◆ Multiband/multimode testing
- ◆ Powerful signalling capabilities available: MOC, MTC, MIR, NIR, inter-frequency handover, inter-RAT handover, cell reselection
- ◆ Display of UE properties
- ◆ Large selection of radio access bearers (RABs) with various data rates
- ◆ Up to 384 kbit/s reference measurement channels (symmetrical and asymmetrical)
- ◆ 3GPP-conforming generation of OCNS (orthogonal noise signals)
- ◆ Separate and highly accurate level setting for each individual DL code channel
- ◆ Simple voice test using RAB/echo by tester; dedicated audio tests available (option)
- ◆ User-defined settings of RF-relevant signalling parameters
- ◆ 3G dedicated trigger options
- ◆ External message analyzer for reading signalling message log files (option)
- ◆ Simple interactive operation in manual MMI
- ◆ No specialized network knowledge required
- ◆ Stimulation of compressed mode patterns soon available
- ◆ Compressed mode measurements soon available

Bluetooth® measurements in the R&S® CMU200

General

The R&S® CMU200 was the first *Bluetooth* test set on the market. It is the only radio-communication tester worldwide to offer Bluetooth as well as all important mobile radio standards in a single instrument.

Applications

The R&S® CMU200 with the *Bluetooth* option is the ideal instrument for the production, development and maintenance of any kind of device with an integrated *Bluetooth* interface.

Due to its modular platform concept, the R&S® CMU200 is the ideal solution for all cellular-standard mobile-phone production lines.

Parallel operation for high measurement speed

Due to the high measurement speed and large memory capacity of the R&S® CMU200, transmitter and receiver measurements can be carried out simultaneously. When measurements are performed in frequency hopping mode, a significant test depth is rapidly attained. Only a few seconds are required between call setup, transmitter and receiver measurements and call detach. Fast test cycles ensure a fast return on investment.

Many convenient measurement functions

The R&S® CMU200 offers a large number of statistical monitoring and measurement functions. It is possible, for instance, to define individual tolerances for each measured value and to stop a measurement sequence after a certain

number of measurements or when a tolerance has been exceeded. Besides the common traces for power and modulation versus time, averaged minimum or maximum traces can also be displayed over a user-defined number of packets.

Signalling

Setting up a *Bluetooth* connection

The R&S® CMU200 acts as the master of a *Bluetooth* piconet, the DUT as a slave. The R&S® CMU200 is able to perform the inquiry procedure for the identification of all *Bluetooth* devices within range of the R&S® CMU200. All devices found are listed on the display and one of them can be selected for the paging procedure. The R&S® CMU200 then establishes the connection to the DUT and switches it to test mode operation.

The inquiry procedure can be skipped if the *Bluetooth* device address of the DUT is already known. In this case, a shorter setup time for the connection can be achieved. This is important for production tests of *Bluetooth* devices to increase the maximum throughput of a production line. According to the *Bluetooth* test mode specification, the DUT has to be locally enabled for test mode operation.

After a *Bluetooth* link is established, the R&S® CMU200 sends commands to the DUT to switch it to the desired test mode. The R&S® CMU200 is then able to perform a number of transmitter and receiver measurements.

The R&S® CMU200 is also capable of setting up a normal *Bluetooth* asynchronous connectionless (ACL) link without activating the test mode. Via this normal link, the power and frequency accuracy of every DUT can be measured, regardless

of whether the DUT has been locally enabled for the test mode.

If a normal (ACL) link is used, the R&S® CMU200 can switch the DUT to the audio, hold, park and sniff modes.

Audio mode

In the audio mode, the R&S® CMU200 establishes a synchronous connection-oriented (SCO) link to the DUT in addition to the ACL link. The R&S® CMU200's built-in *Bluetooth* audio codec supports CVSD as well as A-law and μ -law coding. External audio generators and analyzers can be connected by means of one analog input and output each on the R&S® CMU200 front panel. A much more convenient alternative is the R&S® CMU-B41 audio option. This option, in conjunction with the *Bluetooth* audio codec, makes it very easy to carry out basic audio measurements on *Bluetooth* DUTs.

Park, hold and sniff modes

The power consumption of a *Bluetooth* chipset is considerably reduced in these three modes, making them particularly important in all battery-powered *Bluetooth* devices. The R&S® CMU200 can switch the DUT to the park, hold or sniff mode, making it possible to check the reduced power consumption by means of external test equipment.

Signalling information from the DUT

The R&S® CMU200 is able to display a variety of information that is received from the DUT (e.g. device name, version numbers, service class, supported features).

Compliance with existing Bluetooth standards

The R&S®CMU200 is compliant with the *Bluetooth* Core Specifications Version 1.1. The *Bluetooth* test mode (Core Spec. Part I:1) is implemented with all commands needed to perform the TX/RX measurements. In addition, the R&S®CMU200 is capable of testing all DUTs that support the new *Bluetooth* Core Specifications Version 1.2, since the test mode specified in the new version does not include any changes relevant to the R&S®CMU200.

The *Bluetooth* RF Test Specification Version 0.92 describes RF test cases for the *Bluetooth* qualification process.

Rohde&Schwarz offers the Test System R&S®TS8960 for *Bluetooth* qualification tests, which is fully compliant with the RF test specification. Although the R&S®CMU200 was not designed for qualification tests, the RF test specification was taken as a guideline for the implementation of the R&S®CMU200's *Bluetooth* measurements. All TX measurements are implemented according to the test specification Version 0.92.

The Connection Control menu allows the DUT to be inquired and paged. After link setup, the R&S®CMU200 can switch the DUT to one of five submodes.

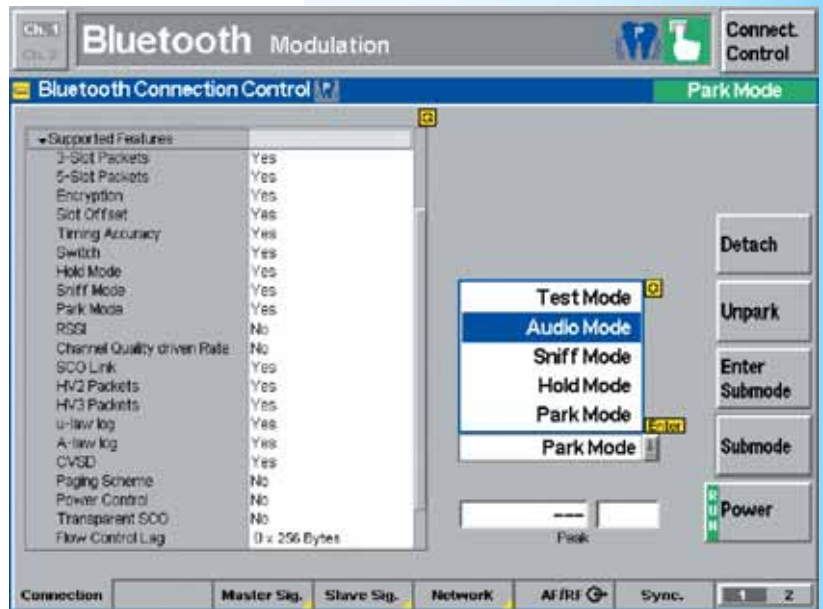

The Power menu shows the results in graphical and scalar form. Statistical functions as well as convenient markers facilitate further evaluation. The DUT power can be varied in stages using the up and down keys.

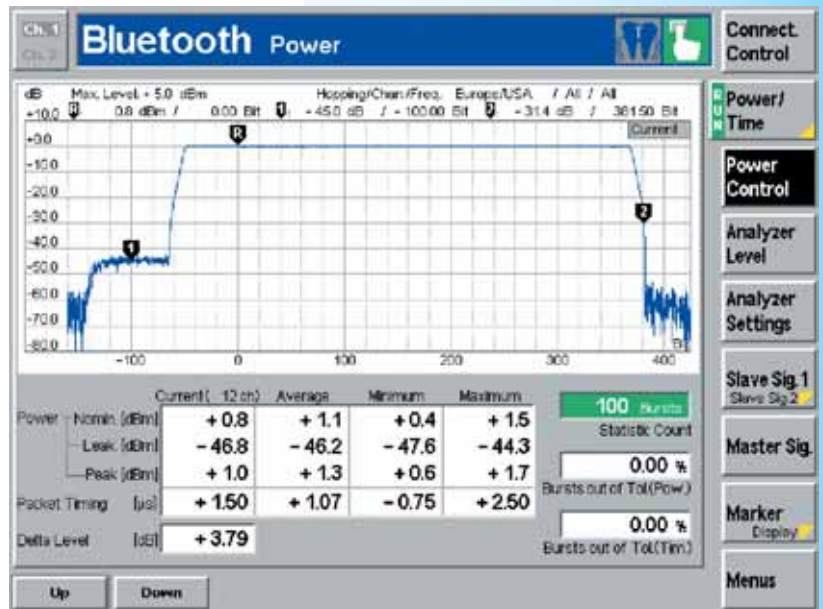

The graphical display of modulation results may be spread between 1/1 and 1/16 of a burst for in-depth analysis. The "Max. Freq. Dev." and "Min. Freq. Dev." results allow the highest and lowest values of a payload to be evaluated individually.

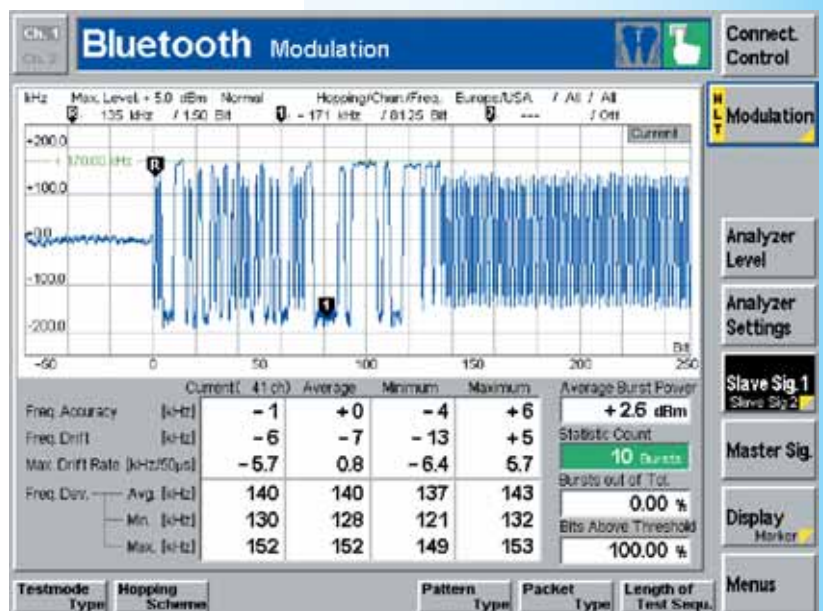

Bluetooth wireless technology in the R&S®CMU200

TX measurements

The current measurement values for each parameter are displayed on the R&S®CMU200 screen. Additionally, average, maximum and minimum values are displayed as a result of a statistical evaluation of a definable number of *Bluetooth* packets (bursts).

Power measurements (output power)

Measurement parameters:

- ◆ Nominal power (measured as the part of the burst starting at the detected first bit of the preamble (bit 0) to the last bit of the burst)
- ◆ Peak power (shows the highest power level within a burst)
- ◆ Leakage power (measured within defined areas before and after the burst)

Power control

The Power menu enables the power control function of a *Bluetooth* DUT to be checked. In this mode, the R&S®CMU200 can send the "Power up" and "Power down" commands to the DUT. The user has two keys for manual power control. After each keystroke, the R&S®CMU200 displays in a measurement window the difference level as compared to each previous power level. In compliance with the *Bluetooth* specifications, all difference values must be in the 2 dB to 8 dB range. When the maximum or minimum power level is reached, the DUT sends a message which is displayed on the R&S®CMU200.

Timing measurements (packet timing error)

Measurement parameter:

- ◆ Packet alignment (distance between ideal master receiver slot and detected bit 0 of the received burst)

This measurement is displayed on the Power screen.



The DUT can be connected to the R&S®CMU200 via an RF coupler (antenna) or a cable.

Modulation measurements (modulation characteristics/quality)

Measurement parameters:

- ◆ Frequency accuracy/initial carrier frequency tolerance (ICFT) (difference between measured frequency and intended transmitted frequency, measured in the preamble at the beginning of a packet)
- ◆ Carrier frequency drift (difference between the frequency at the start of the packet and the frequency in the payload)
- ◆ Maximum drift rate (maximum drift rate anywhere within the packet payload)
- ◆ Average, maximum and minimum frequency deviation (calculated over the packet payload)

In compliance with the *Bluetooth* RF test specifications, a minimum of 99.9 % of all measured bits must have a frequency deviation of at least 115 kHz. The R&S®CMU200 shows the measurement results in an additional window in the modulation display.

RX measurements

For RX measurements, the built-in signal generator generates a selectable bit sequence, which is looped back in the DUT and demodulated and processed by the R&S®CMU200 again. The TX level of the R&S®CMU200 can be adjusted for this measurement. The BER application allows up to five test programs to be defined. Each program can independently set values such as control parameters, limits, repetition or statistical cycles.

Sensitivity (single slot packets/multi-slot packets)

Measurement parameters:

- ◆ BER (percentage of bit errors that have occurred within the current statistical cycle)
- ◆ BER search function (sensitivity level for a predefined BER level)
- ◆ PER (percentage of packet errors that have occurred within the current statistical cycle)

Bluetooth wireless technology highlights of the R&S®CMU200

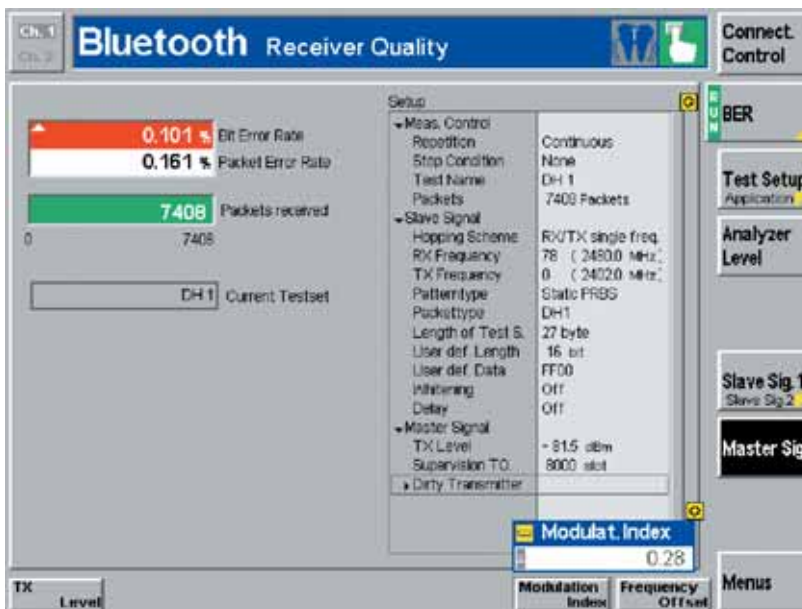

The receiver quality measurement includes the output of BER and PER values. It supports three modes, i.e. single shot, continuous and search of a target BER value, by automatic variation of the R&S®CMU200 output level. The modulation index and the frequency offset of the R&S®CMU200 transmitter signal can be set in any combination ("dirty signal").

Definable dirty transmitter parameters

The *Bluetooth* RF test specifications stipulate a "dirty transmitter" for measuring receiver sensitivity. Its two main parameters, i.e. modulation index and frequency offset, can be continuously adjusted on the R&S®CMU200 and set in any combination. The R&S®CMU200 can use dirty transmitter settings even during link setup (query, connect), thus enabling a wide variety of tests that far exceed test specification requirements.

Control commands to the DUT

The R&S®CMU200 can send control commands with user-specific contents to the DUT via the normal ACL link. This application, which is very useful in production, allows the control of specific DUT functions via the RF interface, e.g. switching a headset LED on and off.

Channel display in frequency-hopping mode

The R&S®CMU200 enables the convenient determination of all RF channels in which the DUT exceeds specified tolerances. If "on limit failure" is set as a stop condition in frequency-hopping measurements, the R&S®CMU200 automatically stops the measurement when a measured value exceeds the definable limit values. The R&S®CMU200 in addition displays the number of the channel in which the out-of-tolerance condition occurred – a very helpful function for laboratory measurements.

Measurements without link setup

Many *Bluetooth* DUTs can be locally switched to the transmitter test mode via the HCI interface. The R&S®CMU200 can carry out power, frequency and modulation measurements on such DUTs without previously establishing a *Bluetooth* link.

- ◆ Measurements in *Bluetooth* test mode, non-test mode or without a connection
- ◆ Selectable channels and stop conditions for in-depth signal analysis
- ◆ Park, hold and sniff modes for power consumption tests
- ◆ Audio codec integrated (CVSD, A-law, μ -law) for test of audio equipment
- ◆ High measurement accuracy and speed
- ◆ Parallel TX and RX measurement of the RF interface in loopback mode
- ◆ Output of *Bluetooth*-specific clock signal
- ◆ IF signal output

Supported standards

- ◆ *Bluetooth* Core Specifications Version 1.1 (DUTs to 1.2 can also be measured)
- ◆ RF Test Specification Version 0.92

The *Bluetooth* word mark and logos are owned by the *Bluetooth* SIG, Inc. and any use of such marks by Rohde&Schwarz is under license.

I/Q and IF interfaces for the R&S® CMU 200

Functionality

The R&S® CMU-B17 option allows access to analog I/Q and IF signals in both communication directions (uplink and downlink). Once a radio link has been established, complex I/Q signals can be applied or transmitted for further analysis. This solution will allow the R&S® CMU 200 to be used for new tasks in the development and testing of mobile phones and their modules.

Technical concept

The selectable I/Q and IF interface module is looped between the RF module (modulator, demodulator) and the digital module (test DSP, signalling unit) of the R&S® CMU 200. During normal operation without access to I/Q or IF signals, the interface module can be set to the bypass mode. This eliminates any further influence on the transmit and receive signal, and the original data of the instrument is retained. In addition to preconfigured default settings for constantly recurring T&M tasks (e.g. fading of the transmit signal), all types of customized signal path combinations can be set.

Receiver tests under fading conditions

A fading simulator is used to test the receiver characteristics of mobile phones under practical conditions. An RF channel that is ideal if the tester and the DUT are connected by means of a cable is provided with fading effects that also occur under real field conditions.

Fitted with the R&S® CMU-B17 option, the R&S® CMU 200, together with the Fading Simulator R&S® ABFS, provides a cost-effective solution for the specified measurement task. Optionally, the Signal Generator R&S® SMIQ with the option R&S® SMIQB14 can be used; the transmit module of the generator can also provide a faded RF signal.

Testing of mobile radio modules

Another major application is the generation and analysis of I/Q signals. Most mobile radio modules include an RF module and a baseband module that communicate with each other via an analog I/Q interface. The I/Q and IF interface can now be used to access the RF modules from both sides.

Quite often, different teams in development departments are responsible for the RF and the baseband modules. Testing via the I/Q interfaces allows space- and time-independent development.

I/Q signal analysis

If I/Q signals are applied to the receive path of the R&S® CMU 200, they can be analyzed analogously to the RF signals. In addition to more complex modulation parameters (error vector magnitude (EVM), peak code domain error power), direct I/Q parameters such as I/Q offset or I/Q imbalance can be analyzed.

Your local Rohde & Schwarz representative will gladly provide you with further information about the R&S® CMU-B17 option.

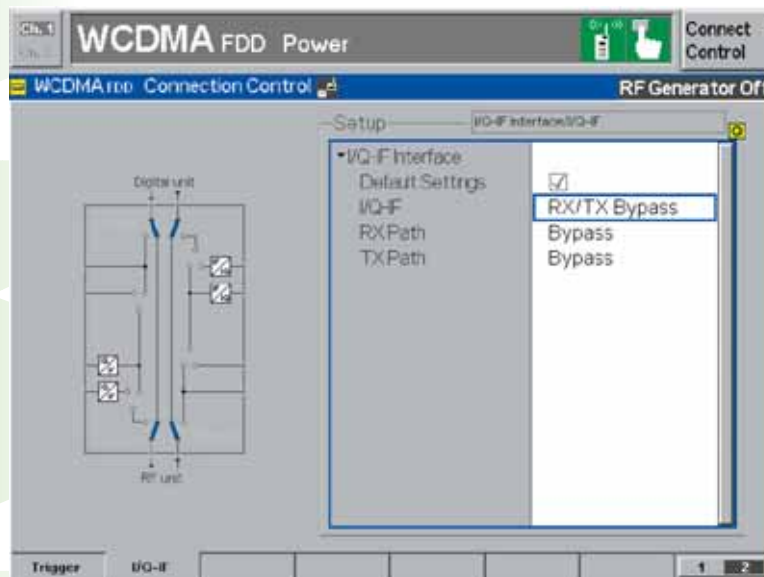

Menu in the R&S® CMU 200 for setting the test paths (default setting: RX/TX bypass mode).

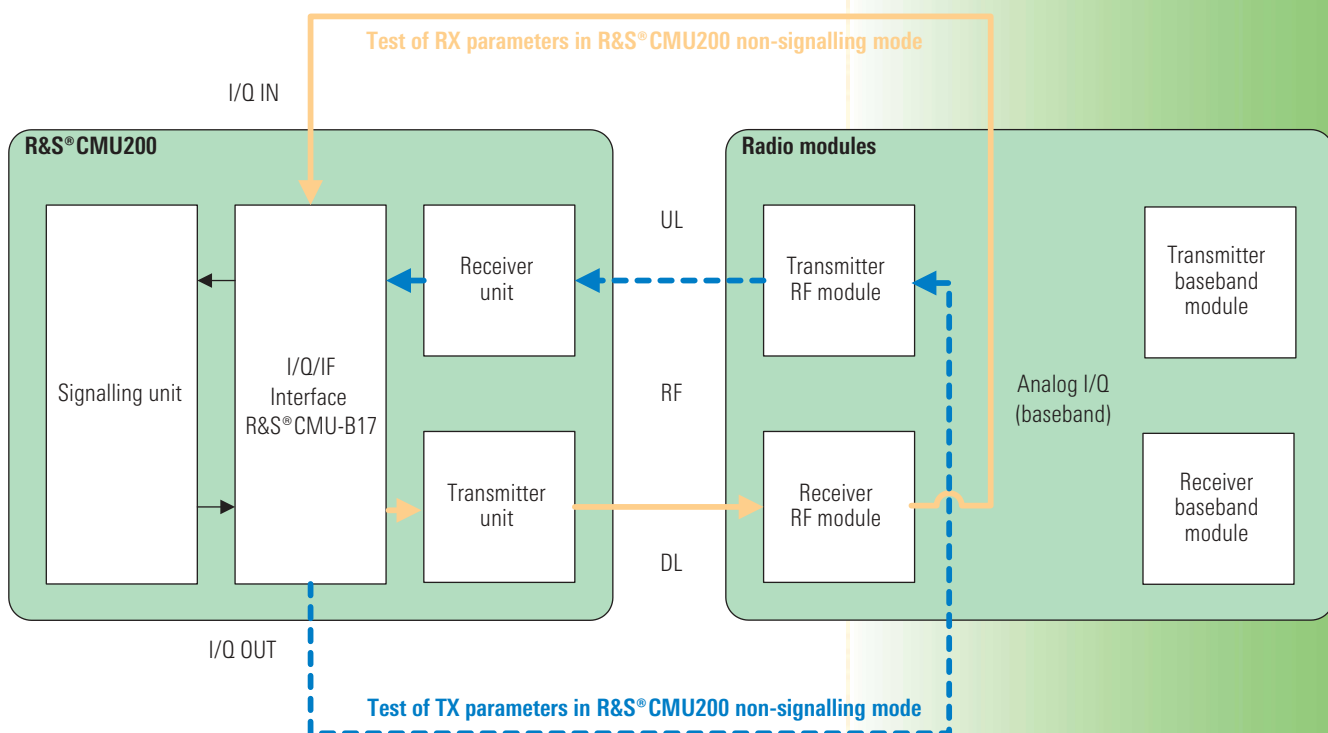
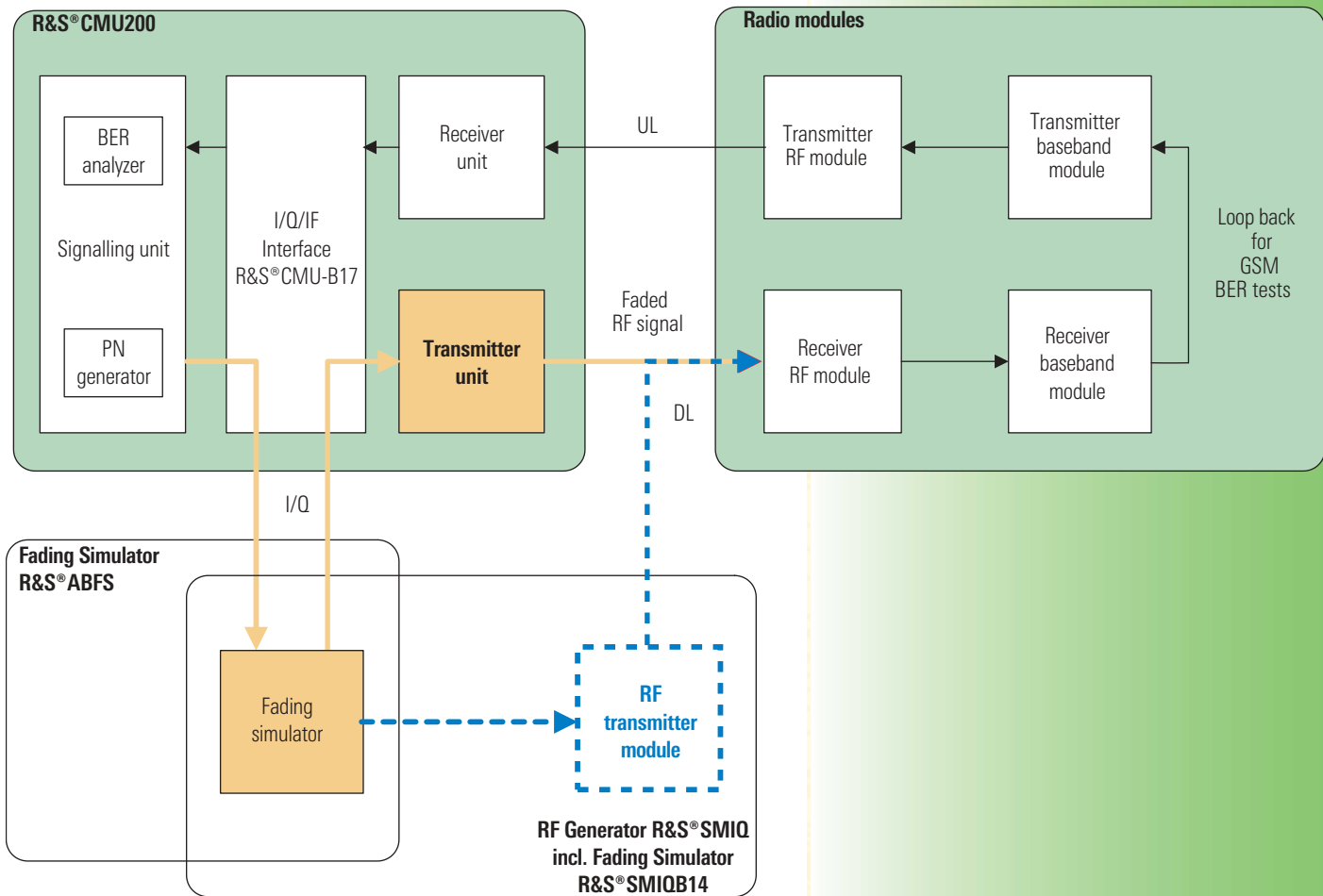

R&S® CMU200 options and accessories

Ordering information

Type	Description	GSM/GPRS/ EDGE/HSCSD	TDMA	AMPS	cdma2000	WCDMA	Bluetooth	Order No.
R&S® CMU200	Base unit with following accessories: power cord, operating manual, service manual for instrument	✓	✓	✓	✓	✓	✓	1100.0008.02
R&S® CMU-B11¹⁾	Reference OCXO, aging 2×10^{-7} /year; ensures high absolute accuracy, minimum temperature-dependent drift and especially high long-term stability; used for measurements with exact frequency stability requirements	☺	☺	☺	☺	☺	☺	1100.5000.02
R&S® CMU-B12¹⁾	High-stability OCXO, aging 3.5×10^{-8} /year. Oven crystal with highest long-term stability; ensures compliance with tolerances specified by GSM; used for highly demanding frequency stability requirements to GSM 11.20	☺	☺	☺	☺	☺	☺	1100.5100.02
R&S® CMU-B17	Analog I/Q IF interface	☺	☺	–	☺	☺	–	1100.6906.02
R&S® CMU-B21	Universal signalling unit; provides multistandard signalling hardware; required for WCDMA 3GPP FDD	✓	✓	✓	–	✓	✓	1100.5200.14
R&S® CMU-B41	Audio generator and analyzer; includes audio frequency (AF) generator, voltmeter, distortion meter	☺	☺	✓	☺	☺	☺	1100.5300.02
R&S® CMU-B52	Internal versatile multimode speech coder/decoder; R&S® CMU-B21 necessary	☺	☺	–	–	☺	☺	1100.5400.14
R&S® CMU-B53	Bluetooth extension; R&S® CMU-B21 necessary	–	–	–	–	–	✓	1100.5700.14
R&S® CMU-B54	Signalling module for AMPS, TDMA, GSM/GPRS/EGPRS; R&S® CMU-B21 necessary	☺	☺	☺	–	–	–	1150.2604.14
R&S® CMU-B56	WCDMA (3GPP FDD) signalling module; R&S® CMU-B21 necessary	–	–	–	–	✓	–	1150.1850.14
R&S® CMU-B66²⁾	Versatile baseband board for WCDMA (3GPP FDD) Layer 1, DL, non-signalling	–	–	–	–	✓	–	1149.9509.02
R&S® CMU-B68²⁾	Versatile baseband board for WCDMA (3GPP FDD) Layer 1, DL and UL, non-signalling	–	–	–	–	✓	–	1149.9809.02
R&S® CMU-B69	Option package WCDMA (3GPP/FDD) complete for band 1, signalling	–	–	–	–	✓	–	1150.2304.02
R&S® CMU-B73	Analog telephone line interface	–	–	☺	–	–	–	1150.2004.02
R&S® CMU-B83	cdma2000 1x signalling unit	–	–	–	✓	–	–	1150.0301.12
R&S® CMU-B85	8k/13k QCELP, 8k EVRC speech codec for cdma2000 1x Signalling Unit R&S® CMU-B83	–	–	–	☺	–	–	1100.7002.12
R&S® CMU-B87	Message monitor for cdma2000 1x Signalling Unit R&S® CMU-B83	–	–	–	☺	–	–	1150.2404.02
R&S® CMU-B88	cdma2000 1xEV-DO (HDR) extension board for cdma2000 1x Signalling Unit R&S® CMU-B83	–	–	–	☺	–	–	1158.9908.02
R&S® CMU-B95	2nd TX RF channel; BCCH always present with GSM/GPRS/EGPRS	☺	–	–	–	–	–	1159.0504.02
R&S® CMU-B99	RF1 level range identical to RF2	☺	☺	☺	☺	☺	☺	1150.1250.02
R&S® CMU-U65	3G measurement DSP and performance accelerator	–	–	–	✓	✓	–	1100.7402.04
R&S® CMU-U80	Trigger output connector for gpsOne	–	–	–	☺	–	–	1150.1750.02
R&S® CMU-K20	GSM400 mobile station signalling/non-signalling test software	✓	–	–	–	–	–	1115.5900.02
R&S® CMU-K21	GSM900, R-GSM and E-GSM mobile station signalling/non-signalling test software	✓	–	–	–	–	–	1115.6007.02
R&S® CMU-K22	GSM1800 (DCS) mobile station signalling/non-signalling test software	✓	–	–	–	–	–	1115.6107.02
R&S® CMU-K23	GSM1900 (PCS) mobile station signalling/non-signalling test software	✓	–	–	–	–	–	1115.6207.02
R&S® CMU-K24	GSM850 mobile station signalling/non-signalling test software	✓	–	–	–	–	–	1115.6307.02
R&S® CMU-K27	IS-136/cellular (800 MHz band) mobile station signalling/non-signalling test software	–	✓	–	–	–	–	1115.6607.02
R&S® CMU-K28	IS-136/PCS (1900 MHz band) mobile station signalling/non-signalling test software	–	✓	–	–	–	–	1115.6707.02
R&S® CMU-K29	AMPS mobile station signalling/non-signalling test software	–	–	✓	–	–	–	1115.6807.02
R&S® CMU-K42	GPRS test software extension for all GSM test software packages	☺	–	–	–	–	–	1115.4691.02
R&S® CMU-K43	EGPRS classic (EDGE) signalling test software for all GSM test software packages	☺	–	–	–	–	–	1115.6907.02
R&S® CMU-K45	AMR test software extension for all GSM software packages	☺	–	–	–	–	–	1150.3100.02
R&S® CMU-K53	Bluetooth test software; R&S® CMU-B53 necessary	–	–	–	–	–	✓	1115.5000.02
R&S® CMU-K65³⁾	WCDMA (3GPP/FDD) UL user equipment TX test, non-signalling test software	–	–	–	–	✓	–	1115.4891.02
R&S® CMU-K66³⁾	WCDMA (3GPP/FDD) DL generator, non-signalling test software; R&S® CMU-U66 or R&S® CMU-B66 necessary	–	–	–	–	✓	–	1115.5100.02
R&S® CMU-K67	WCDMA (3GPP FDD) band 3, UE test signalling software; R&S® CMU-K65 and R&S® CMU-K66 necessary	–	–	–	–	✓	–	1150.3000.02
R&S® CMU-K68	WCDMA (3GPP FDD) band 1, UE test signalling software; R&S® CMU-K65 and R&S® CMU-K66 necessary	–	–	–	–	✓	–	1115.5300.02

Type	Description	GSM/GPRS/ EDGE/HSCSD	TDMA	AMPS	cdma2000	WCDMA	Bluetooth	Order No.
R&S®CMU-K69	WCDMA (3GPP FDD) band 2, UE test signalling software; R&S®CMU-K65 and R&S®CMU-K66 necessary	–	–	–	–	✓	–	1115.5400.02
R&S®CMU-K83	cdma2000 1x (450 MHz band) mobile station signalling/non-signalling test software	–	–	–	✓	–	–	1150.3500.02
R&S®CMU-K84	cdma2000 1x (cellular band) mobile station signalling/non-signalling test software	–	–	–	✓	–	–	1150.3600.02
R&S®CMU-K85	cdma2000 1x (PCS band) mobile station signalling/non-signalling test software	–	–	–	✓	–	–	1150.3700.02
R&S®CMU-K86	cdma2000 1x (IMT2000 band) mobile station signalling/non-signalling test software	–	–	–	✓	–	–	1150.3800.02
R&S®CMU-K88	cdma2000 1xEV-DO (HDR) test software; R&S®CMU-B88 necessary	–	–	–	☺	–	–	1150.3900.02
R&S®CMU-DCV	Documentation of calibration values	☺	☺	☺	☺	☺	☺	0240.2193.08
R&S®CRT-Z2	GSM900/DCS1800 GSM/GPRS test SIM for loopback mode, required for BER and other applications	☺	–	–	–	–	–	1039.9005.02
R&S®CRT-Z3	3G UICC/USIM test card for UMTS	–	–	–	–	☺	–	1139.1005.02
R&S®CRT-Z12	GSM850/PCS1900 GSM/GPRS test SIM for loopback mode, required for BER and other applications	☺	–	–	–	–	–	1139.1205.02
R&S®CMU-Z1	256 Mbyte memory card for use with PCMCIA interface; flash ATA formatted, also named PC Card ATA	☺	☺	☺	☺	☺	☺	1100.7490.04
R&S®CMU-Z6	Enhancement of wideband modulation (WCDMA 3GPP FDD) analyzer accuracy	–	–	–	–	☺	–	1150.0001.02
R&S®CMU-Z10	Antenna coupler 900 MHz/1700 MHz to 2200 MHz	☺	☺	☺	☺	☺	☺	1150.0801.02
R&S®CMU-Z11	RF shielded cover for R&S®CMU-Z10	☺	☺	☺	☺	☺	☺	1150.1008.02
R&S®CMU-Z12	Bluetooth antenna extension for R&S®CMU-Z10	–	–	–	–	–	☺	1150.1043.02
R&S®CMU-Z13	USB feed through for R&S®CMU-Z10	☺	☺	☺	☺	☺	☺	1159.1200.02
R&S®CMU-Z46	WCDMA (3GPP FDD) message analyzer and recorder	–	–	–	–	☺	–	1159.0804.02
R&S®CMU-Z49	GSM message viewer	☺	–	–	–	–	–	1150.2704.02
R&S®CMU-Z50	Handset for R&S®CMU200	☺	☺	☺	☺	☺	☺	1159.0104.02
R&S®ZZA-411	19" rack adapter	☺	☺	☺	☺	☺	☺	1096.3283.00

¹⁾ R&S®CMU-B11 or R&S®CMU-B12 possible. One of two OCOs should be installed to ensure high frequency accuracy, or an external frequency reference may be used, if available.

²⁾ For new units only. Factory installation only.

³⁾ R&S®CMU-U65 necessary.

Definition of table symbols:

✓ mandatory; ☺ optional; – not applicable

For specifications see PD 0758.0039.22
and www.rohde-schwarz.com
(search term: CMU200)



ROHDE&SCHWARZ

www.rohde-schwarz.com

R&S® is a registered trademark of Rohde&Schwarz GmbH&Co. KG · Trade names are trademarks of the owners · Printed in Germany · (Pe as)
PD 0758.0039.12 · Universal Radio Communication Tester R&S® CMU200 · Version 06.00 · May 2004 · Data without tolerance limits is not binding · Subject to change

Value-added services

- ◆ Rohde&Schwarz offers a wide range of training programs not only on products but also on new technical developments
- ◆ Rohde&Schwarz application engineers help to optimize the use of the R&S® CMU 200 and the overall performance of your local environment
- ◆ Over 70 representative offices and a worldwide network of service and calibration centers ensure Rohde&Schwarz support where you need it

Quality management at Rohde & Schwarz

Lasting customer satisfaction is our primary objective. The quality management system of Rohde&Schwarz meets the requirements of ISO 9001 and encompasses virtually all fields of activity of the company.



Basics

Technology

Solutions

GSM **GPRS**
HSCSD
EDGE

TDMA

AMPS

1xEV-DO

cdma2000

WCDMA

Bluetooth

Interfaces



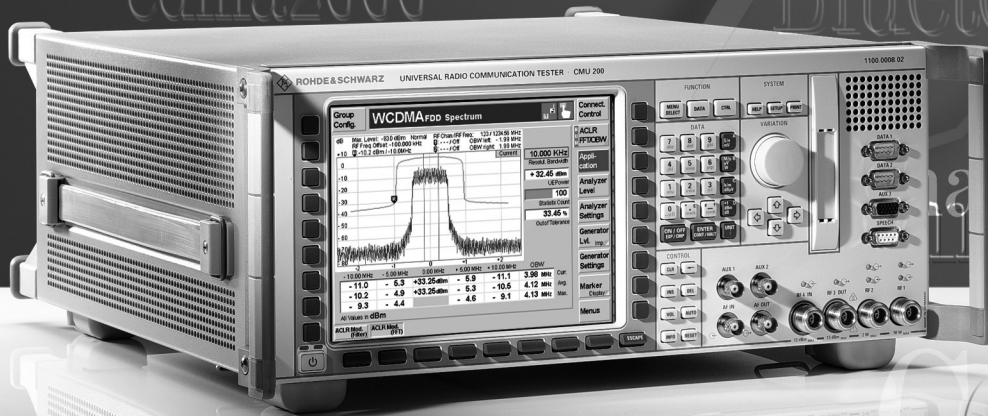

Universal Radio Communication Tester R&S®CMU200

Specifications

Version
06.00

May
2004



ROHDE & SCHWARZ

CONTENTS

BASE UNIT SPECIFICATIONS	4
TIMEBASE TCXO	4
TIMEBASE OCXO – OPTION R&S CMU-B11	4
TIMEBASE OCXO – OPTION R&S CMU-B12	4
REFERENCE FREQUENCY INPUTS/OUTPUTS.....	4
RF GENERATOR.....	5
RF ANALYZER.....	6
<i>Power meter (wideband)</i>	7
<i>Power meter (frequency-selective)</i>	7
SPECTRUM ANALYZER.....	8
GENERAL SPECIFICATIONS	9
INPUTS AND OUTPUTS (REAR PANEL)	10
GSM SPECIFICATIONS – MOBILE STATION TEST	11
RF GENERATOR.....	11
OPTION ADDITIONAL RF GENERATOR R&S CMU-B95.....	12
RF ANALYZER	12
<i>Power meter (frequency-selective)</i>	12
<i>Modulation analysis</i>	13
<i>Burst power measurement</i>	13
<i>Spectrum due to modulation</i>	14
<i>Spectrum due to switching</i>	14
OPTION SPEECH CODEC R&S CMU-B52	14
TDMA SPECIFICATIONS – MOBILE STATION TEST	15
RF GENERATOR.....	15
RF ANALYZER.....	15
<i>Modulation analysis</i>	15
<i>Power meter (frequency-selective)</i>	16
<i>Power versus time measurement</i>	16
<i>Adjacent channel power measurement</i>	16
AMPS SPECIFICATIONS – MOBILE STATION TEST	17
RF GENERATOR.....	17
RF ANALYZER.....	17
<i>Power meter (frequency-selective)</i>	18
<i>FM measurement</i>	18
AF GENERATOR.....	18
AF ANALYZER	18
CDMA2000 SPECIFICATIONS – MOBILE STATION TEST	19
RF GENERATOR.....	19
RF ANALYZER.....	20
<i>Power meter (frequency-selective)</i>	20
<i>Modulation analyzer</i>	20
OPTION SPEECH CODEC R&S CMU-B85	21
1XEV-DO SPECIFICATIONS – ACCESS TERMINAL TEST	22
RF GENERATOR.....	22
RF ANALYZER.....	23
<i>Power meter (frequency-selective)</i>	23
<i>Modulation analyzer</i>	23

WCDMA SPECIFICATIONS – MOBILE STATION (UE) TEST	24
RF GENERATOR.....	24
RF ANALYZER (TX MEASUREMENTS)	25
<i>Modulation analysis</i>	26
<i>Spectrum measurements</i>	27
<i>Power meter (frequency-selective)</i>	28
<i>Code domain power</i>	29
<i>Receiver quality (bit error rate measurements)</i>	29
OPTION SPEECH CODEC R&S CMU-B52	29
BLUETOOTH SPECIFICATIONS.....	30
RF GENERATOR.....	30
RF ANALYZER	31
<i>Power meter (frequency-selective) and power versus time</i>	31
<i>Modulation analyzer</i>	31
<i>Timing measurement</i>	32
SPEECH CODEC	32
OPTION I/Q/IF INTERFACE R&S CMU-B17	33
I/Q INTERFACE.....	33
INFLUENCE ON RF INTERFACE	33
IF INTERFACE	34
REMARKS	35
OPTION AUDIO GENERATOR/ANALYZER R&S CMU-B41	36
AF GENERATOR	36
AF ANALYZER	36
OPTION RF1 LEVEL RANGE IDENTICAL TO RF2 R&S CMU-U99/B99.....	36

The specifications for the R&S CMU200 (Order No. 1100.0008.02) refer to a fully equipped unit with all options installed.

Base unit specifications

Timebase TCXO

Max. frequency drift	in temperature range +5 °C to +45 °C	$\pm 1 \times 10^{-6}$
Max. aging		$\pm 1 \times 10^{-6}$ /year

Timebase OCXO – option R&S CMU-B11

Max. frequency drift	in temperature range +5 °C to +45 °C	$\pm 1 \times 10^{-7}$
Max. aging	after 30 days of operation	$\pm 2 \times 10^{-7}$ /year $\pm 5 \times 10^{-9}$ /day
Warmup time	at +25 °C	approx. 5 min

Timebase OCXO – option R&S CMU-B12

Max. frequency drift		
	in temperature range +5°C to +45 °C, referred to +25 °C	$\pm 5 \times 10^{-9}$
	with instrument orientation	$\pm 3 \times 10^{-9}$
	referred to turn-off frequency after 2 h warmup time following a 24 h off time at +25 °C	$\pm 5 \times 10^{-9}$
Max. aging	after 30 days of operation	$\pm 3.5 \times 10^{-8}$ /year $\pm 5 \times 10^{-10}$ /day
Warmup time	at +25 °C	approx. 10 min

Reference frequency inputs/outputs

Synchronization input		BNC connector REF IN
Frequency	sinewave squarewave (TTL level)	1 MHz to 52 MHz, step 1 kHz 10 kHz to 52 MHz, step 1 kHz
Max. frequency variation		$\pm 5 \times 10^{-6}$
Input voltage range		0.5 V to 2 V, rms
Impedance		50 Ω

Synchronization output 1		BNC connector REF OUT 1
Frequency		10 MHz from internal reference or frequency at synchronization input
Output voltage		>1.4 V, peak-peak
Impedance		50 Ω

Synchronization output 2		BNC connector REF OUT 2
Frequency		net-specific frequencies in range 100 kHz to 40 MHz
Output voltage	$f \leq 13$ MHz	>1.0 V, peak-peak
Impedance		50 Ω

RF generator

Frequency range		100 kHz to 2700 MHz
Frequency resolution		0.1 Hz
Frequency uncertainty		same as timebase + frequency resolution
Frequency settling time		<400 μ s to $\Delta f < 1$ kHz

Output level range		
RF 1	100 kHz to 2200 MHz 2200 MHz to 2700 MHz	-130 dBm to -27 dBm -130 dBm to -33 dBm
RF 2	100 kHz to 2200 MHz 2200 MHz to 2700 MHz	-130 dBm to -10 dBm -130 dBm to -16 dBm
RF 3 OUT	100 kHz to 2200 MHz 2200 MHz to 2700 MHz	-90 dBm to +13 dBm -90 dBm to +5 dBm

Output level uncertainty	in temperature range +20 °C to +35 °C	
RF 1, RF 2	output level ≥ -106 dBm 10 MHz to 450 MHz 450 MHz to 2200 MHz 2200 MHz to 2700 MHz output level > -117 dBm 450 MHz to 2200 MHz 2200 MHz to 2700 MHz output level -117 dBm to -130 dBm 450 MHz to 2200 MHz 2200 MHz to 2700 MHz	<0.6 dB <0.6 dB <0.8 dB <0.6 dB ¹ <0.8 dB ¹ <1.5 dB ^{1,2} <1.5 dB ^{1,2}
RF 3 OUT	10 MHz to 450 MHz output level -80 dBm to +10 dBm 450 MHz to 2200 MHz output level -90 dBm to +10 dBm 2200 MHz to 2700 MHz output level -90 dBm to +5 dBm	<0.8 dB <0.8 dB <1.0 dB

Output level uncertainty	in temperature range +5 °C to +45 °C	
RF 1, RF 2	output level ≥ -106 dBm 10 MHz to 450 MHz 450 MHz to 2200 MHz 2200 MHz to 2700 MHz output level > -117 dBm 450 MHz to 2200 MHz 2200 MHz to 2700 MHz output level -117 dBm to -130 dBm 450 MHz to 2200 MHz 2200 MHz to 2700 MHz	<1.0 dB <1.0 dB <1.5 dB <1.0 dB ¹ <1.5 dB ¹ <1.5 dB ^{1,2} <1.5 dB ^{1,2}
RF 3 OUT	10 MHz to 450 MHz output level -80 dBm to +10 dBm 450 MHz to 2200 MHz output level -90 dBm to +10 dBm 2200 MHz to 2700 MHz output level -90 dBm to +5 dBm	<1.0 dB <1.0 dB <1.5 dB

Output level settling time		<4 μ s
-----------------------------------	--	------------

Output level resolution		0.1 dB
--------------------------------	--	--------

Generator RF level repeatability	typical values after 1 h warmup time output level ≥ -80 dBm output level < -80 dBm	<0.01 dB <0.1 dB
---	---	---------------------

¹ Not valid at frequencies of net-clock harmonics.

² Valid for RF1 only.

VSWR		
RF 1	10 MHz to 2000 MHz 2000 MHz to 2200 MHz 2200 MHz to 2700 MHz	<1.2 <1.3 <1.6
RF 2	10 MHz to 2200 MHz 2200 MHz to 2700 MHz	<1.2 <1.6
RF 3 OUT	10 MHz to 2200 MHz 2200 MHz to 2700 MHz	<1.5 <1.7

Attenuation of harmonics	up to 7 GHz	
RF 1, RF 2	$f_0 = 10 \text{ MHz to } 200 \text{ MHz}$	>20 dB
RF 1, RF 2	$f_0 = 200 \text{ MHz to } 2200 \text{ MHz}$	>30 dB
RF 3 OUT	$f_0 = 10 \text{ MHz to } 2200 \text{ MHz}$ output level $\leq +10 \text{ dBm}$	>20 dB

Attenuation of nonharmonics	10 MHz to 2200 MHz, at $f > 5 \text{ kHz}$ from carrier	>40 dB
------------------------------------	--	--------

Phase noise	single sideband, $f < 2.2 \text{ GHz}$	
Carrier offset	20 kHz to 250 kHz $\geq 250 \text{ kHz}$	<-100 dBc, 1 Hz <-110 dBc, 1 Hz

Residual FM	30 Hz to 15 kHz ITU-T (formerly CCITT)	<50 Hz, rms, <200 Hz, peak <5 Hz, rms
--------------------	---	--

Residual AM	ITU-T (formerly CCITT)	<0.02%, rms
--------------------	------------------------	-------------

I/Q modulation		
Carrier suppression	data for frequency offset range 0 kHz to $\pm 135 \text{ kHz}$	>40 dB

FM modulation		
Deviation range		10 kHz to 440 kHz
Deviation resolution		1 Hz
Modulation frequency range		1 Hz to 50 kHz
Modulation distortion	modulation frequency 1 kHz, deviation 80 kHz	<2 %
Deviation uncertainty		<5 % + resolution + residual FM

RF analyzer

VSWR		
RF 1	10 MHz to 2000 MHz 2000 MHz to 2200 MHz 2200 MHz to 2700 MHz	<1.2 <1.3 <1.6
RF 2	10 MHz to 2200 MHz 2200 MHz to 2700 MHz	<1.2 <1.6
RF 4 IN	10 MHz to 2200 MHz 2200 MHz to 2700 MHz	<1.5 <1.6

Inherent spurious response	<i>RF Attenuation</i> → <i>Low Distortion</i> , 20 MHz to 2200 MHz, except 1816.115 MHz	<-50 dB
-----------------------------------	---	---------

Inherent harmonics	$f_{in} = 50 \text{ MHz to } 1100 \text{ MHz}$, $f_{selected} = 100 \text{ MHz to } 2200 \text{ MHz}$	
RF 1, RF 2		<-30 dB
RF 4 IN		<-20 dB

Phase noise	single sideband, $f < 2.2$ GHz	
Carrier offset	20 kHz to 250 kHz 250 kHz to 400 kHz ≥ 400 kHz	< -100 dBc, 1 Hz < -110 dBc, 1 Hz < -118 dBc, 1 Hz
Residual FM	30 Hz to 15 kHz ITU-T (formerly CCITT)	< 50 Hz, rms, < 200 Hz, peak < 5 Hz, rms
Residual AM	ITU-T (formerly CCITT)	$< 0.02\%$, rms

Power meter (wideband)

Frequency range		100 kHz to 2700 MHz
Level range		
RF 1	continuous power ³ 100 kHz to 2200 MHz 2200 MHz to 2700 MHz peak envelope power ⁴ (PEP)	+6 dBm to +47 dBm (50 W) +10 dBm to +47 dBm (50 W) +53 dBm (200 W)
RF 2	continuous power 100 kHz to 2200 MHz 2200 MHz to 2700 MHz peak envelope power ⁴ (PEP)	-8 dBm to +33 dBm (2 W) -4 dBm to +33 dBm (2 W) +39 dBm (8 W)
RF 4 IN	continuous power and PEP 100 kHz to 2200 MHz 2200 MHz to 2700 MHz	-33 dBm to 0 dBm -29 dBm to 0 dBm

Level uncertainty		
RF 1	input level +10 dBm to +20 dBm 50 MHz to 2700 MHz input level +20 dBm to +47 dBm 50 MHz to 2700 MHz	< 1.0 dB ⁵ < 0.5 dB ^{5,6}
RF 2	input level -4 dBm to +6 dBm 50 MHz to 2700 MHz input level +6 dBm to +33 dBm 50 MHz to 2700 MHz	< 1.0 dB ⁵ < 0.5 dB ⁵
RF 4 IN	input level -29 dBm to -19 dBm 50 MHz to 2700 MHz input level -19 dBm to 0 dBm 50 MHz to 2700 MHz	< 1.5 dB < 0.8 dB

Level resolution	in manual mode in remote control mode	0.1 dB 0.01 dB
-------------------------	--	-------------------

Power meter (frequency-selective)

Frequency range		10 MHz to 2700 MHz
Frequency resolution		0.1 Hz
Resolution bandwidths		10 Hz to 1 MHz in 1/2/3/5 steps

³ 50 W in temperature range +5 °C to +30 °C, linear degradation down to 25 W at +45 °C.

⁴ Mean value of power vs time must be equal to or less than allowed continuous power.

⁵ Temperature range +5 °C to +20 °C or +35 °C to +45 °C and $f > 2200$ MHz: add 0.2 dB.

⁶ Calibrated for input level $> +33$ dBm only in frequency range 800 MHz to 2000 MHz.

Level range		
RF 1	continuous power ³ 10 MHz to 2200 MHz 2200 MHz to 2700 MHz peak envelope power ⁴ (PEP)	-40 dBm to +47 dBm (50 W) -34 dBm to +47 dBm (50 W) +53 dBm (200 W)
RF 2	continuous power 10 MHz to 2200 MHz 2200 MHz to 2700 MHz peak envelope power ⁴ (PEP)	-54 dBm to +33 dBm (2 W) -48 dBm to +33 dBm (2 W) +39 dBm (8 W)
RF 4 IN	continuous power and PEP 10 MHz to 2200 MHz 2200 MHz to 2700 MHz	-80 dBm to 0 dBm -74 dBm to 0 dBm

Level uncertainty	in temperature range +20 °C to +35 °C	
RF 1, RF 2	50 MHz to 2200 MHz 2200 MHz to 2700 MHz	<0.5 dB <0.7 dB
RF 4 IN	50 MHz to 2200 MHz 2200 MHz to 2700 MHz	<0.7 dB <0.9 dB

Level uncertainty	in temperature range +5 °C to +45 °C	
RF 1, RF 2	50 MHz to 2200 MHz 2200 MHz to 2700 MHz	<1.0 dB <1.0 dB
RF 4 IN	50 MHz to 2200 MHz 2200 MHz to 2700 MHz	<1.0 dB <1.1 dB

Level resolution	in manual mode in remote control mode	0.1 dB 0.01 dB
-------------------------	--	-------------------

RF level measurement repeatability	typical values after 1 h warmup input level \geq -40 dBm input level $<$ -40 dBm	<0.01 dB <0.03 dB
---	--	----------------------

Spectrum analyzer

Frequency range		10 MHz to 2.7 GHz
Span		zero span to full span
Frequency resolution		0.1 Hz
Resolution bandwidths		10 Hz to 1 MHz in 1/2/3/5 steps
Sweep time	depending on resolution bandwidth (RBW)	\geq 100 ms
Display		560 dots, horizontal
Marker		up to 3, absolute/relative
Display line		1
Display scale		10/20/30/50/80/100 dB

Level range		
RF 1	continuous power ³ peak envelope power ⁴ (PEP)	up to +47 dBm (50 W) up to +53 dBm (200 W)
RF 2	continuous power peak envelope power ⁴ (PEP)	up to +33 dBm (2 W) up to +39 dBm (8 W)
RF 4 IN	continuous power and PEP	up to 0 dBm

Level uncertainty	in temperature range +20 °C to +35 °C	
RF 1, RF 2	50 MHz to 2200 MHz 2200 MHz to 2700 MHz	<0.5 dB <0.7 dB
RF 4 IN	50 MHz to 2200 MHz 2200 MHz to 2700 MHz	<0.7 dB <0.9 dB

Level uncertainty	in temperature range +5 °C to +45 °C	
RF 1, RF 2	50 MHz to 2200 MHz 2200 MHz to 2700 MHz	<1.0 dB <1.0 dB
RF 4 IN	50 MHz to 2200 MHz 2200 MHz to 2700 MHz	<1.0 dB <1.1 dB

Reference level for full dynamic range	<i>RF Attenuation</i> → <i>Low Noise</i> , logarithmic level display	
RF 1		+10 dBm to +47 dBm
RF 2		-4 dBm to +33 dBm
RF 4 IN		-22 dBm to 0 dBm

Displayed average noise level	<i>RF Attenuation</i> → <i>Low Noise</i> , <i>RBW</i> → 1 kHz, 10 MHz to 2200 MHz 2200 MHz to 2700 MHz	<-100 dBc <-95 dBc
--------------------------------------	---	-----------------------

Inherent spurious response	<i>RF Attenuation</i> → <i>Low Distortion</i> , 20 MHz to 2200 MHz, except 1816.115 MHz	<-50 dB
-----------------------------------	---	---------

Inherent harmonics	f_{in} = 50 MHz to 1100 MHz, $f_{selected}$ = 100 MHz to 2200 MHz	
RF 1, RF 2		<-30 dB
RF 4 IN		<-20 dB

General specifications

Operating temperature range		+5 °C to +45 °C, meets EN60068-2-1 and -2
Storage temperature range		-25 °C to +60 °C, meets EN60068-2-1 and -2
Humidity	+40 °C, non-condensing	80 % relative humidity, meets EN 60068-2-3

Electromagnetic compatibility		meets EMC Directive 89/336/EEC, applied standard: EN 61326 (immunity for industrial environment; class B emissions)
--------------------------------------	--	--

Electrical safety		IEC 61010-1, EN 61010-1, UL3111-1, CAN/CSA-C22.2 No. 1010.1
--------------------------	--	--

Mechanical resistance	non-operating mode	
Vibration	sinusoidal	meets EN 60068-2-6, EN 61010-1, MIL-T-28800 D class 5, 5 Hz to 150 Hz, max. 2 g at 55 Hz, 55 Hz to 150 Hz, 0.5 g const
Vibration	random	meets EN 60068-2-64 10 Hz to 300 Hz, acceleration 1.2 g rms
Shock		meets EN 60068-2-27, MIL-STD-810D 40 g shock spectrum

Power supply		power factor correction, meets EN61000-3-2
Input		100 V to 240 V ±10 % (AC), max. 500 VA, 50 Hz to 400 Hz -5 % to +10 %
Power consumption	base unit with typical options	approx. 130 W approx. 180 W

Display		21 cm TFT colour display (8.4")
Resolution		640 x 480 pixels (VGA resolution)
Pixel failure rate		$<2 \times 10^{-5}$

Dimensions	W x H x D	465 mm x 193 mm x 517 mm (19"; 4 height units)
-------------------	-----------	---

Weight	base unit with typical options	approx. 14 kg approx. 18 kg
---------------	-----------------------------------	--------------------------------

Inputs and outputs (rear panel)

IF 3 RX CH1		BNC female
Frequency	WCDMA other networks/RF	7.68 MHz 10.7 MHz
Max. output level		0 dBm
Impedance		50 Ω

Remote control interfaces		
IEC/IEEE bus	IEC 60625-2 (IEEE 488.2)	24-pin Amphenol connector
Serial interface COM 1, COM 2	RS-232-C (COM)	9-pin sub-D connector

Printer interface LPT	parallel (Centronics compatible)	25-pin sub-D connector
------------------------------	----------------------------------	------------------------

Keyboard		PS/2 connector
-----------------	--	----------------

External monitor (VGA)		15-pin sub-D connector
-------------------------------	--	------------------------

GSM specifications – mobile station test

RF generator

Modulation		GMSK, B x T = 0.3 8PSK
-------------------	--	---------------------------

Frequency range		
	GSM400 band	460 MHz to 468 MHz 488 MHz to 496 MHz
	GSM850 band	869 MHz to 894 MHz
	GSM900 band	921 MHz to 960 MHz
	GSM1800 band	1805 MHz to 1880 MHz
	GSM1900 band	1930 MHz to 1990 MHz

Attenuation of inband spurious emissions		>50 dB
---	--	--------

Inherent phase error	GMSK	<1°, rms <4°, peak
-----------------------------	------	-----------------------

Inherent EVM	8PSK	<2 %, rms
---------------------	------	-----------

Frequency settling time	to residual phase of 4°	<500 µs
--------------------------------	-------------------------	---------

Output level range	GMSK	
RF 1		-130 dBm to -27 dBm
RF 2		-130 dBm to -10 dBm
RF 3 OUT		-90 dBm to +13 dBm

Output level range	8PSK	
RF 1		-130 dBm to -31 dBm
RF 2		-130 dBm to -14 dBm
RF 3 OUT		-90 dBm to +9 dBm

Output level resolution		0.1 dB
--------------------------------	--	--------

Output level uncertainty	in temperature range +20 °C to 35 °C	
RF 1, RF 2	output level >-117 dBm	<0.5 dB
RF 3 OUT	-90 dBm to +10 dBm (GMSK) -90 dBm to +6 dBm (8PSK)	<0.7 dB <0.7 dB

Output level uncertainty	in temperature range +5 °C to 45 °C	
RF 1, RF 2	output level >-117 dBm	<0.7 dB
RF 3 OUT	-90 dBm to +10 dBm (GMSK) -90 dBm to +6 dBm (8PSK)	<0.9 dB <0.9 dB

Option Additional RF Generator R&S CMU-B95

Modulation		GMSK, B x T = 0.3 8PSK
Frequency range		
	GSM400 band	460 MHz to 468 MHz 488 MHz to 496 MHz
	GSM850 band	869 MHz to 894 MHz
	GSM900 band	921 MHz to 960 MHz
	GSM1800 band	1805 MHz to 1880 MHz
	GSM1900 band	1930 MHz to 1990 MHz
Frequency resolution		200 kHz
Frequency uncertainty		same as time base, see base unit specifications
Inherent phase error	GMSK	< 5°, rms
Output level range	GMSK	
RF 1	without R&S CMU-B99 with R&S CMU-B99	-122 dBm to -72 dBm -110 dBm to -60 dBm
RF 2		-110 dBm to -60 dBm
Output level range	8PSK	
RF 1	without R&S CMU-B99 with R&S CMU-B99	-122 dBm to -76 dBm -110 dBm to -64 dBm
RF 2		-110 dBm to -64 dBm
Output level resolution		1 dB
Reduced input level range	if R&S CMU-B95 is installed	
RF 1	continuous input power	max. 2 W

RF analyzer

Frequency range		
	GSM400 band	450 MHz to 458 MHz 478 MHz to 486 MHz
	GSM850 band	824 MHz to 849 MHz
	GSM900 band	876 MHz to 915 MHz
	GSM1800 band	1710 MHz to 1785 MHz
	GSM1900 band	1850 MHz to 1910 MHz

Power meter (frequency-selective)

Level range		
RF 1	continuous power ³ peak envelope power ⁴ (PEP)	-40 dBm to +47 dBm (50 W) +53 dBm (200 W)
RF 2	continuous power peak envelope power ⁴ (PEP)	-54 dBm to +33 dBm (2 W) +39 dBm (8 W)
RF 4 IN	continuous power and PEP	-80 dBm to 0 dBm
Level uncertainty	in temperature range +20 °C to +35 °C in temperature range +5 °C to +45 °C	<0.5 dB <0.7 dB

Level resolution	in manual mode	0.1 dB
	in remote control mode	0.01 dB

Measurement bandwidth	selectable	500 kHz or 600 kHz
------------------------------	------------	--------------------

Modulation analysis

Level range	peak envelope power (PEP)	
RF 1	see footnote ⁴	-6 dBm to +53 dBm
RF 2	see footnote ⁴	-20 dBm to +39 dBm
RF 4 IN		-60 dBm to 0 dBm

Inherent phase error	GMSK	<0.6°, rms <2°, peak
-----------------------------	------	-------------------------

Inherent EVM	8PSK	≤1.0 %, rms
---------------------	------	-------------

Frequency measurement uncertainty		≤10 Hz + drift of time base, see base unit specifications
--	--	--

Measurement bandwidth	selectable	500 kHz or 600 kHz
------------------------------	------------	--------------------

Burst power measurement

Reference level for full dynamic range	GMSK, <i>RF Attenuation → Low Noise</i>	
RF 1	see footnote ⁴	+10 dBm to +53 dBm
RF 2	see footnote ⁴	-4 dBm to +39 dBm
RF 4 IN		-22 dBm to 0 dBm

Reference level for full dynamic range	8PSK, <i>RF Attenuation → Low Noise</i>	
RF 1	see footnote ⁴	+6 dBm to +49 dBm
RF 2	see footnote ⁴	-8 dBm to +35 dBm
RF 4 IN		-26 dBm to -4 dBm

Dynamic range	<i>Filter → 500 kHz, rms, RF Attenuation → Low Noise</i>	
	GMSK	>72 dB
	8PSK	>69 dB

Relative measurement uncertainty	result > -40 dB	<0.1 dB
	-60 dB ≤ result ≤ -40 dB	<0.5 dB

Resolution	in active part of burst	0.1 dB
-------------------	-------------------------	--------

Measurement bandwidth	selectable	500 kHz or 600 kHz
------------------------------	------------	--------------------

Spectrum due to modulation

Reference level for full dynamic range	GMSK, <i>RF Attenuation</i> → <i>Low Noise</i>	
RF 1		+10 dBm to +47 dBm
RF 2		-4 dBm to +33 dBm
RF 4 IN		-22 dBm to 0 dBm
Test method		relative measurement, averaging
Filter bandwidth		30 kHz resolution filter, 5 pole
Measurement	at an offset of	100, 200, 250, 400, 600, 800, 1000, 1200, 1400, 1600, 1800 kHz
Dynamic range	with offset ≥ 1200 kHz	>74 dB

Spectrum due to switching

Reference level for full dynamic range	GMSK, <i>RF Attenuation</i> → <i>Low Noise</i>	
RF 1		+10 dBm to +47 dBm
RF 2		-4 dBm to +33 dBm
RF 4 IN		-22 dBm to 0 dBm
Test method		absolute measurement, max. hold over several measurements
Filter bandwidth		30 kHz resolution filter, 5 pole
Measurement	at an offset of	400, 600, 800, 1200, 1800 kHz
Dynamic range	with offset ≥1200 kHz	>72 dB

Option Speech Codec R&S CMU-B52

Speech decoder output	SPEECH HANDSET OUT	9-pin sub-D connector
Output impedance		<10 Ω
Maximum output current		20 mA, peak
Full-range output level		1 V, peak
Speech coder input	SPEECH HANDSET IN	9-pin sub-D connector
Input impedance		100 kΩ
Full-range input level	low sensitivity	1.4 V, peak
	high sensitivity	0.1 V, peak

TDMA specifications – mobile station test

RF generator

Frequency range	signalling mode	
	US Cellular	869 MHz to 894 MHz
	PCS (US)	1930 MHz to 1990 MHz
Frequency range	non-signalling mode	10 MHz to 2200 MHz
Frequency resolution	non-signalling mode	1 Hz
Frequency uncertainty		same as time base, see base unit specifications
Output level range		
	RF 1	-130 dBm to -32 dBm
	RF 2	-130 dBm to -15 dBm
	RF 3 OUT	-90 dBm to +8 dBm
Output level resolution		0.1 dB
Output level uncertainty		see base unit specifications
Modulation	$\pi/4$ DQPSK or unmodulated (non-signalling mode)	
	Uncertainty	EVM
	Carrier suppression	
		<2.5 %, rms
		>40 dB

RF analyzer

Frequency range	signalling mode	
	US Cellular	824 MHz to 849 MHz
	PCS (US)	1850 MHz to 1910 MHz
Frequency range	non-signalling mode	10 MHz to 2200 MHz
Frequency resolution	non-signalling mode	1 Hz
Frequency uncertainty		same as time base, see base unit specifications

Modulation analysis

Frequency range	signalling mode	
	US Cellular	824 MHz to 849 MHz
	PCS (US)	1850 MHz to 1910 MHz
EVM		
	residual	<2.0 %, rms
	residual	<4 %, peak

I/Q offset	residual	<-50 dB (0.3%)
I/Q imbalance	residual	<-50 dB (0.3%)
Frequency measurement range		-2 kHz to +2 kHz
Frequency measurement uncertainty		≤5 Hz + drift of time base, see base unit specifications

Power meter (frequency-selective)

Level range		see base unit specifications
Level uncertainty		see base unit specifications

Power versus time measurement

Reference level for full dynamic range		
RF 1		+4 dBm to +47 dBm
RF 2		-10 dBm to +33 dBm
RF 4 IN		-28 dBm to -6 dBm
Dynamic range	<i>Filter → 100 kHz, rms, RF Attenuation → Low Noise</i>	>74 dB
Relative measurement uncertainty		
	result > -40 dB	<0.1 dB
	-60 dB ≤ result ≤ -40 dB	<0.5 dB
Residual leakage power level		<-65 dBm

Adjacent channel power measurement

Dynamic range		
	first adjacent channel	>45 dB
	second and third adjacent channel	>55 dB

AMPS specifications – mobile station test

RF generator

Frequency range	signalling mode	
	US Cellular	869 MHz to 894 MHz
Frequency range	non-signalling mode	10 MHz to 2200 MHz
Frequency resolution	non-signalling mode	1 Hz
Frequency uncertainty		same as time base, see base unit specifications
Output level range		
RF 1		-130 dBm to -27 dBm
RF 2		-130 dBm to -10 dBm
RF 3 OUT		-99 dBm to +13 dBm
Output level resolution		0.1 dB
Output level uncertainty		see base unit specifications and add 0.1 dB
FM modulation		
Deviation range		100 Hz to 20 kHz
Deviation resolution		1 Hz
Modulation frequency range		100 Hz to 15.999 kHz
Modulation distortion	SINAD, modulation frequency 1 kHz, deviation 8 kHz, BW 30 Hz to 15 kHz	≥40 dB
Residual FM	BW 300 Hz to 3 kHz	<10 Hz, rms
Deviation uncertainty	modulation frequency 1 kHz, deviation 8 kHz, BW 30 Hz to 15 kHz	<2 % of setting + residual FM
Deviation frequency response	modulation frequency 300 Hz to 15.999 kHz	≤1 dB

RF analyzer

Frequency range	signalling mode	
	US Cellular	824 MHz to 849 MHz
Frequency range	non-signalling mode	10 MHz to 2200 MHz
Frequency resolution	non-signalling mode	1 Hz
Frequency uncertainty		same as time base, see base unit specifications

Power meter (frequency-selective)

Max. level range		
RF 1		0 dBm to +53 dBm
RF 2		-14 dBm to +39 dBm
RF 4 IN		-37 dBm to +0 dBm

Level uncertainty		see base unit specifications
--------------------------	--	------------------------------

Level resolution		0.1 dB
-------------------------	--	--------

FM measurement

Dynamic range		30 dB below max. level
----------------------	--	------------------------

RF bandwidth	2 x deviation + 4 x modulation frequency	136 kHz
---------------------	--	---------

Deviation range		0 kHz to 47 kHz
------------------------	--	-----------------

Resolution		1 Hz
-------------------	--	------

Modulation frequency range		100 Hz to 18 kHz
-----------------------------------	--	------------------

Residual FM		
	BW 300 Hz to 3 kHz	<5 Hz, rms
	BW 6 Hz to 20 kHz	<18 Hz, rms

Deviation uncertainty	BW 6 Hz to 20 kHz	<1 % of reading + residual FM
------------------------------	-------------------	-------------------------------

Carrier frequency error		
Measurement range		-47 kHz to +47 kHz
Measurement uncertainty		≤2 kHz + drift of time base, see base unit specifications

AF generator

See specifications of Option Audio Generator/Analyzer R&S CMU-B41		
---	--	--

AF analyzer

See specifications of Option Audio Generator/Analyzer R&S CMU-B41		
---	--	--

cdma2000 specifications – mobile station test

Standards	cdma2000 standards cdma2000 test standards	TIA/EIA IS-2000 Rev. 0 TIA/EIA IS-98-E
------------------	---	---

RF generator

Frequency range		
	NMT-450 (band class 5)	421.675 MHz to 494.480 MHz
	US / Korean Cellular (band class 0)	869.025 MHz to 893.985 MHz
	TACS Band (band class 2)	917.0125 MHz to 959.9875 MHz
	JTACS Band (band class 3)	832.0125 MHz to 869.9875 MHz
	North American 700 MHz Cellular Band (band class 7)	746.000 MHz to 764.000 MHz
	900 MHz Band (band class 9)	925.000 MHz to 958.750 MHz
	Secondary 800 MHz Band (band class 10)	851.000 MHz to 939.975 MHz
	North American PCS (band class 1)	1930.000 MHz to 1990.000 MHz
	Korean PCS (band class 4)	1840.000 MHz to 1870.000 MHz
	1800 MHz Band (band class 8)	1805.000 MHz to 1879.950 MHz
	IMT-2000 (band class 6)	2110.000 MHz to 2169.950 MHz

Frequency resolution	channel spacing according to standard	
-----------------------------	---------------------------------------	--

Frequency uncertainty		same as time base, see base unit specifications
------------------------------	--	--

Output level range	modulated signal	
RF 1		-120 dBm to -33 dBm
RF 2		-120 dBm to -16 dBm
RF 3 OUT		-99 dBm to +5 dBm

Output level resolution	modulated signal	0.1 dB
--------------------------------	------------------	--------

Output level uncertainty	in temperature range +20 °C to +35 °C	
RF 1, RF 2	output level \geq -108 dBm	<0.5 dB
RF 3 OUT	-80 dBm to +4 dBm	<0.7 dB

Output level uncertainty	in temperature range +5 °C to +45 °C	
RF 1, RF 2	output level \geq -108 dBm	<0.7 dB
RF 3 OUT	-80 dBm to +4 dBm	<0.9 dB

Modulation		
Dual BPSK, multiple QPSK		1.2288 Mcps
AWGN		see AWGN generator
Carrier suppression		>35 dB
Waveform quality factor (ρ)		>0.985
Code channel level uncertainty	relative to the total CDMA power F-PICH, F-PCH, F-FCH, F-SCH1, F-SCH2 all other channels	approx. 0.1 dB approx. 0.25 dB
Code channel resolution		0.1 dB

AWGN generator		
Bandwidth		>1.8 MHz
Output level resolution		0.1 dB
Output level uncertainty	bandwidth 1.23 MHz	approx. 0.2 dB
Output level range	relative to total CDMA output power	-20 dB to +4 dB

Supported service options		
Loopback service options		SO 2, 9, 55
Speech service options		SO 1, 3, 17, 0x8000
Test data service option		SO 32
Packet data service option		SO 33
Messaging teleservice option		SO 6, 14

RF analyzer

Frequency range		
	NMT-450 (band class 5)	411.675 MHz to 483.480 MHz
	US/Korean Cellular (band class 0)	824.025 MHz to 848.985 MHz
	TACS Band (band class 2)	872.0125 MHz to 914.9875 MHz
	JTACS Band (band class 3)	887.0125 MHz to 924.9875 MHz
	North American 700 MHz Cellular Band (band class 7)	776.000 MHz to 794.000 MHz
	900 MHz Band (band class 9)	880.000 MHz to 913.750 MHz
	Secondary 800 MHz Band (band class 10)	806.000 MHz to 900.975 MHz
	North American PCS (band class 1)	1850.000 MHz to 1910.000 MHz
	Korean PCS (band class 4)	1750.000 MHz to 1780.000 MHz
	1800 MHz Band (band class 8)	1710.000 MHz to 1784.950 MHz
	IMT-2000 (band class 6)	1920.000 MHz to 1979.950 MHz

Measurement filter	according to standard	bandwidth 1.23 MHz
---------------------------	-----------------------	--------------------

Frequency resolution	channel spacing according to standard	
-----------------------------	---------------------------------------	--

Frequency uncertainty		same as time base, see base unit specifications
------------------------------	--	--

Power meter (frequency-selective)

Level range	HPSK, O-QPSK signal	
RF 1		-40 dBm to +44 dBm
RF 2		-54 dBm to +30 dBm
RF 4 IN		-80 dBm to -9 dBm

Level uncertainty		
RF 1, RF 2, RF 4 IN	in temperature range +20 °C to +35 °C	<0.5 dB
	in temperature range +5 °C to +45 °C	<0.7 dB

Level resolution		0.1 dB
-------------------------	--	--------

Modulation analyzer

Level range	HPSK, O-QPSK signal	
RF 1		-40 dBm to +44 dBm
RF 2		-54 dBm to +30 dBm
RF 4 IN		-80 dBm to -9 dBm

RC1, RC2 (O-QPSK)	waveform quality, error vector magnitude, magnitude error, phase error	
ρ uncertainty (for ρ 0.9 to 1)		<0.003
Frequency measurement range		-3 kHz to +3 kHz
Frequency measurement uncertainty		<30 Hz + drift of time base, see base unit specifications

RC3, RC4 (HPSK)	waveform quality, error vector magnitude, magnitude error, phase error, channel power, code domain power, peak code domain error power,	
ρ uncertainty (for ρ 0.9 to 1)		<0.003
Frequency measurement range		-3 kHz to +3 kHz
Frequency measurement uncertainty		<10 Hz + drift of time base, see base unit specifications
Relative measurement uncertainty	result >-33 dB	<0.1 dB

Option Speech Codec R&S CMU-B85

Speech decoder output	SPEECH HANDSET OUT	9-pin sub-D connector
Output impedance		<10 Ω
Maximum output current		20 mA, peak
Full-range output level		1 V, peak

Speech coder input	SPEECH HANDSET IN	9-pin sub-D connector
Input impedance		100 k Ω
Full-range input level	low sensitivity high sensitivity	1.4 V, peak 0.1 V, peak

1xEV-DO specifications – access terminal test

Standards	1xEV-DO standards 1xEV-DO test standards	TIA/EIA IS-856-2 TIA/EIA IS-866
------------------	---	------------------------------------

RF generator

Frequency range		
	US / Korean Cellular (band class 0)	869.025 MHz to 893.985 MHz
	North American PCS (band class 1)	1930.000 MHz to 1990.000 MHz
	TACS Band (band class 2)	917.0125 MHz to 959.9875 MHz
	JTACS Band (band class 3)	832.0125 MHz to 869.9875 MHz
	Korean PCS (band class 4)	1840.000 MHz to 1870.000 MHz
	NMT-450 (band class 5)	421.675 MHz to 494.480 MHz
	IMT-2000 (band class 6)	2110.000 MHz to 2169.950 MHz
	North American 700 MHz Cellular Band (band class 7)	746.000 MHz to 764.000 MHz
	1800 MHz Band (band class 8)	1805.000 MHz to 1879.950 MHz
	900 MHz Band (band class 9)	925.000 MHz to 958.750 MHz
	Secondary 800 MHz Band (band class 10)	851.000 MHz to 939.975 MHz

Frequency resolution	channel spacing according to standard	
-----------------------------	---------------------------------------	--

Frequency uncertainty		same as time base, see base unit specifications
------------------------------	--	--

Output level range	modulated signal	
RF 1		-120 dBm to -33 dBm
RF 2		-120 dBm to -16 dBm
RF 3 OUT		-99 dBm to +5 dBm

Output level resolution	modulated signal	0.1 dB
--------------------------------	------------------	--------

Output level uncertainty	in temperature range +20 °C to +35 °C	
RF 1, RF 2	output level \geq -108 dBm	<0.5 dB
RF 3 OUT	-80 dBm to +4 dBm	<0.7 dB

Output level uncertainty	in temperature range +5 °C to +45 °C	
RF 1, RF 2	output level \geq -108 dBm	<0.7 dB
RF 3 OUT	-80 dBm to +4 dBm	<0.9 dB

Modulation		
Dual BPSK		1.2288 Mcps
AWGN		see AWGN generator
Carrier suppression		>35 dB
Waveform quality factor (ρ)		>0.985
Code channel level uncertainty	relative to total CDMA power	approx. 0.1 dB
Code channel resolution		0.1 dB
Code channel level range		-25.0 dB to -7.0 dB

AWGN generator		
Bandwidth		>1.8 MHz
Output level resolution		0.1 dB
Output level uncertainty	bandwidth 1.23 MHz	approx. 0.2 dB
Output level range	relative to total CDMA output power	-20 dB to +4 dB

RF analyzer

Frequency range		
	US / Korean Cellular (band class 0)	824.025 MHz to 848.985 MHz
	North American PCS (band class 1)	1850.000 MHz to 1910.000 MHz
	TACS Band (band class 2)	872.0125 MHz to 914.9875 MHz
	JTACS Band (band class 3)	887.0125 MHz to 924.9875 MHz
	Korean PCS (band class 4)	1750.000 MHz to 1780.000 MHz
	NMT-450 (band class 5)	411.675 MHz to 483.480 MHz
	IMT-2000 (band class 6)	1920.000 MHz to 1979.950 MHz
	North American 700 MHz Cellular Band (band class 7)	776.000 MHz to 794.000 MHz
	1800 MHz Band (band class 8)	1710.000 MHz to 1784.950 MHz
	900 MHz Band (band class 9)	880.000 MHz to 913.750 MHz
	Secondary 800 MHz Band (band class 10)	806.000 MHz to 900.975 MHz

Measurement filter	according to standard	bandwidth 1.23 MHz
---------------------------	-----------------------	--------------------

Frequency resolution	channel spacing according to standard	
-----------------------------	---------------------------------------	--

Frequency uncertainty		same as time base, see base unit specifications
------------------------------	--	--

Power meter (frequency-selective)

Level range	modulated signal	
RF 1		-40 dBm to +44 dBm
RF 2		-54 dBm to +30 dBm
RF 4 IN		-80 dBm to -9 dBm

Level uncertainty		
RF 1, RF 2, RF 4 IN	in temperature range +20 °C to +35 °C	<0.5 dB
	in temperature range +5 °C to +45 °C	<0.7 dB

Level resolution		0.1 dB
-------------------------	--	--------

Modulation analyzer

Level range	modulated signal	
RF 1		-40 dBm to +44 dBm
RF 2		-54 dBm to +30 dBm
RF 4 IN		-80 dBm to -9 dBm

Waveform quality (ρ) uncertainty	(for ρ 0.9 to 1)	<0.003
Frequency measurement range		-3 kHz to +3 kHz
Frequency measurement uncertainty		<10 Hz + drift of time base, see base unit specifications
Relative measurement uncertainty	result >-33 dB	<0.1 dB

WCDMA specifications – mobile station (UE) test

Standard		3GPP FDD
Symbol rate		3.84 MHz

Synchronization output 2		BNC connector REF OUT 2
Frequency		30.72 MHz / n, n = 1 to 32

RF generator

Channels	non-signalling mode	
	P-CPICH, P-SCH, S-SCH, P-CCPCH, PICH, DPCH	
	OCNS	16-channel orthogonal channel noise
	reference measurement channels (RMC) according to 3GPP TS 34.121	12.2 kbit/s, 64 kbit/s, 144 kbit/s, 384 kbit/s

Channels	signalling mode, codes selectable until conflict in code space occurs	
	P-CPICH, P-SCH, S-SCH, P-CCPCH, S-CCPCH, AICH, PICH	
	OCNS	16-channel orthogonal channel noise
	DPCH signalling radio bearer (SRB)	1.7 kbit/s, 2.5 kbit/s, 3.4 kbit/s, 13.6 kbit/s
	DPCH reference measurement channels (RMC) according to 3GPP TS 34.121 DL and UL DL/UL BTFD	12.2 kbit/s, 64 kbit/s, 144 kbit/s, 384 kbit/s 144 kbit/s / 64 kbit/s, 384 kbit/s / 64 kbit/s, 384 kbit/s / 144 kbit/s 1.95 kbit/s, 4.75 kbit/s, 5.15 kbit/s, 5.9 kbit/s, 6.7 kbit/s, 7.4 kbit/s, 7.95 kbit/s 10.2 kbit/s, 12.2 kbit/s
	DPCH voice (echo or speech codec)	4.75 kbit/s, 5.15 kbit/s, 5.9 kbit/s, 6.7 kbit/s, 7.4 kbit/s, 7.95 kbit/s 10.2 kbit/s, 12.2 kbit/s

Frequency range	non-signalling mode	869 MHz to 894 MHz 921 MHz to 960 MHz 1805 MHz to 1880 MHz 1930 MHz to 1990 MHz 2110 MHz to 2170 MHz
------------------------	---------------------	--

Frequency range	signalling mode band 1 band 2 band 3	2110 MHz to 2170 MHz 1930 MHz to 1990 MHz 1805 MHz to 1880 MHz
------------------------	---	--

Frequency offset		-100 kHz to +100 kHz
-------------------------	--	----------------------

Frequency resolution		0.1 Hz
-----------------------------	--	--------

Frequency setting		by channel number or frequency
--------------------------	--	--------------------------------

Output level range		
RF 1		-120 dBm to -37 dBm
RF 2		-120 dBm to -20 dBm
RF 3 OUT		-100 dBm to 0 dBm

Output level resolution	manual mode remote mode	0.1 dB 0.01 dB
Output level uncertainty	in temperature range +20 °C to +35 °C	
RF 1, RF 2	output level ≥ -120 dBm	<0.6 dB
RF 3 OUT	output level ≥ -80 dBm	<0.8 dB
Output level uncertainty	in temperature range +5 °C to +45 °C	
RF 1, RF 2	output level ≥ -120 dBm	<0.9 dB
RF 3 OUT	output level ≥ -80 dBm	<1.0 dB
Output level setting	setting reference	relative to CPICH or total output power
Channel levels	non-signalling mode	
	P-CPICH, P-SCH, S-SCH, P-CCPCH, PICH, DPCH, OCNS	-30 dB to +15 dB relative to CPICH
Channel levels	signalling mode	
	P-CPICH, P-SCH, S-SCH, P-CCPCH, S-CCPCH, PICH, AICH, DPCH, OCNS	-30 dB to +15 dB relative to CPICH
Signal quality		
Error vector magnitude (EVM)	global EVM for DL RMC according to 3GPP TS 34.121 C3.1 to C3.4 with DPCH/CPICH = 0 dB	<8 %, rms

RF analyzer (TX measurements)

Frequency range	non-signalling mode	824 MHz to 849 MHz 876 MHz to 915 MHz 1710 MHz to 1785 MHz 1850 MHz to 1910 MHz 1920 MHz to 1980 MHz
Frequency range	signalling mode band 1 band 2 band 3	1920 MHz to 1980 MHz 1850 MHz to 1910 MHz 1710 MHz to 1785 MHz
Frequency offset		-100 kHz to +100 kHz
Frequency resolution		1 Hz
Frequency setting		by channel number or frequency
Level setting		by autoranging or manual mode
Max. level setting range		
RF 1	peak envelope power ⁴ (PEP)	-38 dBm to +53 dBm
RF 2	peak envelope power ⁴ (PEP)	-52 dBm to +39 dBm
RF 4 IN	peak envelope power (PEP)	-77 dBm to +0 dBm
Statistics		
Statistic count		1 to 1000
Values		current, average, min/max

Trigger		
Trigger sources		free run, internal, external, IF power
Trigger slot delay		0 to 14 slots
Trigger delay offset		-10239 to + 10239 x 1/4 chip
Trigger output	24-pin sub-D connector AUX 3	downlink frame, downlink slot, TPC trigger

Modulation analysis

Measurement filter	receiver filter according to standard	3.84 MHz, RRC, $\alpha = 0.22$
---------------------------	---------------------------------------	--------------------------------

Analysis modes		QPSK, WCDMA uplink
-----------------------	--	--------------------

Input level range		
RF 1	continuous power ³ peak envelope power ⁴ (PEP)	-21 dBm to +47 dBm -16 dBm to +53 dBm
RF 2	continuous power peak envelope power ⁴ (PEP)	-35 dBm to +33 dBm -30 dBm to +39 dBm
RF 4 IN	continuous power and PEP	-50 dBm to 0 dBm

Error vector magnitude (EVM)		
Measurement range		up to 25%
Applications	non-signalling mode	overview EVM versus time, graphical ME versus time, graphical PE versus time, graphical I/Q analyser
Measured parameters		error vector magnitude magnitude error phase error I/Q origin offset I/Q imbalance peak code domain error waveform quality
Inherent EVM	<i>RF Attenuation</i> → <i>Low Noise</i> <i>RF Attenuation</i> → <i>Low Noise</i> , with R&S CMU-Z6 calibration	<2.5 %, rms <1.5 %, rms
Resolution		0.1%
Measurement length	QPSK mode WCDMA mode	1 timeslot (2560 chips) 1/4 timeslot (640 chips) 1 timeslot
Marker	in graphical menus	reference , Abs1, Abs2, D-line

Frequency error		
Measurement range		±3 kHz
Uncertainty		<10 Hz + drift of time base, see base unit specifications
Resolution		1 Hz

I/Q offset		
Inherent I/Q offset		<-55 dB
Resolution		0.01 dB

I/Q imbalance		
Inherent I/Q imbalance		<-30 dB
Resolution		0.01 dB

Peak code domain error (PCDE)		
Inherent PCDE	for SF = 4	<-40 dB
Resolution		0.01 dB

I/Q analyzer	non-signalling mode	
Display	QPSK mode and WCDMA mode waveform type zoom rotation measurement length	graphical display constellation diagram, vector diagram, eye diagram I, Q, I/Q 1, 2, 5, 10, 20 0°, 45° 1 timeslot (2560 chips), 1/4 timeslot (640 chips)

Spectrum measurements

Reference level for full dynamic range		
RF 1	rms peak envelope power ⁴ (PEP)	+14 dBm to +47 dBm up to +53 dBm
RF 2	rms peak envelope power ⁴ (PEP)	+0 dBm to +33 dBm up to +39 dBm
RF 4 IN	rms peak envelope power (PEP)	-18 dBm to 0 dBm up to 0 dBm

Adjacent channel leakage ratio (ACLR filter application)		
Measurement filter	receiver filter according to standard	3.84 MHz, RRC, $\alpha = 0.22$
Display		bar graphs of rms and peak values, numerical values rms and peak of current, average and max. values
Frequency offsets	first adjacent channel second adjacent channel	± 5 MHz ± 10 MHz
Uncertainty	for -33 dBc first adjacent channel level for -43 dBc second adjacent channel level	<0.5 dB <0.5 dB
Dynamic range (High dynamic mode → On)	first adjacent channel second adjacent channel	>54 dB >64 dB
Resolution		0.1 dB
Measurement length		1 timeslot (2560 chips) 1/2 timeslot (1280 chips) 1/4 timeslot (640 chips) 1/8 timeslot (320 chips)

Adjacent channel leakage ratio (ACLR FFT/OBW application)		
Measurement filter	receiver filter according to standard	3.84 MHz, RRC, $\alpha = 0.22$
Display		continuous spectrum with 25 MHz bandwidth, numerical values rms and peak of current, average and max. values
Frequency offsets	first adjacent channel second adjacent channel	± 5 MHz ± 10 MHz
Resolution bandwidth		20 kHz, 3.84 MHz
Dynamic range (High dynamic mode → On)	first adjacent channel second adjacent channel	>54 dB >64 dB
Occupied bandwidth	measurement range	1 MHz to 6 MHz
	measurement uncertainty	<50 kHz
	measurement resolution	20 kHz
Measurement length		1 timeslot (2560 chips) 1/2 timeslot (1280 chips) 1/4 timeslot (640 chips) 1/8 timeslot (320 chips)

Spectrum emission mask (SEM application)		
Measurement filter	receiver filter according to standard	3.84 MHz, RRC, $\alpha = 0.22$
Display		graphical and numerical values of current, average and max values
Resolution bandwidth	frequency offset 2.5 MHz to 3.5 MHz 3.5 MHz to 7.5 MHz 7.5 MHz to 8.5 MHz 8.5 MHz to 12.5 MHz	30 kHz 1 MHz 1 MHz 1 MHz
Measurement interval		1 timeslot (2560 chips) 1/2 timeslot (1280 chips) 1/4 timeslot (640 chips) 1/8 timeslot (320 chips)

Power meter (frequency-selective)⁷

Measurement applications	maximum power, minimum power off power power versus slot inner loop power	bandwidth approx. 7 MHz 3.84 MHz, RRC, $\alpha = 0.22$ bandwidth approx. 7 MHz 3.84 MHz, RRC, $\alpha = 0.22$
---------------------------------	--	--

Power versus slot	measurement width step width step count step delay	0.25, 0.5, 1 slot 1 slot to 30 slots 1 to 100 0 to 100
--------------------------	---	---

Level range		
RF 1	continuous power ³ peak envelope power ⁴ (PEP)	-52 dBm to +47 dBm -42 dBm to +53 dBm
RF 2	continuous power peak envelope power ⁴ (PEP)	-66 dBm to +33 dBm -56 dBm to +39 dBm
RF 4 IN	continuous power ⁸ peak envelope power (PEP)	-89 dBm to 0 dBm -79 dBm to 0 dBm

Level uncertainty	in temperature range +20 °C to +35 °C	
RF 1	-10 dBm to +47 dBm, rms -44 dBm to -10 dBm, rms	<0.5 dB <0.7 dB
RF 2	-24 dBm to +33 dBm, rms -60 dBm to -24 dBm, rms	<0.5 dB <0.7 dB
RF 4 IN	-24 dBm to 0 dBm, rms -85 dBm to -24 dBm, rms	<0.5 dB <0.7 dB

Level uncertainty	in temperature range +5 °C to +45 °C	
RF 1	-10 dBm to +47 dBm, rms -44 dBm to -10 dBm, rms	<0.7 dB <0.9 dB
RF 2	-24 dBm to +33 dBm, rms -60 dBm to -24 dBm, rms	<0.7 dB <0.9 dB
RF 4 IN	-24 dBm to 0 dBm, rms -85 dBm to -24 dBm, rms	<0.7 dB <0.9 dB

Level resolution		0.01 dB
-------------------------	--	---------

⁷ The specified data is valid for *RF Attenuation* set to *Low Noise*.

⁸ Upper limit depends on crest factor.

Code domain power ⁷

Measurement filter	receiver filter according to standard	3.84 MHz, RRC, $\alpha = 0.22$
Display modes		CDP/Code Auto CDP/Code Manual CDP/Code Rho Auto CDP/Code Rho Manual
Spreading Factor (SF)	auto mode manual setting	4, 8, 16, 32, 64, 128, 256

Level range		
RF 1		-8 dBm to +47 dBm
RF 2		-22 dBm to +33 dBm
RF 4 IN		-45 dBm to 0 dBm

Level uncertainty		<0.5 dB
--------------------------	--	---------

Level resolution		0.01 dB
-------------------------	--	---------

Receiver quality (bit error rate measurements)

Measurement types		BER, BLER, DBLER, FDR
Measurement method		loopback mode 2, loopback mode 1 with RLC transparent
Number of transport blocks		1 to 50000
DL/UL transport block size		symmetric, asymmetric
DL/UL timing		876 chips to 1172 chips

Option Speech Codec R&S CMU-B52

Speech decoder output	SPEECH HANDSET OUT	9-pin sub-D connector
Output impedance		<10 Ω
Maximum output current		20 mA, peak
Full-range output level		1 V, peak

Speech coder input	SPEECH HANDSET IN	9-pin sub-D connector
Input impedance		100 k Ω
Full-range input level	low sensitivity high sensitivity	1.4 V, peak 0.1 V, peak

Bluetooth specifications

Standards		Bluetooth Core Specifications Version 1.1
------------------	--	---

RF generator

RF channel definition		2402 MHz + k x 1 MHz, k = 0 to 93
------------------------------	--	-----------------------------------

Frequency range		2402 MHz to 2495 MHz
------------------------	--	----------------------

Frequency resolution	channel spacing according to standard	1 MHz
-----------------------------	---------------------------------------	-------

Frequency offset range		±500 kHz
-------------------------------	--	----------

Frequency offset resolution		1 kHz
------------------------------------	--	-------

Frequency uncertainty		±1 Hz + drift of time base, see base unit specifications
------------------------------	--	---

Hopping scheme	modes according to standard	Europe (except France), USA France RX/TX single frequency Reduced hopping
-----------------------	-----------------------------	--

Output level range	modulated signal	
RF 1		-106 dBm to -33 dBm
RF 2		-106 dBm to -12 dBm
RF 3 OUT		-90 dBm to +5 dBm

Output level uncertainty	in temperature range +20 °C to 35 °C	
RF 1, RF 2		<0.9 dB
RF 3 OUT		<1.1 dB

Output level uncertainty	in temperature range +5 °C to +45 °C	
RF 1, RF 2		<1.6 dB
RF 3 OUT		<1.6 dB

Output level resolution		0.1 dB
--------------------------------	--	--------

Modulation		
GFSK	AC coupling cut-off frequency 100 Hz	1 Mbps, B x T = 0.5
Modulation index	11110000 pattern, frequency deviation 160 kHz	0.32
Modulation index range	frequency deviation 100 kHz to 220 kHz	0.20 to 0.44
Modulation index resolution		0.01
Modulation index uncertainty	11110000 pattern, frequency deviation 160 kHz	±5 %

RF analyzer

RF channel definition		2402 MHz + k x 1 MHz, k = 0 to 93
Frequency range		2402 MHz to 2495 MHz
Frequency resolution	channel spacing according to standard	1 MHz
Frequency uncertainty		±1 Hz + drift of time base, see base unit specifications
Hopping scheme	modes according to standard	Europe (except France), USA France RX/TX single frequency Reduced hopping

Power meter (frequency-selective) and power versus time

Measurement bandwidth	filter definition: passband	
	<i>Filter Bandwidth</i> → wide <i>Filter Bandwidth</i> → narrow	2.0 MHz 1.3 MHz
Reference level for full dynamic range	GFSK signal	
RF 1		0 dBm to +41 dBm
RF 2		-14 dBm to +33 dBm
RF 4 IN		-32 dBm to 0 dBm
Dynamic range	<i>Filter Bandwidth</i> → wide	>55 dB, rms
Level uncertainty	in temperature range +20 °C to +35 °C	
RF 1, RF 2	from full scale setting down to -25 dB	<0.7 dB
RF 4 IN	from full scale setting down to -25 dB	<0.9 dB
Level uncertainty	in temperature range +5 °C to +45 °C	
RF1, RF2	from full scale setting down to -25 dB	<1.0 dB
RF4IN	from full scale setting down to -25 dB	<1.1 dB
Level resolution	in manual mode in remote control mode	0.1 dB 0.01 dB

Modulation analyzer

Measurement bandwidth	filter definition: passband	
	<i>Filter Bandwidth</i> → wide <i>Filter Bandwidth</i> → narrow	2.0 MHz 1.3 MHz
Level range	GFSK signal	
RF 1, RF 2, RF 4 IN		from full scale setting down to -25 dB
Total measurement range for frequency offset and frequency deviation		-250 kHz to +250 kHz
Frequency offset uncertainty in preamble	for deviation ≤160 kHz	≤2 kHz

Frequency deviation uncertainty in payload	for 100 kHz < deviation ≤ 200 kHz	
	11110000 pattern	≤2 %
	10101010 pattern	≤4 %

Frequency drift uncertainty	measured in burst related to frequency offset value in preamble	
	10101010 pattern maximum typically	≤2 kHz ≤1 kHz

Frequency resolution	in manual mode in remote control mode	1 kHz 1 Hz
-----------------------------	--	---------------

Timing measurement

Range		±20 μs
Resolution		≤0.25 μs
Uncertainty		≤0.25 μs + resolution

Speech codec

Speech decoder output	SPEECH HANDSET OUT	9-pin sub-D connector
Output impedance		<10 Ω
Maximum output current		20 mA, peak
Full-range output level		1 V, peak

Speech coder input	SPEECH HANDSET IN	9-pin sub-D connector
Input impedance		100 kΩ
Full-range input level	low sensitivity high sensitivity	1.4 V, peak 0.1 V, peak

Option I/Q/IF Interface R&S CMU-B17

I/Q interface

Analog I/Q outputs	IF → I/Q; TX and RX paths, analog I/Q output	connector I/Q CH1
I/Q bandwidth		0 MHz to 2.5 MHz
Max. output voltage range	EMF	-1 V to +1 V, peak $\sqrt{I^2 + Q^2} = 1$ V, peak
Output impedance		50 Ω
I and Q amplitude imbalance	for WCDMA function group	<2 % <2.5 %
Offset voltage	in temperature range +20 °C to +35 °C in temperature range +20 °C to +35 °C for WCDMA function group in temperature range +5 °C to +45 °C	<4 mV <5 mV <8 mV

Analog I/Q inputs	I/Q → IF; TX-path, analog I/Q input	connector I/Q CH1
I/Q bandwidth		0 MHz to 2.5 MHz
Max. input voltage range		-0.5 V to +0.5 V, peak $\sqrt{I^2 + Q^2} = 0.5$ V, peak
Input impedance		50 Ω
Carrier suppression	in temperature range +20 °C to +35 °C in temperature range +5 °C to +45 °C	>40 dB >35 dB
Sideband suppression	$f_{I/Q} < 1$ MHz 1 MHz < $f_{I/Q} < 2.5$ MHz	>45 dB >40 dB

Analog I/Q inputs	I/Q → IF; RX path, analog I/Q input	connector I/Q CH1
I/Q bandwidth		0 MHz to 2.5 MHz
Max. input voltage range		-0.5 V to +0.5 V, peak $\sqrt{I^2 + Q^2} = 0.5$ V, peak
Input impedance		50 Ω
Carrier suppression	in temperature range +20 °C to +35 °C in temperature range +5 °C to +45 °C	>35 dB ⁹ >35 dB ⁹
Sideband suppression	$f_{I/Q} < 1$ MHz 1 MHz < $f_{I/Q} < 2.5$ MHz	>45 dB >40 dB

Influence on RF interface

GSM/EDGE measurements		
Additional influence on signal quality	analog I/Q input and output considered; for TX and RX paths	
Phase error	GMSK	<3°, peak <1°, rms
EVM	8PSK	<5 %, rms

WCDMA measurements	3GPP FDD, UE test	
Additional influence on signal quality	analog I/Q input and output considered; for TX and RX paths	
EVM		<5 %, rms

⁹ For GMSK modulation and max. input voltage at I/Q inputs.

RF level uncertainty	bypass with I/Q IF OUT, I/Q IN/OUT, IF IN/OUT	
Output level uncertainty	at RF 1, RF 2, RF 3 OUT	add 0.3 dB to R&S CMU200 base unit specifications
Input level uncertainty of frequency-selective power meter	at RF 1, RF 2, RF 4 IN	add 0.3 dB to R&S CMU200 base unit specifications

IF interface

IF inputs, TX path		connector IF3 TX CH1 IN
IF level range		up to -5 dBm, PEP
Standard IF frequencies	RF/GSM (GMSK and 8PSK)/ TDMA/cdma2000 WCDMA	13.85 MHz 15.36 MHz

IF inputs, RX path		connector IF3 RX CH1 IN
IF level range		up to +2 dBm, PEP
Standard IF frequencies	RF/GSM (GMSK and 8PSK)/ TDMA/cdma2000 WCDMA	10.7 MHz 7.68 MHz

IF outputs, TX path		connector IF3 TX CH1 OUT
IF level range		up to -5 dBm, PEP
Standard IF frequencies	RF/GSM (GMSK and 8PSK)/ TDMA/cdma2000 WCDMA	13.85 MHz 15.36 MHz

IF outputs, RX path		connector IF3 RX CH1 OUT
IF level range		up to +6 dBm, PEP
Standard IF frequencies	RF/GSM (GMSK and 8PSK)/ TDMA/cdma2000 WCDMA	10.7 MHz 7.68 MHz

Remarks

- Due to the modulation schemes used Bluetooth and AMPS standards will not be supported.
- The options R&S CMU-B17 and R&S CMU-B73 use the same mainboard connector of the R&S CMU200. Therefore either the R&S CMU-B17 or the R&S CMU-B73 can be ordered for a single instrument.

Additional information for GSM:

To avoid influences on the fading profile, the following is highly recommended:

- To set all timeslots to the same level.
- To use for the TX signal of the R&S CMU200 the same RF frequencies and RF levels for both TCH and BCCH.
- To switch hopping off.

Aspects to be considered if TX or RX signal paths are interrupted:

The RF frequency of the R&S CMU200 influences the rotating direction of the I/Q vector. The direction is inverted for $f < 1200.1$ MHz; this can be compensated for by changing I and Q.

	R&S CMU200 generator or analyzer RF frequency	
	100 kHz to 1200.0999999 MHz	1200.1 MHz to 2700.0 MHz
R&S CMU200 I/Q output vector	inverted rotation swap I output with Q output for proper operation	normal rotation
R&S CMU200 I/Q input vector	inverted rotation swap I input with Q input for proper operation	normal rotation

The rotating direction must be considered if the R&S CMU200 signal path from the link handler board to the frontend and vice versa is interrupted, i.e. if the signal is not returned to the same R&S CMU200 block after external handling.

Examples:

- The rotating direction must **not** be taken into account if the transmitted signal is routed from the I/Q output of the R&S CMU-B17 to an external fading simulator and then returned to the R&S CMU200 I/Q input (the R&S CMU200 in combination with the Fading Simulator R&S ABFS or R&S SMIQ/SMIQB14, the R&S CMU200 providing the faded RF signal).
- The rotating direction must be considered if the transmitted signal is forwarded to an external fading simulator and is not returned to the I/Q input of the R&S CMU200 (the R&S CMU200 in combination with the R&S SMIQ, the R&S SMIQ providing the faded RF signal).

Notes for measuring I/Q/IF signals applied to inputs of the R&S CMU-B17 option on the R&S CMU200 RX path:

- The RF spectrum analyzer function (RF function group) cannot be used.
- The displayed RF power levels are not related directly to the applied I/Q/IF voltages. The analyzer settings of the R&S CMU200 RF interface (RF 1, RF 2, RF 4 IN) have to be considered additionally (*Analyzer Level* → *RF Max. Level*).
- I/Q inputs have a fixed attenuation of 2 dB; e.g. the RF power meter readout for an applied 500 mV I/Q peak voltage will be 2 dB below the value set in *RF Max. Level*.
- IF inputs do not have a fixed attenuation. The max. IF input level is 2 dBm. The RF power meter readout for the mentioned max. IF signal level (2 dBm) will be 2 dB below the value set in *RF Max. Level*.
- We recommend switching off the autoranging function.
- RF and IF trigger functions are not possible.
- The WCDMA RF compensation filter is switched off (I/Q IN/OUT, IF IN/OUT, IFIN_I/Q IN/OUT).
- WCDMA UE test: ACLR/SEM measurement is not applicable.

Option Audio Generator/Analyzer R&S CMU-B41

AF generator

Output impedance		<4 Ω
------------------	--	-------------

Maximum output current		20 mA, peak
------------------------	--	-------------

AF sine generator		
Frequency range		20 Hz to 20 kHz
Frequency uncertainty		same as time base + half resolution, see base unit specifications
Frequency resolution		0.1 Hz
Output level range		10 μ V to 5 V
Output level resolution	at level <10 mV at level \geq 10 mV	10 μ V 0.1 %
Output level uncertainty	at level \geq 1 mV and frequency \leq 10 kHz	\leq 1.5 % + resolution
THD+N ¹⁰	at level \geq 100 mV into load \geq 600 Ω	\leq 0.05 %
THD ¹⁰	at level \geq 100 mV into load \geq 600 Ω	\leq 0.025 %

AF analyzer

Input impedance		1 M Ω 100 pF
-----------------	--	------------------------

AF voltmeter		
Frequency range		50 Hz to 20 kHz
Level range		50 μ V to 30 V
Level resolution	at level <1 mV at level \geq 1 mV	1 μ V 0.1 %
Level uncertainty	at 1 mV \leq level \leq 2 V at 2 V < level \leq 20 V	<1 % + resolution <2 % + resolution

THD+N meter		
Measurement bandwidth		21 kHz
Frequency range		100 Hz to 10 kHz
Level range		10 mV to 30 V
Resolution		0.01 % THD+N
Inherent distortion	at 100 mV \leq level \leq 20 V	<0.05 % THD+N
Uncertainty	at 100 mV \leq level \leq 2 V at 2 V < level \leq 20 V	<1 % + inherent resolution <2 % + inherent resolution

Option RF1 Level Range Identical to RF2 R&S CMU-U99/B99

With the R&S CMU-U99/B99 installed, the input/output level range and the input/output level uncertainty for RF 1 are the same as for RF 2.

With the R&S CMU-U99/B99 installed, the VSWR of the RF generator and analyzer at RF 1 is as follows:

VSWR	RF generator and RF analyzer	
RF1	10 MHz to 2000 MHz 2000 MHz to 2200 MHz 2200 MHz to 2700 MHz	<1.2 <1.4 <1.6

¹⁰ Measurement bandwidth 21.9 kHz

The specifications for the R&S CMU200 (Order No. 1100.0008.02) refer to a fully equipped unit with all options installed.

Specifications are valid under the following conditions:

Data without tolerance limits is not binding.

In compliance with the 3GPP/3GPP2 standard, chip rates are specified in Mcps (million chips per second), whereas bit rates and symbol rates are specified in kbps (thousand bits per second) or ksps (thousand symbols per second).

Mcps, kbps and ksps are not SI units.

For more general information about the R&S CMU200 please refer to the product brochure PD 0758.0039.12, version 06.00.



Product brochure see PD 0758.0039.12
and at www.rohde-schwarz.com
(search term: CMU)



ROHDE & SCHWARZ

www.rohde-schwarz.com