

Acoustic Measurements

on
TDMA Mobile Phones
with
CMU200



The acoustic transmission and reproduction quality of mobile phones is its most important characteristic in every-day use.

The most visually appealing design or a wonderfully sophisticated means of operation are not much use when the enduser hardly understand what is being said at the other end.

Instruments and procedures for measuring acoustic characteristics are therefore essential tools for determining the quality and suitability of a mobile phone.

Products involved

Hardware

Audio Generator and Analyzer	CMU-B41
Speech Codec	CMU-B52
Signaling Unit	CMU-B21

Software (at least one of the following)

Software IS-136/Cellular (800MHz)	CMU-K27
Software IS-136/PCS (1900MHz)	CMU-K28

based on sw V3.00 and higher

The option *Audio Generator and Analyzer CMU-B41* also includes the Multitone measurement feature.

For a description of the features refer to chapter 4 of CMU Operating Manual, Id.No. 1100.4903.12 .

The option *Speech Codec CMU-B52* contains the ACELP voice codec.

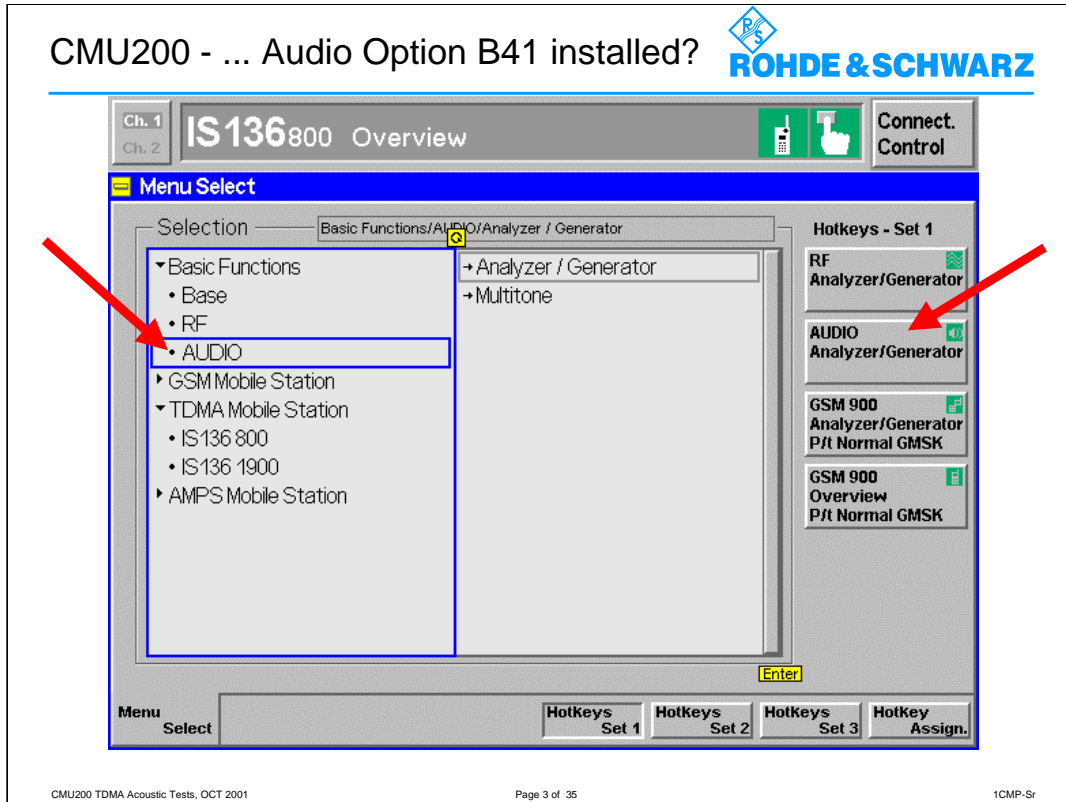

The option *Audio Generator and Analyzer CMU-B41* also includes the Multitone measurement feature.

The Audio option *CMU-B41* is a *Basic Functions* feature.

This means it can be used network **independent**.

Audio Generator and Analyzer Option CMU-B41

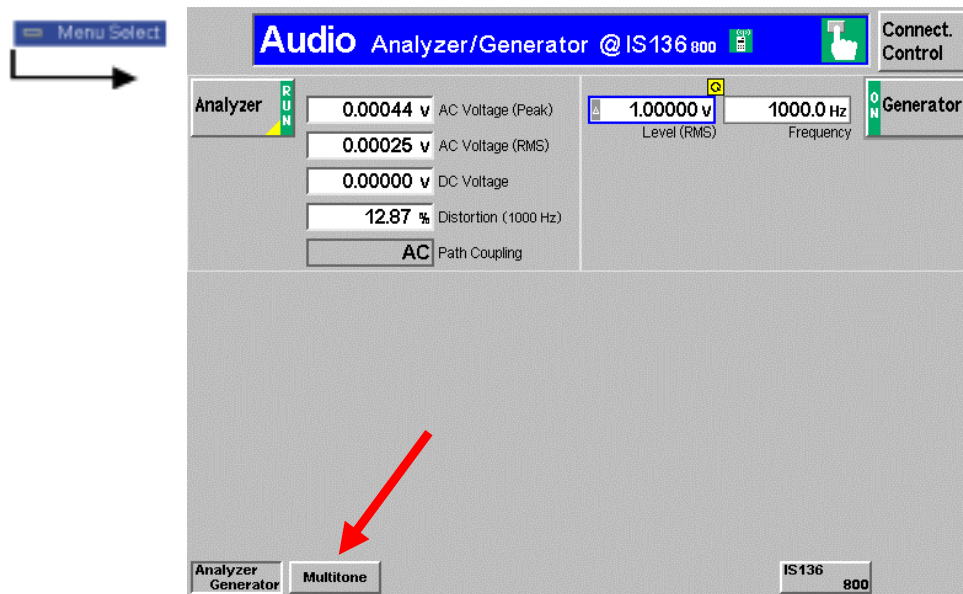

CMU200 TDMA Acoustic Tests, OCT 2001

Page 4 of 35

1CMP-Sr

The main menu *Analyzer/Generator* defines the sinusoidal signal generated by the audio generator and displays the voltage of the measured audio signal.

The *Analyzer/Generator* menu is opened from the main menu *Menu Select* (with associated key at front of instrument) or via the *Audio* hotkey which is available in all *IS-136* measurement menus. Compared to the standalone case, the latter option offers an extended functionality.

Standalone *audio* measurements are performed with default connector settings, the audio signals being applied to the connectors *AF IN* (input) and *AF OUT* (output) on the front panel of CMU.

If *Audio* is used in the context of *IS-136* measurements, the *AF/RF*

tab of the associated *Connect. Control* menu allows to select the input source of the CMU speech encoder and the output destination of its speech decoder.

Note:

In addition to the features reported in this section, option CMU-B41 offers some extended functionality that is accessible via remote control only:

- Secondary audio circuit; analogous to the primary circuit
- Variable band pass filter
- Frequency counter 10Hz ... 204.8kHz

For a description of the additional features refer to chapter 6 of CMU Operating Manual, Id.No. 1100.4903.12 .

How to test the Speech Codec of a mobile phone

with

Speech Codec Option CMU-B52 and

with or without

Audio Generator and Analyzer Option CMU-B41

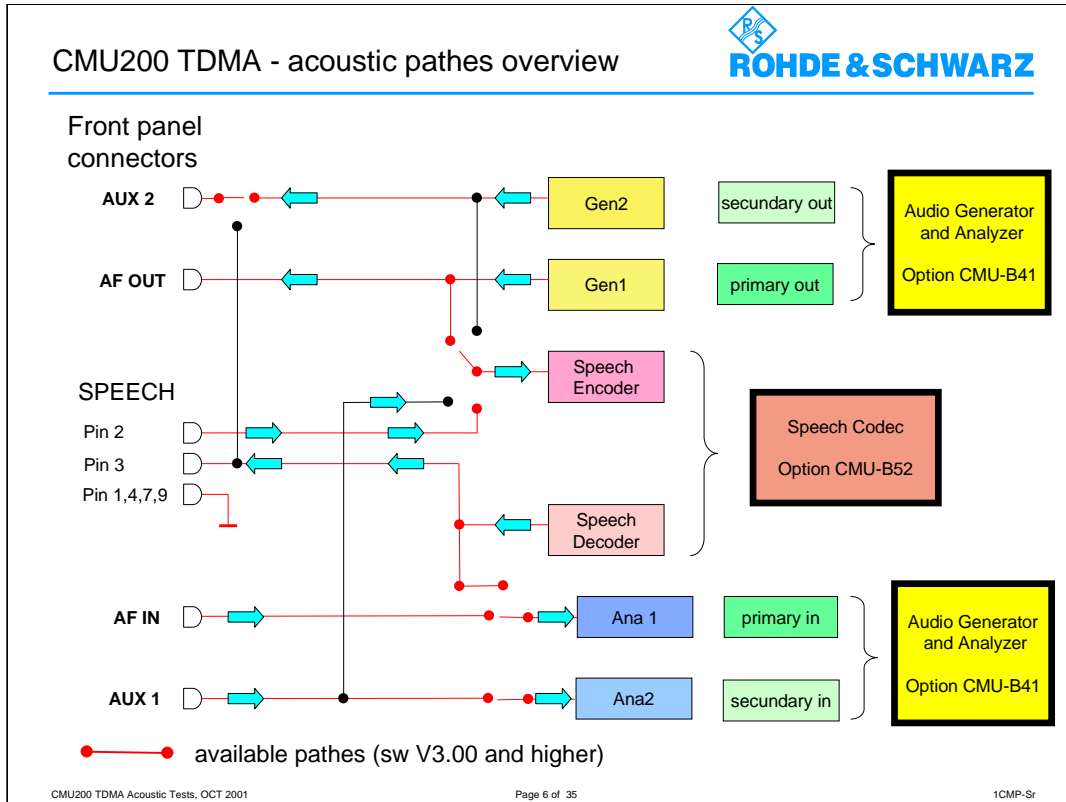

The am. schematic shows (red marked) the currently available acoustic paths if the options Audio Generator and Analyzer CMU-B41 and Speech Codec CMU-B52 are installed.

The *Audio* measurement is divided into the two subsystems for AF Generator and AF Analyzer control.

In **remote control**, two independent circuits are provided:-

- In the primary audio circuit, the audio signals are applied to the connectors AF OUT (output, AF generator signal) and AF IN (input) on the CMU front panel. The primary audio circuit corresponds to the *Audio Analyzer/Generator* menu and the associated configuration menu.
- In the secondary audio circuit, the audio signals are applied to the connectors AUX 2 (output, AF generator signal) and AUX 1 (input) on the CMU front panel.

The secondary audio circuit can not be controlled manually with sw versions less than V3.05.

Beginning with sw V3.05 also the secondary audio circuit can be used manually for Multitone measurements.

With the exception of the input and output connectors, the two audio circuits are identical. All remote control commands are analogous.

(1) Acoustic measurements on TDMA mobiles

with

Speech Codec Option CMU-B52

and with

Audio Generator and Analyzer Option CMU-B41

This application is used to perform a subjective quality check of the mice and earphone of a mobile phone.

Special problems are encountered when measuring acoustic characteristics caused by the TDMA encoder and decoder algorithms.

In commercial mobiles measurements during normal operation can only be performed via the air-interface with the voice encoder and decoder included.

A so-called vocoder is used to attain the lowest possible data rate, only the filter and fundamental parameters required for signal reconstruction are transmitted, not the actual voice.

The audio generator of option CMU-B41 uses sinwave tones that cover some restrictions on the results measured:

Measurements using sin tones cannot be performed because the static sinwave input signal becomes a more or less stochastic output signal as a result of coding, particularly in the medium and high audio frequency ranges. If, for instance, a tone of approx 2.5 2.7kHz is applied to the mobile phone with a constant sound pressure, the amplitude of the signal obtained at the decoder output varies by approx 20dB which makes the signal unsuitable for measurements.

With frequencies up to slightly above 1kHz the sinwave tone is transmitted with sufficient stability to allow common distortion measurements to be performed at 1kHz using a sinewave signal.

Acoustic tests with Speech Codec option CMU-B52

Where do I find the parameter settings?	Menu Location ?
What do these parameters mean?	Functions ?
When are they available?	Signaling Status ?

Various so-called *Speech Mode* parameters are involving the CMU speech codec, option *CMU-B52*.

The various parameter settings are supported in the corresponding network, eg. *TDMA (IS-136) Software CMU-K27*.

A good guideline is the Operating Manual for *TDMA (IS-136) Software* (Id.No. 1115.6688.12), chapter 4, part *Signalling: Connection Control*.

CMU TDMA - Acoustic Tests

Acoustic tests with Speech Codec option CMU-B52

Where do I find the parameter settings?

see (1) *BS Signal Parameters (State Signal Off/On, Registered)*

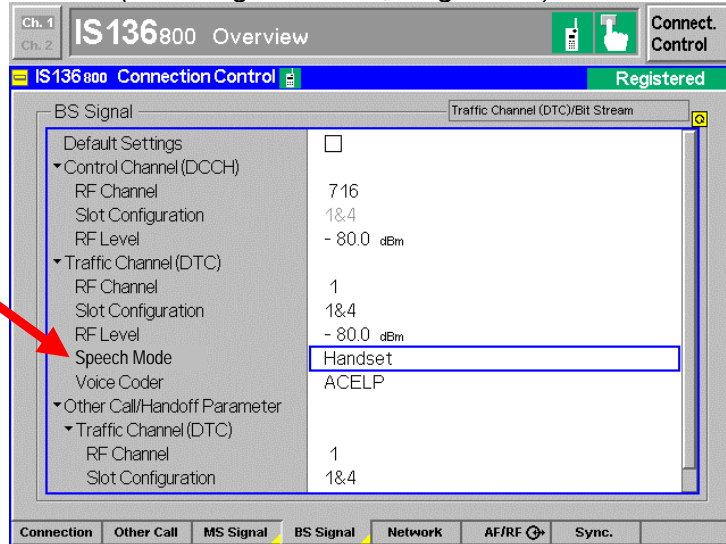

CMU200 TDMA Acoustic Tests, OCT 2001

Page 9 of 35

1CMP-Sr

The *BS Signal* tab configures the signals of the CMU.

This includes the selection of the transmit data, so-called *Speech Mode*.

The *Speech Mode* determines the data transmitted over the traffic channel and the signal path to the mobile.

CMU TDMA - Acoustic Tests

Acoustic tests with option CMU-B52

Where do I find the parameter settings?

see (2) *BS Signal Parameters (State Call Established)*

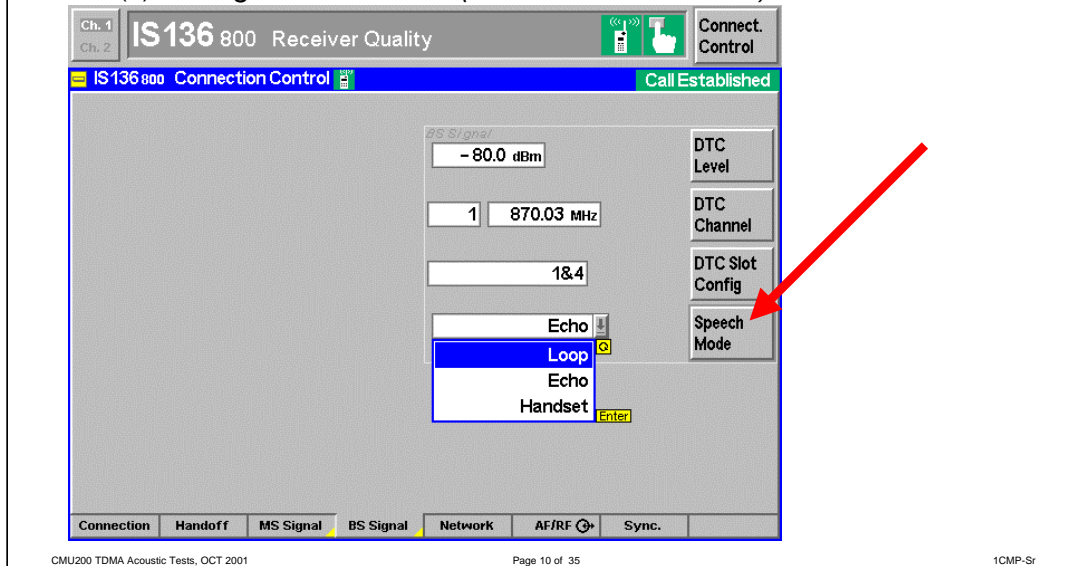

The *BS Signal* tab configures the signals of the CMU.

This includes the selection of the transmit data, so-called *Speech Mode*.

The *Speech Mode* determines the data transmitted over the traffic channel and the signal path to the mobile.

For acoustic tests you can choose between the following mode settings:

- *Handset*
- *Echo*
- *Loop*

The test setting *Handset* can be performed with an Audio Analyzer.

CMU TDMA - Acoustic Tests



Acoustic tests with option CMU-B52

What do these parameters mean?

Handset

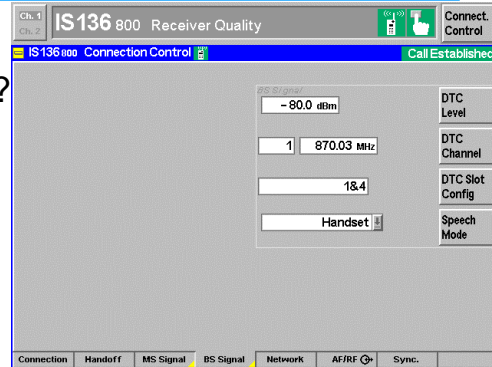

The CMU sends and receives speech frames that are routed to the internal speech codec on option board CMU-B52.

The *Speech Mode* determines the data transmitted over the traffic channel and the signal path to the mobile.

Analog signals are provided via the front panel connector *SPEECH*.

The analog input signal at connector *SPEECH* is amplified by 22.5dB.

The pin assignment of *SPEECH* connector is shown on a later page.

The mostly used setting

Handset mode

in detail

Audio Uplink

- Bitstream mode setting "Handset"
- setting "Speech Encoder to Handset" (A)
- setting "Speech Decoder to Analyzer" (B)

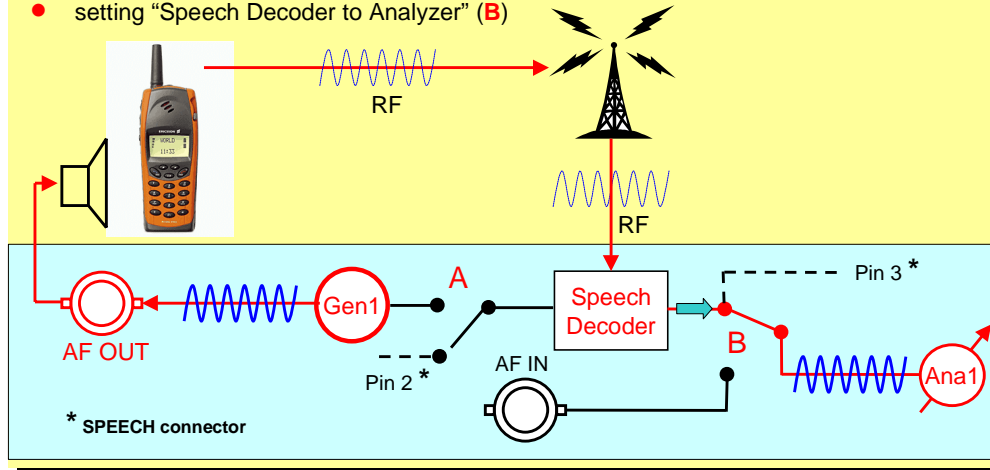

CMU200 TDMA Acoustic Tests, OCT 2001

Page 13 of 35

1CMP-Sr

The AF/RF \leftrightarrow tab (function group *IS136* or *Signalling* mode) configures for instance the connectors for AF signals.

This includes the setting of the input source of the CMU speech encoder and the output destination of its speech decoder.

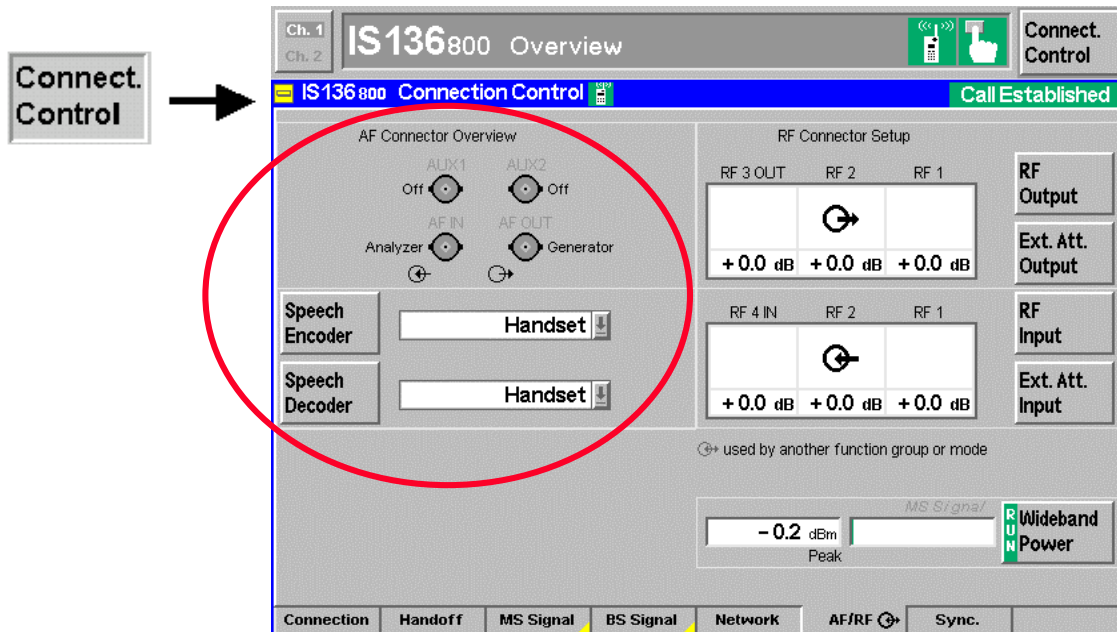

If the *Audio Generator and Analyzer* (option CMU-B41) is not fitted, the speech codec (option CMU-B52) is connected to the 9-pole *SPEECH* (handset) connector on the CMU front panel, see chapter 8 of the CMU200 Operating Manual, Id.No. 1100.4903.12 .

CMU TDMA - Audio Pathes "Handset"

Front panel connectors

Audio Uplink

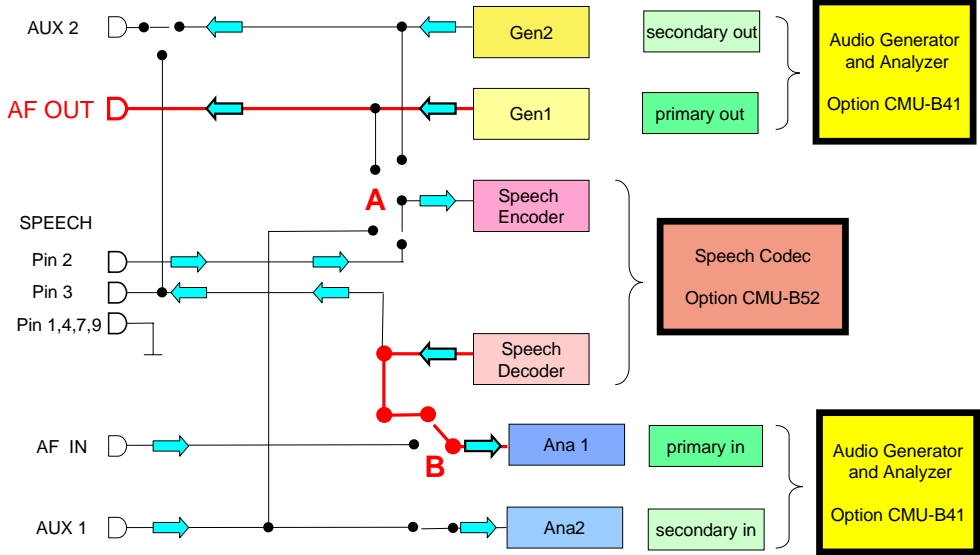

Audio Downlink

- Bitstream mode setting "Handset"
- setting "Speech Encoder to Generator" (A')
- setting "Speech Decoder to Handset" (B')

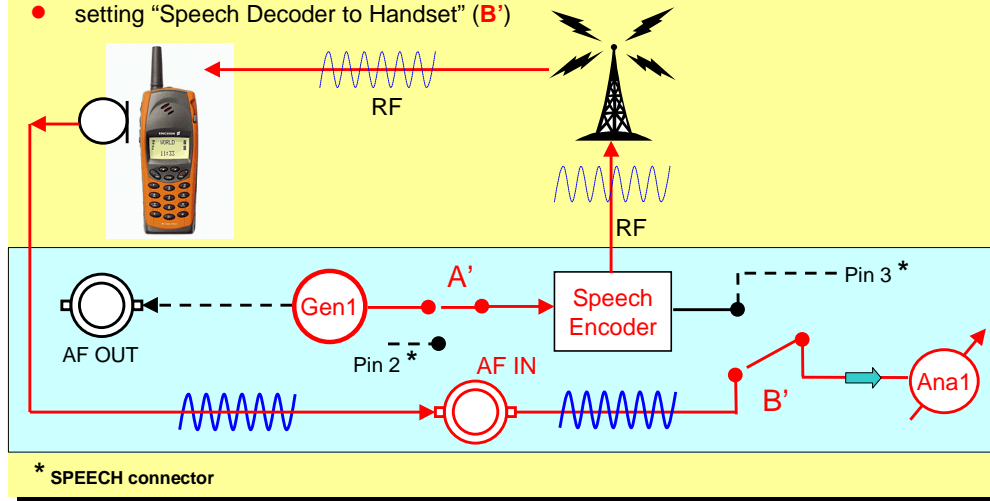

* SPEECH connector

CMU TDMA - Audio Pathes "Handset"

Front panel connectors

Audio Downlink

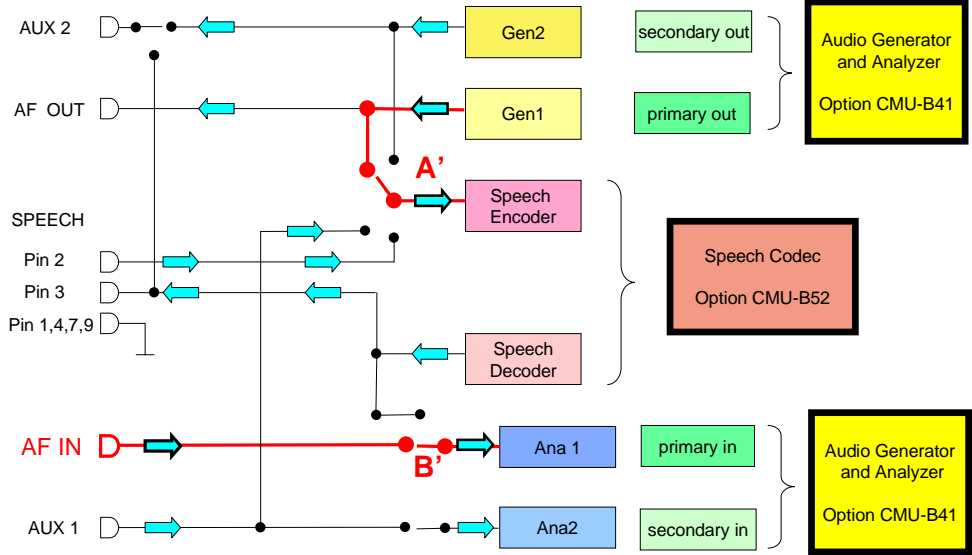

AF generator

Output impedance <math><4 \Omega</math>
 Maximum output current 20 mA

AF sine generator

Frequency range 20 Hz to 20 kHz
 Frequency uncertainty same as time base + half resolution
 Frequency resolution 0.1 Hz
 Output level range 10 μ V to 5 V
 Output level resolution
 at level <math><10 \text{ mV}</math> 10 μ V
 at level $\geq 10 \text{ mV}</math> 0.1%
 Output level uncertainty
 at level $\geq 1 \text{ mV}$ and frequency $\leq 10 \text{ kHz}</math> $\leq 1.5\% + \text{resolution}</math>$$$

THD+N¹⁾
 at level $\geq 100 \text{ mV}$ into load $\geq 600 \Omega$ $\leq 0.05\%$

THD¹⁾
 at level $\geq 100 \text{ mV}$ into load $\geq 600 \Omega$ $\leq 0.025\%$

¹⁾ Measurement bandwidth: 21.9 kHz

AF analyzer

Input impedance 1M Ω || 100 pF

AF voltmeter

Frequency range 50 Hz to 20 kHz

Level Range 50 μ V to 30 V

Level Resolution

at level <1 mV 1 μ V

at level \geq 1 mV 0.1%

Level uncertainty

at 1 mV \leq level \leq 2 V <1.0% + resolution

at 2 V < level \leq 20 V <2.0% + resolution

THD+N meter

Measurement bandwidth 21 kHz

Frequency range 100 Hz to 10 kHz

Level Range 10 mV to 30 V

Resolution 0.01% THD+N

Inherent distortion

at 100 mV \leq level \leq 20 V <0.05% THD+N

Uncertainty

at 100 mV \leq level \leq 2 V <1% + inherent distortion

at 2 V < level \leq 20 V <2% + inherent distortion

Subsystem AFAnalyzer...:FILTer (Filter)

The subsystem *AFAnalyzer:...:FILTer* contains the commands for the configuration of the audio analysis filter. The input path of the AF analyzer is as shown below:

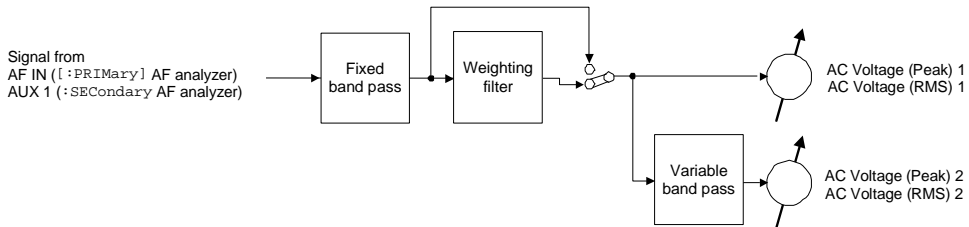

Fig. 6-1 AF analyzer input path configuration

Note: This subsystem has no equivalent in manual control.

Weighting Filter commands:

CONFigure:AFAnalyzer[:PRIMary]:FILTer:WEIGHting <Weighting>
CONFigure:AFAnalyzer:SECOndary:FILTer:WEIGHting <Weighting>>

- <Weighting>** Description of parameters
- CME |** Switch on C-message weighted filter
- CCI |** Switch on CCITT weighting filter
- OFF** No weighting filter

These commands select the weighting filter after the fixed band pass.

AF Analyzer filter config - IEEE bus



Audio Generator and Analyzer (with Option CMU-B41)

CMU

CONFigure:AFANalyzer[:PRIMary]:FILTer:VBPass:CFrequency <Center>		Frequency		
<Frequency>	Description of parameters	Def. value	Def. unit	Unit ring
20 Hz to 20000 Hz	Center frequency of band pass	1000	Hz	
Description of command				FW vers.
This command determines the center frequency of the variable band pass.				≥ V2.12

CONFigure:AFANalyzer[:PRIMary]:FILTer:VBPass:BWIDth <Bandwidth>		Bandwidth		
<Frequency>	Description of parameters	Def. value	Def. unit	Unit ring
10 Hz to 1000 Hz	Bandwidth of band pass	200	Hz	
Description of command				FW vers.
This command determines the 3 dB bandwidth of the variable band pass.				≥ V2.12

CONFigure:AFANalyzer[:PRIMary]:FILTer:WEIGHting <Weighting>		Weighting Filter		
<Weighting>	Description of parameters	Def. value	Def. unit	Unit ring
CME	Switch on C-message weighted filter	OFF	-	Freq.
CCI	Switch on CCITT weighting filter			
OFF	No weighting filter			
Description of command				FW vers.
This command selects the weighting filter after the fixed band pass (see Fig. 6-1).				≥ V2.12

AF Analyzer filter config - IEEE bus



CONFigure:AFANalyzer[:PRIMary]:FILTer:BPASs <Band pass>		Fixed Band Pass Selection		
CONFigure:AFANalyzer:SECOndary:FILTer:BPASs <Band pass> >		Def. value	Def. unit	Unit ring
<Band pass>	Description of parameters			
BP01	CMU band pass filter with a 3 dB bandwidth of	BP16	-	
BP02	0 Hz to 250 Hz			
BP03	6 Hz to 250 Hz			
BP04	50 Hz to 250 Hz			
BP05	0 Hz to 3000 Hz			
BP06	6 Hz to 3000 Hz			
BP07	50 Hz to 3000 Hz			
BP08	300 Hz to 3000 Hz			
BP09	0 Hz to 4000 Hz			
BP10	6 Hz to 4000 Hz			
BP11	50 Hz to 4000 Hz			
BP12	300 Hz to 4000 Hz			
BP13	0 Hz to 15000 Hz			
BP14	6 Hz to 15000 Hz			
BP15	50 Hz to 15000 Hz			
BP16	300 Hz to 15000 Hz			
BP17	0 Hz to 21000 Hz			
BP18	6 Hz to 21000 Hz			
	50 Hz to 21000 Hz			
Description of command				FW vers.
This command selects the first band pass in the AF Analyzer.				≥ V2.12

(2) Acoustic measurements on TDMA mobiles

with

Speech Codec Option CMU-B52

but without

Audio Generator and Analyzer Option CMU-B41

This application is used in type approval tests where highly accurate measurements are required.

Trade journals, consumer test institutes or network operators are particularly interested in measuring and comparing acoustic characteristics of mobile phones. Network operators for instance must be able to check customer complaints or test the quality of supplied phones. A highly accurate test method is also required in the quality assurance of mobiles and for sampling inspection in production facilities.

The typical test setup is performed in combination with an audio test system.

These highly accurate acoustic measurements do **not** require the option Audio Generator and Analyzer CMU-B41.

If the *Audio Generator and Analyzer* option CMU-B41 is not fitted, the speech codec option CMU-B52 is connected to the 9-pole *SPEECH* (handset) connector on the CMU front panel.

CMU TDMA - Acoustic Paths

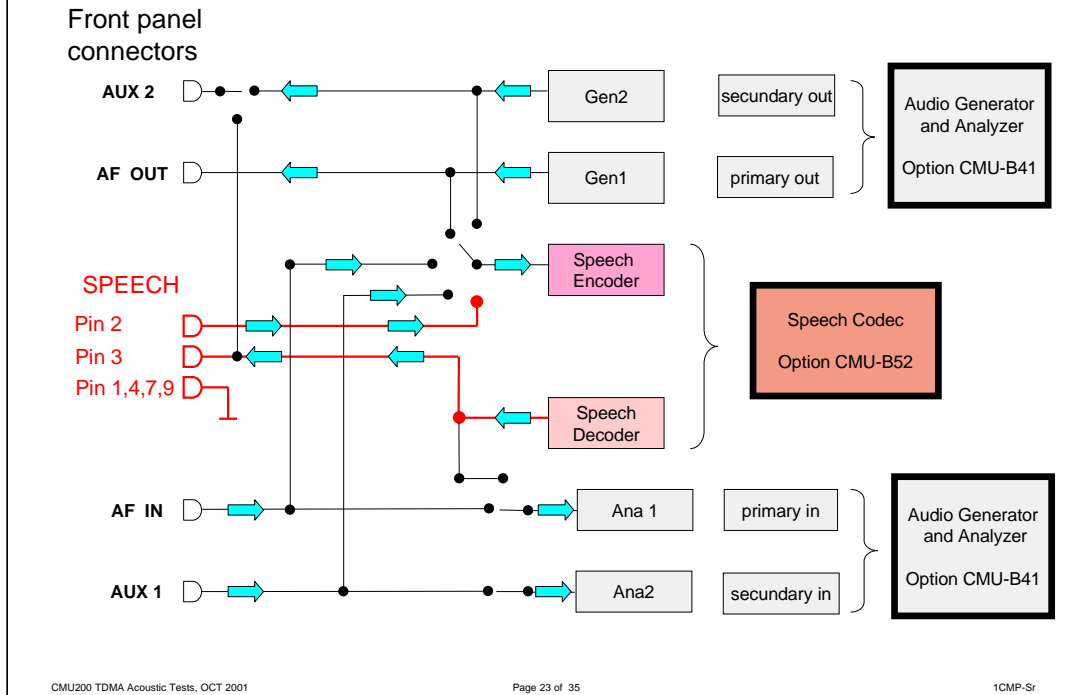

A typical test setup is performed in combination with an audio test system with corresponding options and accessories.

Such an Audio Analyzer is connected to the CMU200 at the frontpanel connector SPEECH at its corresponding contacts.

The TDMA test mobile is driven by CMU200 via the air-interface, connected through the relevant RF frontpanel connector. CMU200 simulates a base station so that a call can be setup.

Two test paths have to be considered.

In Uplink direction (sending direction):

acoustic input of mobile under test (microphone) to decoder output (pin 3)

In Downlink direction (receiving direction):

encoder input (pin 2) to acoustic output of mobile under test (speaker)

Acoustic devices such as an artificial mouth, artificial ear and other accessories are required for these measurements.

Pin Assignment

Pin 1,4,7,9	Ground	
Pin2	Handset In	for Signaling Unit CMU-B21
Pin 3	Handset Out	for Signaling Unit CMU-B21
Pin 5	Handset In	for 2nd Signaling Unit CMU-B21 or CDMA Signaling Unit for TDMA
Pin 6	Handset Out	for 2nd Signalling Unit CMU-B21 or CDMA Signaling Unit for TDMA
Pin 8	Power Supply	+5VDC, max 100mA

see chapter 8 of the CMU200 Operating Manual, Id.No. 1100.4903.12 :

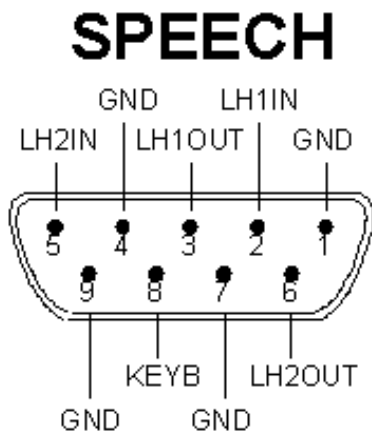

Levels in mode setting „Handset“

The following RMS levels correspond to the 0dBm0 level.

Input level (Pin 2):

using an external generator 0.05 Vrms

using the internal generator (option CMU-B41) 0.5 Vrms

Output level (Pin 3): 0.5 Vrms

The given levels may vary approx 10% in both directions depending on the AD/DA converter used by the speech coder.

Levels in mode setting „Handset“

Full scale levels

Full scale is defined as 3.14dBm0.

Therefore the maximum input and output levels are:-

Full scale input level (Pin 2):

using an external generator	0.072 Vrms
using the internal generator (option CMU-B41)	0.72 Vrms

Full scale output level (Pin 3):	0.72 Vrms
----------------------------------	-----------

The given levels may vary approx 10% in both directions depending on the AD/DA converter used by the speech coder.

Impedances in mode setting „Handset“

Input Impedance (Pin 2) 100 kOhm

Output Impedance (Pin 3) 10 Ohm

(3) Acoustic measurements at mobile phones

with

Audio Generator and Analyzer Option CMU-B41

and its

Multitone Functionality

This application is used to perform a subjective quality check of the mice and earphone of a mobile phone.

Special problems are encountered when measuring acoustic characteristics caused by the TDMA encoder and decoder algorithms.

In commercial mobiles measurements during normal operation can only be performed via the air-interface with the voice encoder and decoder included.

A so-called vocoder is used to attain the lowest possible data rate, only the filter and fundamental parameters required for signal reconstruction are transmitted, not the actual voice.

The audio generator of option CMU-B41 uses sinwave tones that cover some restrictions on the results measured:

Measurements using sin tones cannot be performed because the static sinwave input signal becomes a more or less stochastic output signal as a result of coding, particularly in the medium and high audio frequency ranges. If, for instance, a tone of approx 2.5 2.7kHz is applied to the mobile phone with a constant sound pressure, the amplitude of the signal obtained at the decoder output varies by approx 20dB which makes the signal unsuitable for measurements.

With frequencies up to slightly above 1kHz the sinwave tone is transmitted with sufficient stability to allow common distortion measurements to be performed at 1kHz using a sinewave signal.

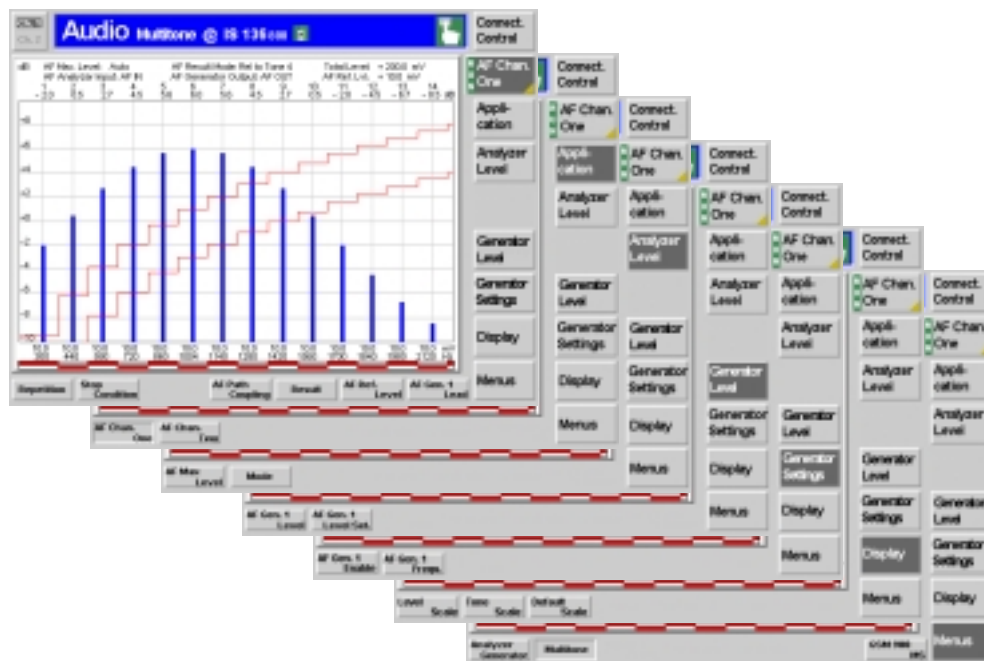

CMU200 TDMA Acoustic Tests, OCT 2001

Page 29 of 35

1CMP-Sr

The graphical measurement menu *Multitone* shows the results of the multitone audio measurement.

To perform an *Multitone* measurement, the CMU generates a composite audio signal that represents the superposition of up to 20 individual fixed-frequency tones with configurable frequency and level. An audio signal containing the same tones can be analyzed in a single measurement and displayed in a bar chart.

The *Multitone* measurement is thus a fast method to determine the level of up to 20 different tones at known frequencies and to perform a limit check for all results.

Possible applications are also frequency response and intermodulation measurements.

How wide are the setting ranges?

AF Frequency of test tone 10Hz to 15999Hz
 AF Level of test tone 0.0V to 5.0V

Each test tone can be enabled (switched on) or disabled (switched off) individually. Further setting possibilities are described in the manual.

The measurement menu *Multitone* is opened via the main menu *Menu Select* (with the associated key at the front of the instrument) or from the *Analyzer/Generator* menu using the *Multitone* hotkey.

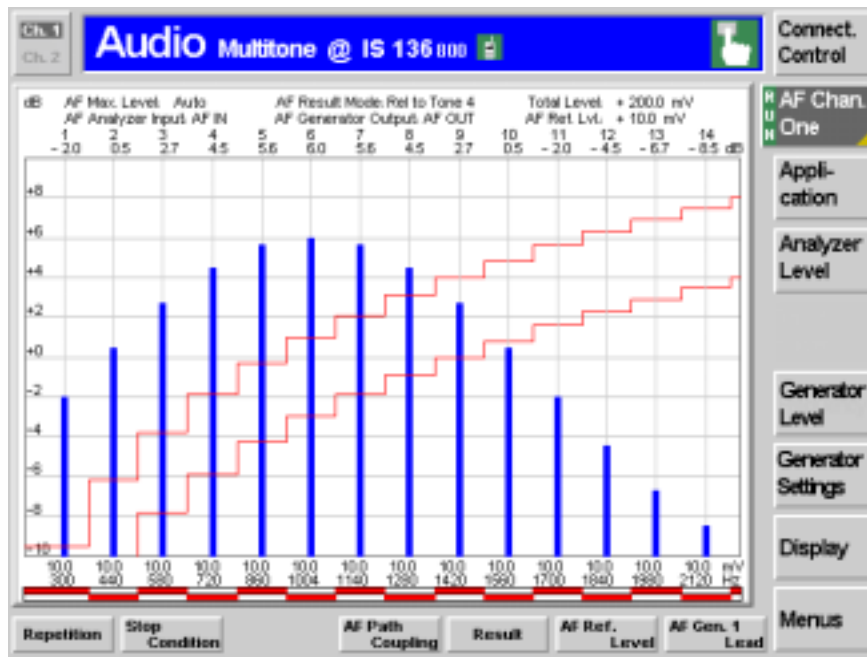

CMU200 TDMA Acoustic Tests, OCT 2001

Page 30 of 35

1CMP-Sr

The subsystem *Multitone* measures the level of an audio test signal comprising up to 20 test tones.

The subsystem corresponds to the measurement menu *Multitone* and the associated popup menu *Multitone Configuration*.

In analogy to the AF Generator and AF Analyzer subsystems explained before, the *Multitone* measurement provides two independent circuits:

- In the first audio channel the audio signals are applied to the connectors AF OUT (output, AF generator signal) and AF IN (input) on the CMU front panel. The first audio channel corresponds to the *Multitone* menu and the associated configuration menu.
- In the second audio channel the audio signals are applied to the connectors AUX 2 (output, AF generator signal) and AUX 1 (input) on the CMU front panel.

The secondary audio circuit can not be controlled manually with sw versions less than V3.05.

Beginning with sw V3.05 also the secondary audio circuit can be used manually for Multitone measurements.

With the exception of the input and output connectors, the two audio circuits are identical. All remote control commands are analogous.

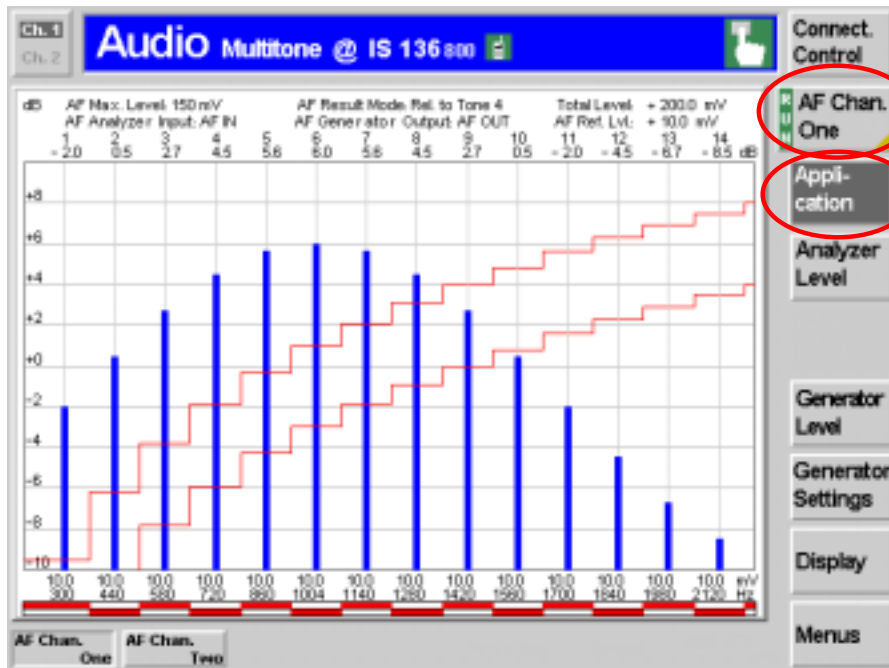

CMU200 TDMA Acoustic Tests, OCT 2001

Page 31 of 35

1CMP-Sr

Application

The *Application* softkey activates one of the applications of the *Multitone* measurement. At present, only one application – *AF Chan. One* – is available.

AF Chan. One

The *AF Chan. One* hotkey selects the *Multitone* measurement on channel one. This means that the audio signals are applied to the connectors AF IN (CMU input) and AF OUT (CMU output) on the front panel. A second audio channel is available in remote control.

Remote control

Audio channel no. one is identified by the third-level keyword AF1Channel.
The second audio channel is identified by AF2Channel.

Path Configuration (TX Tests Configuration – Filter)

The *Filter* tab configures the receive path of the CMU for the *Multitone* measurement.

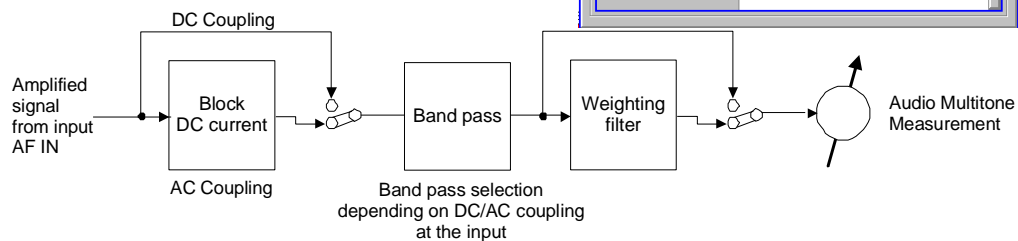
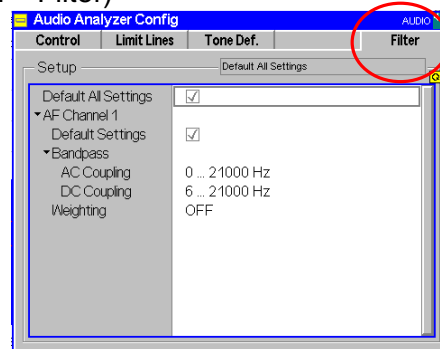

Signal path for Multitone measurements

The *Filter* tab configures the receive path of the CMU for the *Multitone* measurement.

The audio receive path of the CMU may contain the following filter stages:

AF Path Coupling Capacitor stage to block the DC component of the AF input signal including a possible DC offset of the input amplifier. With DC coupling, the complete AF input signal is measured.

Weighting Weighting filter according to CCITT or C-message weighted filter.

Band Pass Audio band pass filter with selectable bandwidth to limit the input frequencies to a definite audio band and eliminate unwanted signal components. The allowed bandwidth depends on the *AF Path Coupling*.

The audio results are generated at the end of the audio receive path, after the audio signal has passed all filter stages that are switched on.

(4) Summary

Products involved

Hardware

Audio Generator and Analyzer	CMU-B41
Speech Codec	CMU-B52
Signaling Unit	CMU-B21

Software (at least one of the following ones)

Software IS-136/Cellular (800MHz)	CMU-K27
Software IS-136/PCS (1900MHz)	CMU-K28

based on sw V3.00 and higher

The option *Audio Generator and Analyzer CMU-B41* also includes the Multitone measurement feature.

The option *Speech Codec CMU-B52* contains the ACELP codec type.

