

Service Manual Instrument



Universal Radio Communication Tester

R&S® CMU 200

1100.0008.02/53

R&S® CMU 300

1100.0008.03

Printed in Germany



1100.4903.82-05

Tabbed Divider Overview

Spare Parts Express Service
List of R&S Representatives
Safety Instructions

Contents

Contents of Manuals for Universal Radio Communication Tester R&S CMU

Tabbed Divider

1	Chapter 1: Performance Test
2	Chapter 2: Adjustment
3	Chapter 3: Repair
4	Chapter 4: Software Update / Installation of Options
5	Chapter 5: Documents

Index

Grouped Safety Messages









Make sure to read through and observe the following safety instructions!







All plants and locations of the Rohde & Schwarz group of companies make every effort to keep the safety standard of our products up to date and to offer our customers the highest possible degree of safety. Our products and the auxiliary equipment required for them are designed and tested in accordance with the relevant safety standards. Compliance with these standards is continuously monitored by our quality assurance system. The product described here has been designed and tested in accordance with the EC Certificate of Conformity and has left the manufacturer's plant in a condition fully complying with safety standards. To maintain this condition and to ensure safe operation, observe all instructions and warnings provided in this manual. If you have any questions regarding these safety instructions, the Rohde & Schwarz group of companies will be happy to answer them.

Furthermore, it is your responsibility to use the product in an appropriate manner. This product is designed for use solely in industrial and laboratory environments or, if expressly permitted, also in the field and must not be used in any way that may cause personal injury or property damage. You are responsible if the product is used for an intention other than its designated purpose or in disregard of the manufacturer's instructions. The manufacturer shall assume no responsibility for such use of the product.

The product is used for its designated purpose if it is used in accordance with its product documentation and within its performance limits (see data sheet, documentation, the following safety instructions). Using the product requires technical skills and a basic knowledge of English. It is therefore essential that only skilled and specialized staff or thoroughly trained personnel with the required skills be allowed to use the product. If personal safety gear is required for using Rohde & Schwarz products, this will be indicated at the appropriate place in the product documentation. Keep the basic safety instructions and the product documentation in a safe place and pass them on to the subsequent users.

Symbols and safety labels

							
Observe product documentation	Weight indication for units >18 kg	Danger of electric shock	Warning! Hot surface	PE terminal	Ground	Ground terminal	Attention! Electrostatic sensitive devices

					
Supply voltage ON/OFF	Standby indication	Direct current (DC)	Alternating current (AC)	Direct/alternating current (DC/AC)	Device fully protected by double/reinforced insulation

Observing the safety instructions will help prevent personal injury or damage of any kind caused by dangerous situations. Therefore, carefully read through and adhere to the following safety instructions before putting the product into operation. It is also absolutely essential to observe the additional safety instructions on personal safety that appear in relevant parts of the product documentation. In these safety instructions, the word "product" refers to all merchandise sold and distributed by the Rohde & Schwarz group of companies, including instruments, systems and all accessories.

Tags and their meaning

DANGER	DANGER indicates a hazardous situation which, if not avoided, will result in death or serious injury.
WARNING	WARNING indicates a hazardous situation which, if not avoided, could result in death or serious injury.
CAUTION	CAUTION indicates a hazardous situation which, if not avoided, may result in minor or moderate injury.
NOTICE	NOTICE indicates a property damage message.

In the product documentation, the word ATTENTION is used synonymously.

These tags are in accordance with the standard definition for civil applications in the European Economic Area. Definitions that deviate from the standard definition may also exist in other economic areas or military applications. It is therefore essential to make sure that the tags described here are always used only in connection with the related product documentation and the related product. The use of tags in connection with unrelated products or documentation can result in misinterpretation and thus contribute to personal injury or material damage.

Basic safety instructions

1. The product may be operated only under the operating conditions and in the positions specified by the manufacturer. Its ventilation must not be obstructed during operation. Unless otherwise specified, the following requirements apply to Rohde & Schwarz products:
prescribed operating position is always with the housing floor facing down, IP protection 2X, pollution severity 2, overvoltage category 2, use only in enclosed spaces, max. operation altitude 2000 m above sea level, max. transport altitude 4500 m above sea level.
A tolerance of $\pm 10\%$ shall apply to the nominal voltage and of $\pm 5\%$ to the nominal frequency.
2. Applicable local or national safety regulations and rules for the prevention of accidents must be observed in all work performed. The product may be opened only by authorized, specially trained personnel. Prior to performing any work on the product or opening the product, the product must be disconnected from the supply network. Any adjustments, replacements of parts, maintenance or repair must be carried out only by technical personnel authorized by Rohde & Schwarz. Only original parts may be used for replacing parts relevant to safety (e.g. power switches, power transformers, fuses). A safety test must always be performed after parts relevant to safety have been replaced (visual inspection, PE conductor test, insulation resistance measurement, leakage current measurement, functional test).
3. As with all industrially manufactured goods, the use of substances that induce an allergic reaction (allergens, e.g. nickel) such as aluminum cannot be generally excluded. If you develop an allergic reaction (such as a skin rash, frequent sneezing, red eyes or respiratory difficulties), consult a physician immediately to determine the cause.
4. If products/components are mechanically and/or thermally processed in a manner that goes beyond their intended use, hazardous substances (heavy-metal dust such as lead, beryllium, nickel) may be released. For this reason, the product may only be disassembled, e.g. for disposal purposes, by specially trained personnel. Improper disassembly may be hazardous to your health. National waste disposal regulations must be observed.

Grouped Safety Messages

5. If handling the product yields hazardous substances or fuels that must be disposed of in a special way, e.g. coolants or engine oils that must be replenished regularly, the safety instructions of the manufacturer of the hazardous substances or fuels and the applicable regional waste disposal regulations must be observed. Also observe the relevant safety instructions in the product documentation.
6. Depending on the function, certain products such as RF radio equipment can produce an elevated level of electromagnetic radiation. Considering that unborn life requires increased protection, pregnant women should be protected by appropriate measures. Persons with pacemakers may also be endangered by electromagnetic radiation. The employer/operator is required to assess workplaces where there is a special risk of exposure to radiation and, if necessary, take measures to avert the danger.
7. Operating the products requires special training and intense concentration. Make certain that persons who use the products are physically, mentally and emotionally fit enough to handle operating the products; otherwise injuries or material damage may occur. It is the responsibility of the employer to select suitable personnel for operating the products.
8. Prior to switching on the product, it must be ensured that the nominal voltage setting on the product matches the nominal voltage of the AC supply network. If a different voltage is to be set, the power fuse of the product may have to be changed accordingly.
9. In the case of products of safety class I with movable power cord and connector, operation is permitted only on sockets with earthing contact and protective earth connection.
10. Intentionally breaking the protective earth connection either in the feed line or in the product itself is not permitted. Doing so can result in the danger of an electric shock from the product. If extension cords or connector strips are implemented, they must be checked on a regular basis to ensure that they are safe to use.
11. If the product has no power switch for disconnection from the AC supply, the plug of the connecting cable is regarded as the disconnecting device. In such cases, it must be ensured that the power plug is easily reachable and accessible at all times (corresponding to the length of connecting cable, approx. 2 m). Functional or electronic switches are not suitable for providing disconnection from the AC supply. If products without power switches are integrated in racks or systems, a disconnecting device must be provided at the system level.
12. Never use the product if the power cable is damaged. Check the power cable on a regular basis to ensure that it is in proper operating condition. By taking appropriate safety measures and carefully laying the power cable, ensure that the cable cannot be damaged and that no one can be hurt by e.g. tripping over the cable or suffering an electric shock.
13. The product may be operated only from TN/TT supply networks fused with max. 16 A (higher fuse only after consulting with the Rohde & Schwarz group of companies).
14. Do not insert the plug into sockets that are dusty or dirty. Insert the plug firmly and all the way into the socket. Otherwise, this can result in sparks, fire and/or injuries.
15. Do not overload any sockets, extension cords or connector strips; doing so can cause fire or electric shocks.
16. For measurements in circuits with voltages $V_{\text{rms}} > 30 \text{ V}$, suitable measures (e.g. appropriate measuring equipment, fusing, current limiting, electrical separation, insulation) should be taken to avoid any hazards.
17. Ensure that the connections with information technology equipment comply with IEC 950/EN 60950.
18. Unless expressly permitted, never remove the cover or any part of the housing while the product is in operation. Doing so will expose circuits and components and can lead to injuries, fire or damage to the product.
19. If a product is to be permanently installed, the connection between the PE terminal on site and the product's PE conductor must be made first before any other connection is made. The product may be installed and connected only by a license electrician.

Grouped Safety Messages

20. For permanently installed equipment without built-in fuses, circuit breakers or similar protective devices, the supply circuit must be fused in such a way that suitable protection is provided for users and products.
21. Do not insert any objects into the openings in the housing that are not designed for this purpose. Never pour any liquids onto or into the housing. This can cause short circuits inside the product and/or electric shocks, fire or injuries.
22. Use suitable overvoltage protection to ensure that no overvoltage (such as that caused by a thunderstorm) can reach the product. Otherwise the operating personnel will be endangered by electric shocks.
23. Rohde & Schwarz products are not protected against penetration of liquids, unless otherwise specified (see also safety instruction 1.). If this is not taken into account, there exists the danger of electric shock for the user or damage to the product, which can also lead to personal injury.
24. Never use the product under conditions in which condensation has formed or can form in or on the product, e.g. if the product was moved from a cold to a warm environment.
25. Do not close any slots or openings on the product, since they are necessary for ventilation and prevent the product from overheating. Do not place the product on soft surfaces such as sofas or rugs or inside a closed housing, unless this is well ventilated.
26. Do not place the product on heat-generating devices such as radiators or fan heaters. The temperature of the environment must not exceed the maximum temperature specified in the data sheet.
27. Batteries and storage batteries must not be exposed to high temperatures or fire. Keep batteries and storage batteries away from children. Do not short-circuit batteries and storage batteries.
If batteries or storage batteries are improperly replaced, this can cause an explosion (warning: lithium cells). Replace the battery or storage battery only with the matching Rohde & Schwarz type (see spare parts list). Batteries and storage batteries must be recycled and kept separate from residual waste. Batteries and storage batteries that contain lead, mercury or cadmium are hazardous waste. Observe the national regulations regarding waste disposal and recycling.
28. Please be aware that in the event of a fire, toxic substances (gases, liquids etc.) that may be hazardous to your health may escape from the product.
29. The product can be very heavy. Be careful when moving it to avoid back or other physical injuries.
30. Do not place the product on surfaces, vehicles, cabinets or tables that for reasons of weight or stability are unsuitable for this purpose. Always follow the manufacturer's installation instructions when installing the product and fastening it to objects or structures (e.g. walls and shelves).
31. Handles on the products are designed exclusively for personnel to hold or carry the product. It is therefore not permissible to use handles for fastening the product to or on means of transport such as cranes, fork lifts, wagons, etc. The user is responsible for securely fastening the products to or on the means of transport and for observing the safety regulations of the manufacturer of the means of transport. Noncompliance can result in personal injury or material damage.
32. If you use the product in a vehicle, it is the sole responsibility of the driver to drive the vehicle safely. Adequately secure the product in the vehicle to prevent injuries or other damage in the event of an accident. Never use the product in a moving vehicle if doing so could distract the driver of the vehicle. The driver is always responsible for the safety of the vehicle. The manufacturer assumes no responsibility for accidents or collisions.
33. If a laser product (e.g. a CD/DVD drive) is integrated in a Rohde & Schwarz product, do not use any other settings or functions than those described in the product documentation. Otherwise this may be hazardous to your health, since the laser beam can cause irreversible damage to your eyes. Never try to take such products apart, and never look into the laser beam.
34. Prior to cleaning, disconnect the product from the AC supply. Use a soft, non-linting cloth to clean the product. Never use chemical cleaning agents such as alcohol, acetone or diluent for cellulose lacquers.

Informaciones elementales de seguridad

¡Es imprescindible leer y observar las siguientes instrucciones e informaciones de seguridad!







El principio del grupo de empresas Rohde & Schwarz consiste en tener nuestros productos siempre al día con los estándares de seguridad y de ofrecer a nuestros clientes el máximo grado de seguridad. Nuestros productos y todos los equipos adicionales son siempre fabricados y examinados según las normas de seguridad vigentes. Nuestra sección de gestión de la seguridad de calidad controla constantemente que sean cumplidas estas normas. El presente producto ha sido fabricado y examinado según el comprobante de conformidad adjunto según las normas de la CE y ha salido de nuestra planta en estado impecable según los estándares técnicos de seguridad. Para poder preservar este estado y garantizar un funcionamiento libre de peligros, el usuario deberá atenerse a todas las indicaciones, informaciones de seguridad y notas de alerta. El grupo de empresas Rohde & Schwarz está siempre a su disposición en caso de que tengan preguntas referentes a estas informaciones de seguridad.

Además queda en la responsabilidad del usuario utilizar el producto en la forma debida. Este producto está destinado exclusivamente al uso en la industria y el laboratorio o, si ha sido expresamente autorizado, para aplicaciones de campo y de ninguna manera deberá ser utilizado de modo que alguna persona/cosa pueda sufrir daño. El uso del producto fuera de sus fines definidos o despreciando las informaciones de seguridad del fabricante queda en la responsabilidad del usuario. El fabricante no se hace en ninguna forma responsable de consecuencias a causa del mal uso del producto.

Se parte del uso correcto del producto para los fines definidos si el producto es utilizado dentro de las instrucciones de la correspondiente documentación de producto y dentro del margen de rendimiento definido (ver hoja de datos, documentación, informaciones de seguridad que siguen). El uso del producto hace necesarios conocimientos profundos y conocimientos básicas del idioma inglés. Por eso se debe tener en cuenta que el producto sólo pueda ser operado por personal especializado o personas minuciosamente instruidas con las capacidades correspondientes. Si fuera necesaria indumentaria de seguridad para el uso de productos de R&S, encontrará la información debida en la documentación del producto en el capítulo correspondiente. Guarde bien las informaciones de seguridad elementales, así como la documentación del producto y entréguela a usuarios posteriores.

Símbolos y definiciones de seguridad

							
Ver documentación de producto	Informaciones para maquinaria con un peso de > 18kg	Peligro de golpe de corriente	¡Advertencia! Superficie caliente	Conexión a conductor protector	Conexión a tierra	Conexión a masa conductora	¡Cuidado! Elementos de construcción con peligro de carga electrostática

					
Potencia EN MARCHA/PARADA	Indicación Stand-by	Corriente continua DC	Corriente alterna AC	Corriente continua/- alterna DC/AC	El aparato está protegido en su totalidad por un aislamiento de doble refuerzo

Informaciones elementales de seguridad

Tener en cuenta las informaciones de seguridad sirve para tratar de evitar daños y peligros de toda clase. Es necesario de que se lean las siguientes informaciones de seguridad concienzudamente y se tengan en cuenta debidamente antes de la puesta en funcionamiento del producto. También deberán ser tenidas en cuenta las informaciones para la protección de personas que encontrarán en el capítulo correspondiente de la documentación de producto y que también son obligatorias de seguir. En las informaciones de seguridad actuales hemos juntado todos los objetos vendidos por el grupo de empresas Rohde & Schwarz bajo la denominación de „producto“, entre ellos también aparatos, instalaciones así como toda clase de accesorios.

Palabras de señal y su significado

PELIGRO	Identifica un peligro directo con riesgo elevado de provocar muerte o lesiones de gravedad si no se toman las medidas oportunas.
ADVERTENCIA	Identifica un posible peligro con riesgo medio de provocar muerte o lesiones (de gravedad) si no se toman las medidas oportunas.
ATENCIÓN	Identifica un peligro con riesgo reducido de provocar lesiones de gravedad media o leve si no se toman las medidas oportunas.
AVISO	Indica la posibilidad de utilizar mal el producto y a consecuencia dañarlo. En la documentación del producto se emplea de forma sinónima el término CUIDADO.

Las palabras de señal corresponden a la definición habitual para aplicaciones civiles en el área económica europea. Pueden existir definiciones diferentes a esta definición en otras áreas económicas o en aplicaciones militares. Por eso se deberá tener en cuenta que las palabras de señal aquí descritas sean utilizadas siempre solamente en combinación con la correspondiente documentación de producto y solamente en combinación con el producto correspondiente. La utilización de las palabras de señal en combinación con productos o documentaciones que no les correspondan puede llevar a malinterpretaciones y tener por consecuencia daños en personas u objetos.

Informaciones de seguridad elementales

1. El producto solamente debe ser utilizado según lo indicado por el fabricante referente a la situación y posición de funcionamiento sin que se obstruya la ventilación. Si no se convino de otra manera, es para los productos R&S válido lo que sigue:
como posición de funcionamiento se define por principio la posición con el suelo de la caja para abajo, modo de protección IP 2X, grado de suciedad 2, categoría de sobrecarga eléctrica 2, utilizar solamente en estancias interiores, utilización hasta 2000 m sobre el nivel del mar, transporte hasta 4.500 m sobre el nivel del mar.
Se aplicará una tolerancia de $\pm 10\%$ sobre el voltaje nominal y de $\pm 5\%$ sobre la frecuencia nominal.
2. En todos los trabajos deberán ser tenidas en cuenta las normas locales de seguridad de trabajo y de prevención de accidentes. El producto solamente debe de ser abierto por personal especializado autorizado. Antes de efectuar trabajos en el producto o abrirlo deberá este ser desconectado de la corriente. El ajuste, el cambio de partes, la manutención y la reparación deberán ser solamente efectuadas por electricistas autorizados por R&S. Si se reponen partes con importancia para los aspectos de seguridad (por ejemplo el enchufe, los transformadores o los fusibles), solamente podrán ser sustituidos por partes originales. Después de cada recambio de partes elementales para la seguridad deberá ser efectuado un control de seguridad (control a primera vista, control de conductor protector, medición de resistencia de aislamiento, medición de la corriente conductora, control de funcionamiento).

Informaciones elementales de seguridad

3. Como en todo producto de fabricación industrial no puede ser excluido en general de que se produzcan al usarlo elementos que puedan generar alergias, los llamados elementos alergénicos (por ejemplo el níquel). Si se produjeran en el trato con productos R&S reacciones alérgicas, como por ejemplo urticaria, estornudos frecuentes, irritación de la conjuntiva o dificultades al respirar, se deberá consultar inmediatamente a un médico para averiguar los motivos de estas reacciones.
 4. Si productos / elementos de construcción son tratados fuera del funcionamiento definido de forma mecánica o térmica, pueden generarse elementos peligrosos (polvos de sustancia de metales pesados como por ejemplo plomo, berilio, níquel). La partición elemental del producto, como por ejemplo sucede en el tratamiento de materias residuales, debe de ser efectuada solamente por personal especializado para estos tratamientos. La partición elemental efectuada inadecuadamente puede generar daños para la salud. Se deben tener en cuenta las directivas nacionales referentes al tratamiento de materias residuales.
 5. En el caso de que se produjeran agentes de peligro o combustibles en la aplicación del producto que debieran de ser transferidos a un tratamiento de materias residuales, como por ejemplo agentes refrigerantes que deben ser repuestos en periodos definidos, o aceites para motores, deberán ser tenidas en cuenta las prescripciones de seguridad del fabricante de estos agentes de peligro o combustibles y las regulaciones regionales para el tratamiento de materias residuales. Cuiden también de tener en cuenta en caso dado las prescripciones de seguridad especiales en la descripción del producto.
 6. Ciertos productos, como por ejemplo las instalaciones de radiocomunicación RF, pueden a causa de su función natural, emitir una radiación electromagnética aumentada. En vista a la protección de la vida en desarrollo deberían ser protegidas personas embarazadas debidamente. También las personas con un bypass pueden correr peligro a causa de la radiación electromagnética.
- El empresario/usuario está comprometido a valorar y señalar áreas de trabajo en las que se corra un riesgo aumentado de exposición a radiaciones para evitar riesgos.
7. La utilización de los productos requiere instrucciones especiales y una alta concentración en el manejo. Debe de ponerse por seguro de que las personas que manejen los productos estén a la altura de los requerimientos necesarios referente a sus aptitudes físicas, psíquicas y emocionales, ya que de otra manera no se pueden excluir lesiones o daños de objetos. El empresario lleva la responsabilidad de seleccionar el personal usuario apto para el manejo de los productos.
 8. Antes de la puesta en marcha del producto se deberá tener por seguro de que la tensión preseleccionada en el producto equivalga a la del la red de distribución. Si es necesario cambiar la preselección de la tensión también se deberán en caso dabo cambiar los fusibles correspondientes del producto.
 9. Productos de la clase de seguridad I con alimentación móvil y enchufe individual de producto solamente deberán ser conectados para el funcionamiento a tomas de corriente de contacto de seguridad y con conductor protector conectado.
 10. Queda prohibida toda clase de interrupción intencionada del conductor protector, tanto en la toma de corriente como en el mismo producto. Puede tener como consecuencia el peligro de golpe de corriente por el producto. Si se utilizaran cables o enchufes de extensión se deberá poner al seguro que es controlado su estado técnico de seguridad.
 11. Si el producto no está equipado con un interruptor para desconectarlo de la red, se deberá considerar el enchufe del cable de distribución como interruptor. En estos casos deberá asegurar de que el enchufe sea de fácil acceso y nabejo (según la medida del cable de distribución, aproximadamente 2 m). Los interruptores de función o electrónicos no son aptos para el corte de la red eléctrica. Si los productos sin interruptor están integrados en bastidores o instalaciones, se deberá instalar el interruptor al nivel de la instalación.

Informaciones elementales de seguridad

12. No utilice nunca el producto si está dañado el cable eléctrico. Compruebe regularmente el correcto estado de los cables de conexión a red. Asegure a través de las medidas de protección y de instalación adecuadas de que el cable de eléctrico no pueda ser dañado o de que nadie pueda ser dañado por él, por ejemplo al tropezar o por un golpe de corriente.
13. Solamente está permitido el funcionamiento en redes de distribución TN/TT aseguradas con fusibles de como máximo 16 A (utilización de fusibles de mayor amperaje sólo previa consulta con el grupo de empresas Rohde & Schwarz).
14. Nunca conecte el enchufe en tomas de corriente sucias o llenas de polvo. Introduzca el enchufe por completo y fuertemente en la toma de corriente. Si no tiene en consideración estas indicaciones se arriesga a que se originen chispas, fuego y/o heridas.
15. No sobrecargue las tomas de corriente, los cables de extensión o los enchufes de extensión ya que esto pudiera causar fuego o golpes de corriente.
16. En las mediciones en circuitos de corriente con una tensión de entrada de $U_{\text{eff}} > 30 \text{ V}$ se deberá tomar las precauciones debidas para impedir cualquier peligro (por ejemplo medios de medición adecuados, seguros, limitación de tensión, corte protector, aislamiento etc.).
17. En caso de conexión con aparatos de la técnica informática se deberá tener en cuenta que estos cumplan los requisitos del estándar IEC950/EN60950.
18. A menos que esté permitido expresamente, no retire nunca la tapa ni componentes de la carcasa mientras el producto esté en servicio. Esto pone a descubierto los cables y componentes eléctricos y puede causar heridas, fuego o daños en el producto.
19. Si un producto es instalado fijamente en un lugar, se deberá primero conectar el conductor protector fijo con el conductor protector del aparato antes de hacer cualquier otra conexión. La instalación y la conexión deberán ser efectuadas por un electricista especializado.
20. En caso de que los productos que son instalados fijamente en un lugar sean sin protector implementado, autointerruptor o similares objetos de protección, el circuito de suministro de corriente deberá estar protegido de manera que usuarios y productos estén suficientemente protegidos.
21. Por favor, no introduzca ningún objeto que no esté destinado a ello en los orificios de la caja del aparato. No vierta nunca ninguna clase de líquidos sobre o en la caja. Esto puede producir cortocircuitos en el producto y/o puede causar golpes de corriente, fuego o heridas.
22. Asegúrese con la protección adecuada de que no pueda originarse en el producto una sobrecarga por ejemplo a causa de una tormenta. Si no se verá el personal que lo utilice expuesto al peligro de un golpe de corriente.
23. Los productos R&S no están protegidos contra líquidos si no es que exista otra indicación, ver también punto 1. Si no se tiene en cuenta esto se arriesga el peligro de golpe de corriente para el usuario o de daños en el producto lo cual también puede llevar al peligro de personas.
24. No utilice el producto bajo condiciones en las que pueda producirse y se hayan producido líquidos de condensación en o dentro del producto como por ejemplo cuando se desplaza el producto de un lugar frío a un lugar caliente.
25. Por favor no cierre ninguna ranura u orificio del producto, ya que estas son necesarias para la ventilación e impiden que el producto se caliente demasiado. No pongan el producto encima de materiales blandos como por ejemplo sofás o alfombras o dentro de una caja cerrada, si esta no está suficientemente ventilada.
26. No ponga el producto sobre aparatos que produzcan calor, como por ejemplo radiadores o calentadores. La temperatura ambiental no debe superar la temperatura máxima especificada en la hoja de datos.

Informaciones elementales de seguridad

27. Baterías y acumuladores no deben de ser expuestos a temperaturas altas o al fuego. Guardar baterías y acumuladores fuera del alcance de los niños. No cortocircuitar baterías ni acumuladores. Si las baterías o los acumuladores no son cambiados con la debida atención existirá peligro de explosión (atención células de litio). Cambiar las baterías o los acumuladores solamente por los del tipo R&S correspondiente (ver lista de piezas de recambio). Las baterías y acumuladores deben reutilizarse y no deben acceder a los vertederos. Las baterías y acumuladores que contienen plomo, mercurio o cadmio deben tratarse como residuos especiales. Respete en esta relación las normas nacionales de evacuación y reciclaje.
28. Por favor tengan en cuenta que en caso de un incendio pueden desprenderse del producto agentes venenosos (gases, líquidos etc.) que pueden generar daños a la salud.
29. El producto puede poseer un peso elevado. Muévelo con cuidado para evitar lesiones en la espalda u otras partes corporales.
30. No sitúe el producto encima de superficies, vehículos, estantes o mesas, que por sus características de peso o de estabilidad no sean aptas para él. Siga siempre las instrucciones de instalación del fabricante cuando instale y asegure el producto en objetos o estructuras (por ejemplo paredes y estantes).
31. Las asas instaladas en los productos sirven solamente de ayuda para el manejo que solamente está previsto para personas. Por eso no está permitido utilizar las asas para la sujeción en o sobre medios de transporte como por ejemplo grúas, carretillas elevadoras de horquilla, carros etc. El usuario es responsable de que los productos sean sujetados de forma segura a los medios de transporte y de que las prescripciones de seguridad del fabricante de los medios de transporte sean observadas. En caso de que no se tengan en cuenta pueden causarse daños en personas y objetos.
32. Si llega a utilizar el producto dentro de un vehículo, queda en la responsabilidad absoluta del conductor que conducir el vehículo de manera segura. Asegure el producto dentro del vehículo debidamente para evitar en caso de un accidente las lesiones u otra clase de daños. No utilice nunca el producto dentro de un vehículo en movimiento si esto pudiera distraer al conductor. Siempre queda en la responsabilidad absoluta del conductor la seguridad del vehículo. El fabricante no asumirá ninguna clase de responsabilidad por accidentes o colisiones.
33. Dado el caso de que esté integrado un producto de láser en un producto R&S (por ejemplo CD/DVD-ROM) no utilice otras instalaciones o funciones que las descritas en la documentación de producto. De otra manera pondrá en peligro su salud, ya que el rayo láser puede dañar irreversiblemente sus ojos. Nunca trate de descomponer estos productos. Nunca mire dentro del rayo láser.
34. Antes de proceder a la limpieza, desconecte el producto de la red. Realice la limpieza con un paño suave, que no se deshilache. No utilice de ninguna manera agentes limpiadores químicos como, por ejemplo, alcohol, acetona o nitrodiluyente.

Safety Instructions for Units with Removable Cabinet

⚠ WARNING

Danger of injuries

When removing the rear feet, the unit can slip out of the cabinet.

Put the unit onto the front handles, before removing the rear feet and taking off the cabinet. Thus the risk of personal injuries and damages to the unit is avoided.

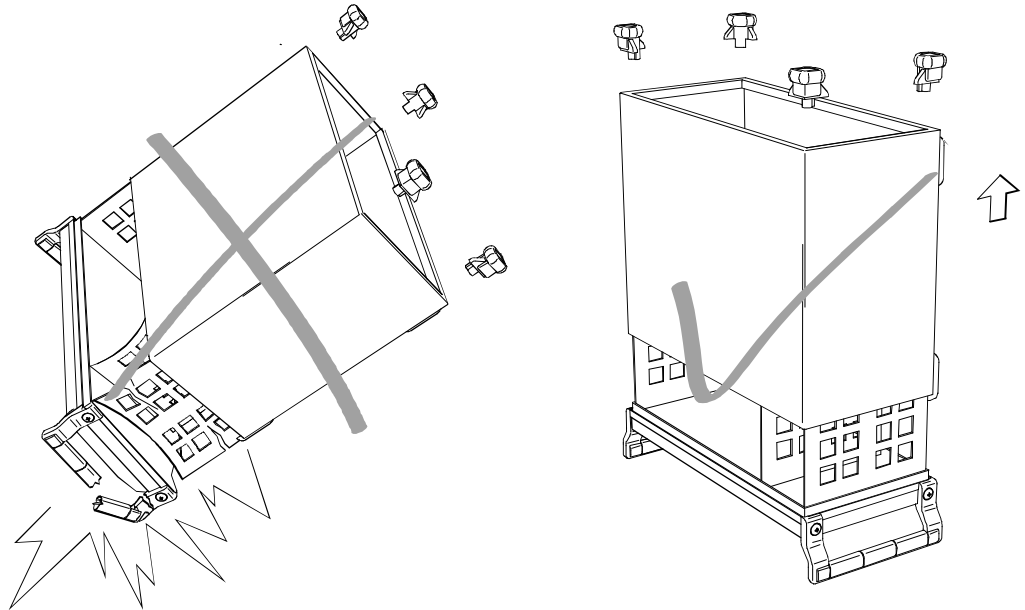

When mounting the cabinet take care not to pin in the fingers. Also pay attention not to damage or pull off cables. Screw the rear feet back on immediately after mounting the cabinet. Do not move the unit with the rear feet missing.

Informaciones de seguridad para aparatos con tubo de quita y pon

⚠ ADVERTENCIA

Peligro de heridas

Al sacar los piés de la pared posterior puede deslizarse el aparato fuera de la caja.

Posicionar el aparato de manera segura sobre las asas delanteras, antes de sacar los piés de la pared posterior y entonces sacar la caja. De esta manera evitarán el riesgo de daños en personas y daños en el aparato.

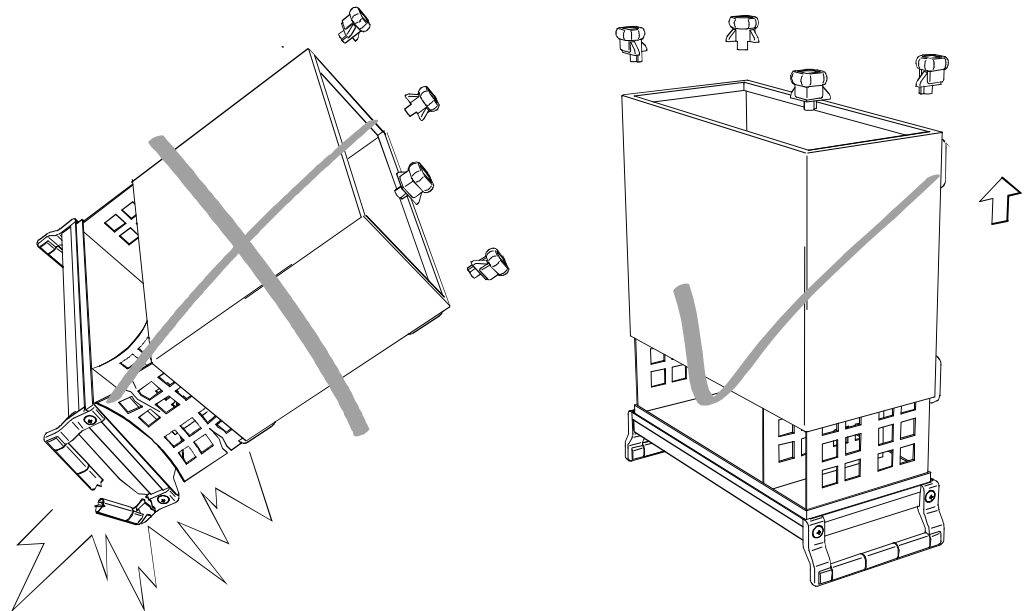

Existe el riesgo de heridas en el momento de poner otra vez la caja, como por ejemplo posiblemente engancharse los dedos. Por favor tengan además en cuenta de que no se enganchen o desconecten cables. Por favor atornillen los piés de la pared posterior directamente despues de poner la caja. No muevan el aparato nunca sin que los piés de la pared posterior estén atornillados.

Instructions for Electrostatic Discharge Protection

NOTICE

Risk of damaging electronic components

To avoid damage of electronic components, the operational site must be protected against electrostatic discharge (ESD).

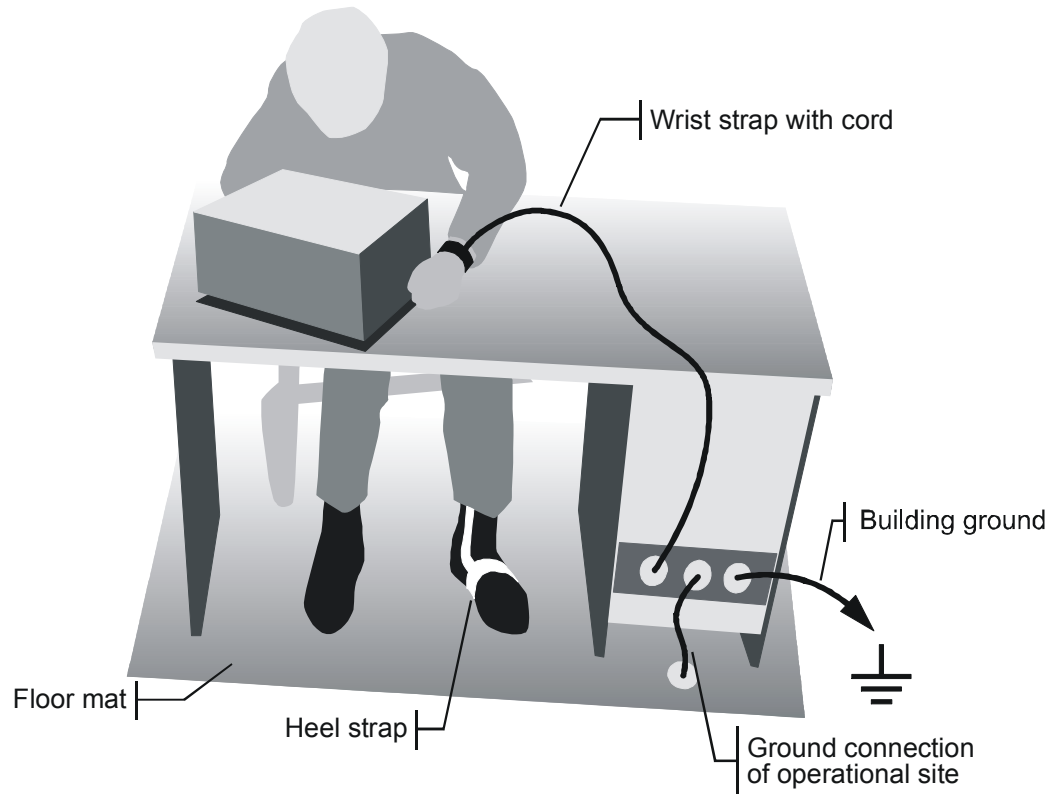

The following two methods of ESD protection may be used together or separately:

- Wrist strap with cord to ground connection
 - Conductive floor mat and heel strap combination
-

Instrucciones para la protección contra descargas electrostáticas

AVISO

Riesgo de avería de los componentes electrónicos

Para evitar averías en los componentes electrónicos, el área de trabajo tiene que estar protegido contra descargas electrostáticas ESD (electrostatic discharge).

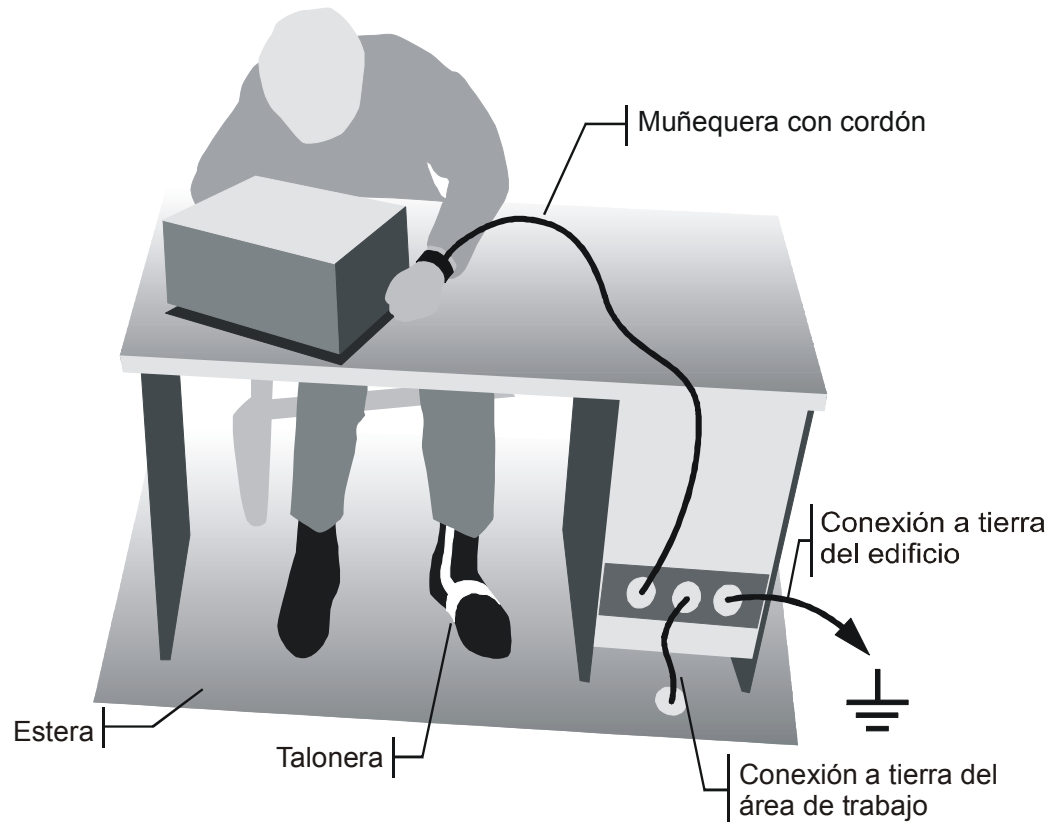

Los siguientes dos métodos de protección ESD pueden ser usados juntos o separados:

- Muñequera con cordón para conexión a tierra
- Combinación de estera antiestática y talonera

Procedure in Case of Service and Ordering of Spare Parts

This section contains information on shipping an instrument to your service center and ordering spare parts.

Please contact your local Rohde & Schwarz service center if you need service or repair work of your equipment or to order spare parts. The list of the Rohde & Schwarz representatives is provided at the beginning of this service manual. You can find the current address of your representative on our homepage www.rohde-schwarz.com. Navigate to Service & Support / Service Locations.

Shipping the Instrument

We require the following information in order to answer your inquiry fast and correctly and to determine whether the warranty is still valid for your instrument:

- Instrument model
- Serial number
- Firmware version
- Must the instrument be returned with this firmware?
- Detailed error description in case of repair
- Indication of desired calibration
- Contact person for possible questions

In some countries, an RMA process is available for the return shipment of the instrument. For details, contact your local representative.

When shipping the instrument, be careful to provide for sufficient mechanical and antistatic protection.

- Use the original packaging for transporting or shipping the instrument. The protective caps for the front and rear prevent damage to the operating elements and the connectors.
- If you do not use the original packaging, provide for sufficient padding to prevent the instrument from slipping inside the box. Wrap antistatic packing foil around the instrument to protect it from electrostatic charging.

Rohde & Schwarz offers repair and calibrations of the test systems it produces. The calibration documentation fulfills ISO 17025 requirements.

Shipping Defective Modules

Also when shipping a module, be careful to provide for sufficient mechanical and antistatic protection.

- Ship the module in a sturdy, padded box.
- Wrap the module in antistatic foil.

If the packaging is only antistatic but not conductive, additional conductive packaging is required. The additional packaging is not required if the tightly fitting packaging is conductive.

Exception:

If the module contains a battery, the tightly fitting packaging must always consist of antistatic, non-chargeable material to protect the battery from being discharged.

Ordering Spare Parts

To deliver spare parts promptly and correctly, we need the following information:

- Stock number (see list of spare parts in chapter "Documents")
- Designation
- Component number according to list of spare parts
- Number of pieces
- Instrument type for which the spare part is needed
- Instrument stock number
- Instrument serial number
- Contact person for possible questions

Refurbished Modules

Refurbished modules are an economical alternative to original modules. Bear in mind that refurbished modules are not new, but repaired and fully tested parts. They may have traces from use, but they are electrically and mechanically equivalent to new modules.

Your Rohde & Schwarz representative will be happy to inform you about which modules are available as refurbished modules.

Taking Back Defective Replaced Modules

Defective modules of the replacement program which cannot be repaired are taken back within three months following delivery. A repurchasing value is credited.

Excluded are parts which cannot be repaired, e.g. printed boards that are burnt, broken or damaged by attempts to repair them, incomplete modules, and parts with severe mechanical damage.

Please return the defective replacement modules, together with the accompanying document for returned merchandise, which you received with the spare module. We need the following information:

- Stock number, serial number and designation of the removed part
- Detailed error description
- Stock number, serial number and type of instrument from which the module was removed
- Date of removal
- Name of the engineer/technician who replaced the module
- R&S ordering number
- Service reference number (if available)

Contents

1 Performance Test.....	1.1
General	1.1
A) Calibration by an R&S Representative with an ACS Calibration System	1.1
B) Sending the Instrument to the Factory (Memmingen, Germany).....	1.1
Necessary Documents	1.1
Measuring Instruments and Auxiliary Equipment.....	1.2
Test Setups	1.3
Reference Frequencies.....	1.3
TX Level Measurements	1.3
General TX measurements.....	1.4
RX Level measurements.....	1.4
General RX Measurements	1.5
RX Demodulation Measurements	1.5
Tolerance Analysis	1.6
Manual Test Procedure	1.7
Selftest	1.7
Interface Test	1.8
IEC-bus Interface	1.8
RS-232 Interface	1.8
Reference Frequencies.....	1.8
REF IN	1.8
REF OUT 1	1.9
REF OUT 2	1.9
TX Frequency Accuracy.....	1.10
TX Frequency Settling Time.....	1.10
TX Level Error	1.10
VSWR	1.10
TX Level Settling Time	1.11
TX Harmonics	1.11
TX Non Harmonics.....	1.11
TX In-Band Spurious Signals	1.11
TX Fixed Spurious Signals.....	1.12
TX SSB Phase Noise	1.12
TX Residual FM.....	1.12
TX Residual AM	1.12
TX Carrier/Sideband Suppression, Max. Distortion	1.13
RX Power Meter (Frequency-Selective).....	1.13

RX Power Meter (Wideband)	1.13
RX Harmonics	1.13
RX Spurious Response / Image Rejection.....	1.14
RX SSB Phase Noise.....	1.14
RX Residual FM/AM.....	1.15
RX Dynamic/ Average Noise Level	1.15
Options for R&S CMU200	1.16
TX GSM Modulation.....	1.16
RX GSM Demodulation.....	1.16
Function Test with Mobile Stations (R&S CMU200).....	1.17
GSM mobile test	1.17
CDMA mobile test	1.17
IS136-mobile test	1.17
AMPS-mobile test	1.17
Test Report.....	1.18
2 Adjustment.....	2.1
Manual Adjustment	2.1
Measuring Instruments and Auxiliary Equipment.....	2.1
Preparing the Instrument.....	2.2
Adjusting the + 5 VDC Reference Voltage	2.2
Adjusting the 10 MHz Reference Frequency.....	2.3
TCXO 2.3	
OCXO REFERENCE OSC. R&S CMU-B11	2.3
OCXO REFERENCE OSC. R&S CMU-B12	2.3
Automatic Adjustment of Module Data	2.4
Preparing the adjustment	2.4
Performing the adjustment	2.4
3 Repair	3.1
Instrument Design and Function Description	3.1
Block diagram	3.2
Instrument Frame.....	3.3
Rear of Instrument Frame.....	3.3
Front of Instrument Frame	3.3
Cooling the Instrument	3.4
FRONT MODULE	3.5
POWER SUPPLY	3.6
MOTHERBOARD.....	3.7
REFERENCE BOARD	3.8

Option OCXO REFERENCE OSC. R&S CMU-B11 or B12	3.9
RF FRONTEND	3.9
RXTX BOARD1	3.10
DIGITAL BOARD.....	3.12
Option UNIVERSAL SIGNALLING UNIT R&S CMU-B21	3.13
Option AUDIO-GEN. + ANA. R&S CMU-B41	3.15
Option CDMA (IS95) Signalling Unit R&S CMU-B81	3.16
MODULE Replacement.....	3.17
Replacing the FRONT MODULE	3.17
Opening the instrument and removing the FRONT MODULE	3.17
Installing the new FRONT MODULE and completing the instrument	3.18
Putting into operation	3.18
Replacing the FRONT MODULE CONTROLLER in the FRONT MODULE	3.19
Opening the instrument and removing the FRONT MODULE	3.19
Removing the FRONT MODULE CONTROLLER from the FRONT MODULE	3.20
Installing the new FRONT MODULE CONTROLLER.....	3.20
Installing the option again and completing the instruments	3.20
Putting into operation	3.21
Replacing the Lithium Battery in the FRONT MODULE.....	3.22
Opening the instrument and removing the FRONT MODULE	3.22
Removing the lithium battery.....	3.23
Installing the new battery and completing the instrument	3.24
Putting into operation	3.24
Replacing the Hard Disk in the FRONT MODULE.....	3.25
Opening the instrument and removing the FRONT MODULE	3.25
Removing the hard disk from the FRONT MODULE	3.26
Installing the new hard disk	3.26
Putting into operation	3.27
Replacing the Memory Modules in the FRONT MODULE	3.28
Opening the instrument and removing the FRONT MODULE	3.28
Making the memory modules accessible	3.29
Removing the memory module	3.29
Installing the new memory module and completing the instrument	3.29
Putting into operation	3.29
Replacing the LCD and/or DC/AC Converter in the FRONT MODULE	3.30
Opening the instrument and removing the FRONT MODULE	3.30
Making the LCD accessible.....	3.31
Removing the LCD and/or DC/AC Converter.....	3.31
Installing the new LCD and/or DC/AC converter and completing the instrument	3.31
Putting into operation	3.31
Replacing the Keyboard Membrane and/or Mat on the FRONT MODULE.....	3.32
Opening the instrument and removing the FRONT MODULE	3.32
Removing the membrane.....	3.33
Installing the new membrane and completing the instrument.....	3.33
Putting into operation	3.33
Replacing the Labeling Panel on the FRONT MODULE.....	3.34
Removing the old labeling panel	3.34
Installing the new labeling panel and completing the instrument.....	3.34

Putting into operation	3.34
Replacing the Options FLOPPY DISK DRIVE R&S CMU-B61 or PCMCIA INTERFACE.....	3.35
Opening the instrument and removing the FRONT MODULE	3.35
Replacing the option.....	3.36
Completing the instrument and putting into operation.....	3.36
Replacing the RF FRONTEND	3.37
Opening the instrument and removing the RF FRONTEND	3.37
Installing the new RF FRONTEND MODULE and completing the instrument.....	3.37
Automatic module data adjustment.....	3.37
Replacing the REFERENCE BOARD	3.38
Opening the instrument and removing the REFERENCE BOARD	3.38
Installing the new REFERENCE BOARD and completing the instrument	3.38
Automatic module data adjustment.....	3.38
Replacing the RXTX BOARD1	3.39
Opening the instrument and removing the RXTX BOARD1	3.39
Installing the new RXTX BOARD1 and completing the instrument.....	3.39
Automatic module data adjustment.....	3.39
Replacing the TR-CORRECTION MODULE in the RXTX BOARD1	3.40
Opening the instrument and removing the TR-CORRECTION MODULE	3.40
Installing the new TR-CORRECTION BOARD and completing the instr.	3.40
Automatic module data adjustment.....	3.40
Replacing the DIGITAL BOARD.....	3.41
Opening the instrument and removing the DIGITAL BOARD	3.41
Installing the new DIGITAL BOARD and completing the instrument	3.41
Automatic module data adjustment.....	3.41
Replacing the MODULES: ADC MODULE1, DDC MODULE1, TXDSP MODULE1, AUC MODULE1 in the DIGITAL BOARD	3.42
Opening the instrument and removing the modules	3.42
Installing the new sandwich module and completing the instrument	3.42
Automatic module data adjustment.....	3.43
Replacing the Option OCXO REFERENCE OSC. R&S CMU-B11 or R&S CMU-B12	3.44
Opening the instrument and removing the OPTION OCXO REF. OSC.	3.44
Installing the new OPTION OCXO REFERENCE OSC. and completing the instrument	3.44
Manual OCXO adjustment.....	3.44
Replacing the Option UNIVERSAL SIGNALLING UNIT R&S CMU-B21	3.45
Opening the instrument and removing the OPTION UNIV. SIGN. UNIT	3.45
Installing the new OPTION UNIV. SIGN. UNIT and completing the instr.	3.45
Automatic module data adjustment.....	3.45
Replacing the MODULES: DSP MODULE0/1, IQOUT MODULE, OPTION SPEECH CODEC R&S CMU-B52 (INCLUDES DSP MODULE3) in the UNIV. SIGN. UNIT	3.46
Opening the instrument and removing the modules	3.46
Installing the new sandwich module and completing the instrument	3.46
Automatic module data adjustment.....	3.47
Replacing the Option AUDIO-GEN. + ANA. R&S CMU-B41.....	3.48
Opening the instrument and removing the Option AUDIO-GEN. + ANA.	3.48
Installing the new Option AUDIO-GEN. + ANA. and completing the instr.	3.48
Automatic module data adjustment.....	3.48
Replacing the POWER SUPPLY	3.49
Removing the POWER SUPPLY	3.49
Installing the new POWER SUPPLY.....	3.49
Replacing the Instrument Fan	3.50

Opening the instrument and removing the fan	3.50
Installing the new fan and completing the instrument	3.50
Replacing the MOTHERBOARD	3.51
MOTHERBOARD1 (big MOTHERBOARD)	3.51
Opening the instrument and removing MOTHERBOARD1	3.51
Installing the new MOTHERBOARD1 and completing the instrument.....	3.51
MOTHERBOARD2 (small MOTHERBOARD)	3.52
Opening the instrument and removing MOTHERBOARD2	3.52
Installing the new MOTHERBOARD2 and completing the instrument.....	3.52
FRONTPANEL BOARD (at the front of the instrument frame)	3.52
Opening the instrument and removing the FRONTPANEL BOARD	3.52
Installing the new FRONTPANEL BOARD and completing the instrument	3.52
REARPANEL BOARD1 (Interface board for Standard Connectors at the Rear of the Instrument Frame)	3.53
Opening the instrument and removing the REARPANEL BOARD1	3.53
Installing the new REARPANEL BOARD1 and completing the instrument.....	3.53
REARPANEL BOARD2 (Interface Board for Further Connectors at the Rear of the Instrument Frame)	3.53
Opening the Instrument and removing the REARPANEL BOARD2	3.53
Installing the new REARPANEL BOARD2 and completing the instrument.....	3.53
Troubleshooting	3.54
Troubleshooting using the LEDs (H1 to H8) on the MOTHERBOARD	3.55
Troubleshooting using the SELFTEST Menu for Modules	3.57
Troubleshooting using the INFO Menu for Modules	3.58
Troubleshooting using the ERROR messages on the LC display.....	3.60
More troubleshooting.....	3.61
General errors on the transmitter side of the R&S CMU	3.61
General errors on the receiver side of the R&S CMU	3.62
4 Software Update/Installing Options.....	4.1
New Installation of the R&S CMU Software	4.1
Software Update via PCMCIA INTERFACE.....	4.1
Software Update via FLOPPY DISK DRIVE	4.1
Performing a Software Update	4.2
Reinstalling the Old Software	4.3
Loading Software as long as there is no VersionManager in the R&S CMU.....	4.3
Installing the Options.....	4.4
5 Documents.....	5.1
Module and Cable Exchange.....	5.1

Tables

Table 1-1 Measuring instruments and auxiliary equipment for manual performance test.....1.2
Table 1-2 Test report1.18

Table 2-1 Measuring instruments and auxiliary equipment for manual adjustment of the R&S CMU ...2.1
Table 5-1 List of power cables available5.2

Index

A

ADC Module1 (DIGITAL Board)	3.13
Adjustment	
+ 5 VDC Reference Voltage	2.2
10 MHz Reference-Frequency	2.3
Automatic of Module Data	2.4
AUC Module1 (DIGITAL Board)	3.14
AUDIO-GEN. + ANA., R&S CMU-B41	3.18
Auxiliary means	1.2

B

Block diagram	3.2
---------------------	-----

C

CDMA (IS95) Signalling Unit	3.21, 3.22, 3.23
Circuit documents (basic unit)	5.3
Cooling the instrument	3.4

D

DDC Module1 (DIGITAL Board)	3.13
DIGITAL Board	3.13
Documents	5.1
Drawing of all CMU spare parts	See annex
DSP Module (UNIV. SIGN. Unit)	3.15, 3.16

F

Fan See cooling the instrument	
FLOPPY DISK DRIVE (Software Update)	4.1
FRONT Module	3.5
FRONTPANEL Board	3.7, 3.8
Function test with Mobile Stations	1.21

H

Hard disk (FRONT Module)	3.5
--------------------------------	-----

I

Instrument design	3.1
Instrument frame	3.3
Interface test	
IEC bus	1.8
RS-232	1.8
IQOUT Module (UNIV. SIGN. Unit)	3.15, 3.19

L

LCD (FRONT Module)	3.5
Loudspeaker	3.3

M

Manual Test Procedure	1.7
Maximum distortion	1.14
Measuring instruments	1.2
Module replacement	
ADC Module1	3.49
AUC Module1	3.49
DDC Module1	3.49
DIGITAL Board	3.48

DSP Module0/1	3.53, 3.55, 3.58, 3.60, 3.62
FLOPPY Disk Drive R&S CMU-B61	3.42
Front Module	3.25
FRONT Module Controller	3.27
FRONTPANEL Board	3.68, 3.71
Hard Disk	3.33
Instrument fan	3.66
IQOUT Module	3.53, 3.55, 3.58, 3.60, 3.62
Keyboard Membrane	3.39
Labeling Panel	3.41
LCD	3.37
Lithium Battery	3.30
Mat	3.39
Memory Modules	3.34
Motherboard	3.67, 3.70
Motherboard1	3.67, 3.70
Motherboard2	3.68, 3.71
Option AUDIO-GEN. + ANA. CMU-B41	3.63
Option OCXO REFERENCE OSC	3.51
Option SPEECH CODEC ... 3.53, 3.55, 3.58, 3.60, 3.62	
PCMCIA Interface R&S CMU-B62	3.42
POWER SUPPLY	3.65
REARPANEL Board1	3.69
REARPANEL Board2	3.69, 3.72
REFERENCE Board	3.45
RF Frontend	3.44
RXTX Board1	3.46
TR-CORRECTION Module	3.47
TXDSP Module1	3.49
UNIVERSAL SIGNALLING Uni	
t	3.52, 3.55, 3.57, 3.59, 3.61
Motherboard	3.7
Motherboard1	3.7, 3.8
Motherboard2	3.7, 3.8

N

Netclock generation	3.9
---------------------------	-----

O

OCXO	
Adjustment	2.3
REFERENCE OSC. R&S CMU-B11 or B12 (Option)	
.....	3.10
Options	
Installing	4.4
List	4.4
Overttemperature protection (POWER SUPPLY)	3.6

P

PCMCIA INTERFACE (Software Update)	4.1
Performance Test	1.1
Power cables	5.2
Power Factor Correction (PFC, POWER SUPPLY)	3.6
POWER SUPPLY	3.6
POWERGOOD signal (POWER SUPPLY)	3.6

R

R&S CMU-B21	3.14, 3.16, 3.19
R&S CMU-B41	3.18
R&S CMU-B81	3.21, 3.22, 3.23
R&S CMU-K21 (Option)	4.4
REARPANEL Board1	3.7

REARPANEL Board2.....	3.8
REFERENCE Board.....	3.9
Reference frequencies	1.9
Repair	3.1
RF Frontend	3.10
RX Dynamic / average noise level.....	1.16
RX GSM Demodulation	1.17, 1.19, 1.20
RX Harmonics	1.15
RX Power meter (Frequency selective)	1.14
RX Power meter (Wideband).....	1.14
RX Residual FM/AM.....	1.16
RX Spurious response / image rejection.....	1.15
RX SSB Phase Noise.....	1.15
RXTX Board1	3.11

S

Selftest	1.7
Software Update	
New installation.....	4.1
Performing	4.2
Reinstalling the Old Software	4.3
Spare parts (order)	5.1
SPEECH CODEC (UNIV. SIGN. UNIT)3.15, 3.17, 3.19, 3.22, 3.24	
Spinwheel (FRONT Module)	3.5
STANDBY circuit (POWER SUPPLY)	3.6
STANDBY/ON signal (POWER SUPPLY).....	3.6

T

TCXO

Adjustment	2.3
Function	3.9
Test report	1.23
Tolerance analysis.....	1.6
Troubleshooting	
General errors	3.79
using the error messages	3.78
using the LEDs.....	3.74
using the SELFTEST Menu for Modules	3.76
TX carrier/sideband suppression	1.14
TX Frequency Accuracy	1.11
TX Frequency settling time	1.11
TX GSM Modulation	1.17, 1.18, 1.20
TX Harmonics.....	1.12
TX Level Error	1.11
TX Level Settling time.....	1.12
TX Nonharmonics.....	1.12
TX Residual AM.....	1.13
TX Residual FM.....	1.13
TX SSB Phase Noise	1.13
TXDSP Module1 (DIGITAL Board)	3.14

U

Universal Signalling Unit.....	3.14, 3.16, 3.19
Update (software).....	4.2

V

VersionManager (loading).....	4.3
VSWR	1.11

1 Performance Test

This chapter provides the necessary information for checking the technical data of the R&S CMU. Please read the general notes on the test procedure on page 1.7 first. Then follows a list of the measuring equipment required for the performance test; a form for the test report is to be found at the end of this chapter.

The adjustment of the instrument for restoring the data integrity and the measuring equipment required for this purpose will be described in chapter 2 of this service manual.

General

The technical data of a R&S CMU can be checked in the following ways:

A) Calibration by an R&S Representative with an ACS Calibration System

Advantages

- Automatic procedure
- Small measurement uncertainties
- Calibration and readjustment
- In most cases, the instrument does not have to leave the country

B) Sending the Instrument to the Factory (Memmingen, Germany)

Advantages

- Automatic procedure at the final test setup
- Minimum measurement uncertainties
- Calibration and readjustment

Necessary Documents

- Operating manual R&S CMU200/R&S CMU300
- Data sheet R&S CMU200

Note: *It is recommended to read the following journal on the subjects "measurement uncertainty" and "tolerance analysis": ETSI Technical Report ETR 028, June 1997*

Measuring Instruments and Auxiliary Equipment

Table 1-1 Measuring instruments and auxiliary equipment for manual performance test

Item	Type of instrument	Required characteristics	Appropriate device	R & S order number	Use
1	Signal generator	100 kHz to 2.7 GHz, Generation of a GSM/CDMA2000/WCDMA signal (dummy burst)	R&S SME03 R&S SMIQ03 with options B42/B60	1038.6002.03 1125.5555.03	RX measurements
2	Spectrum analyzer	100 kHz to 7 GHz, Demodulation of GSM/CDMA2000/WCDMA signals	R&S FSE with R&S FSE-B7 R&S FSIQ-7 with options B4/B5/B7/B11/B12/B70/ K71 R&S FSP-3	1066.3010.20/30 1119.5005.17 1164.4391.03	TX measurements
3	Power meter		R&S NRVD with sensors R&S NRV-Z4 R&S NRV-Z51		RX measurements, TX measurements
4	Power amplifier	100 kHz to 2.7 GHz, Pout = 100 W			RX measurements
5	Harmonics filter	attenuate the harmonics of the power amplifiers to min 30 dBc			RX measurements
6	Directional coupler	50 MHz to 2.7 GHz, up to 100 W			RX measurements
7	Network analyzer or VSWR Bridge	100 kHz to 2.7 GHz	R&S ZVR R&S ZRC	1043.0009.61	Reflection coefficient/ VSWR RF connectors

Test Setups

The quality of the test setup has an effect on the measurement procedures.

Note: Make sure to use only high-quality coax cables and coax connectors as well as calibrated measuring equipment.

Reference Frequencies

Test setup REF1:

REF1

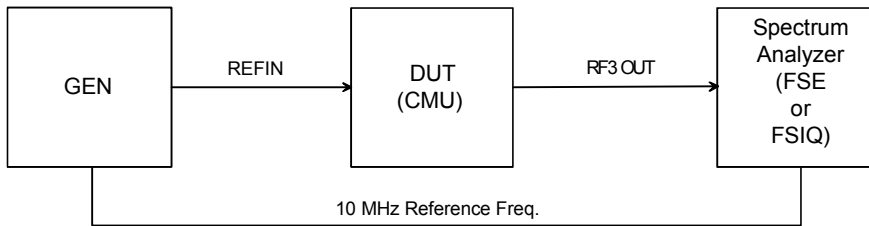

Test setup REF2:

REF2

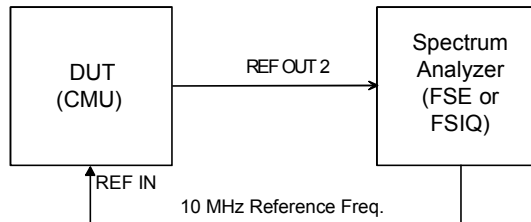

TX Level Measurements

Test setup TX1, TX2, TX3, TX4 (depending on level range):

- Normalize spectrum analyzer (FSIQ) to wideband power meter (NRVD) at *Max. Level* setting of the R&S CMU (test setups TX1, TX2, TX3).

The attenuator of the spectrum analyzer must be held at this position over 60 dB.

- Normalize spectrum analyzer with preamplifier to spectrum analyzer at last level (test setups TX3, TX4).

The attenuator of the spectrum analyzer must be held at this position over 60 dB.

TX1

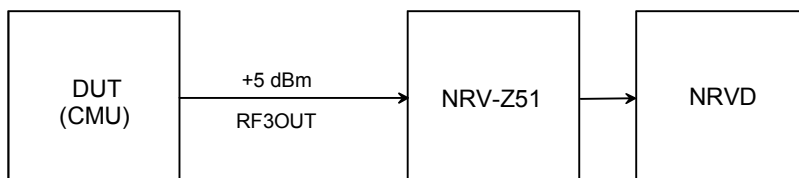

TX2

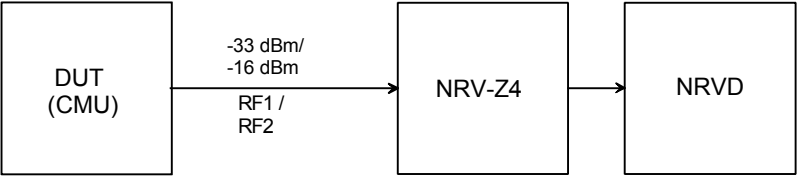

TX3

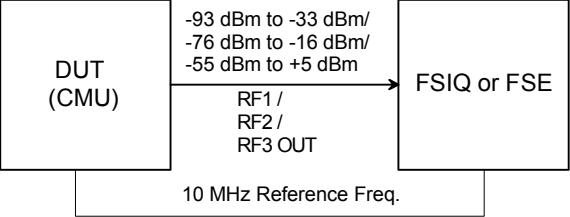

TX4

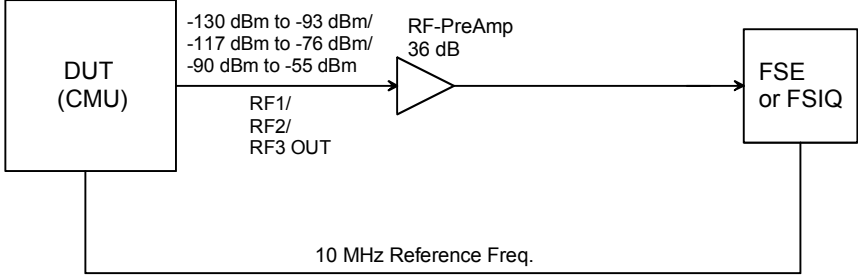

General TX measurements

Test setup TX5:

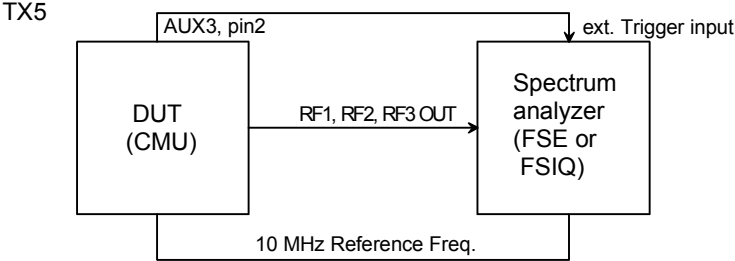

RX Level measurements

Test setup RX1, RX2 (depending on level range):

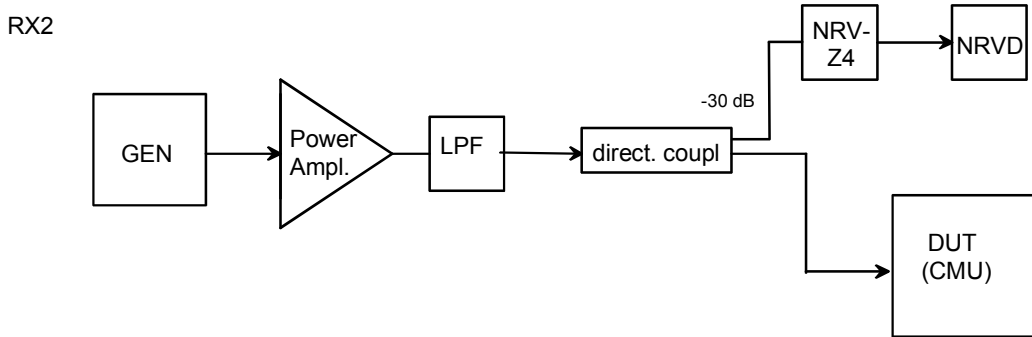
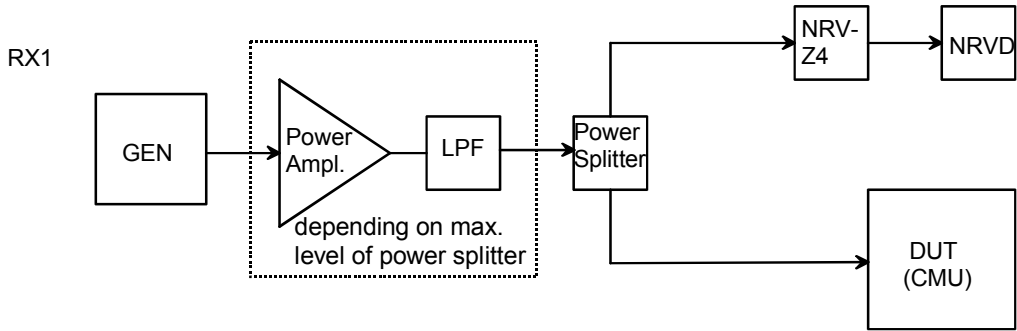

General RX Measurements

Test setup RX3:

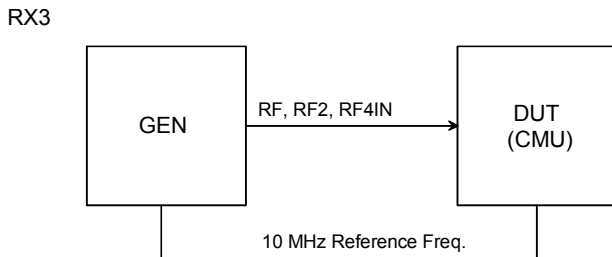

RX Demodulation Measurements

Test setup RX4:

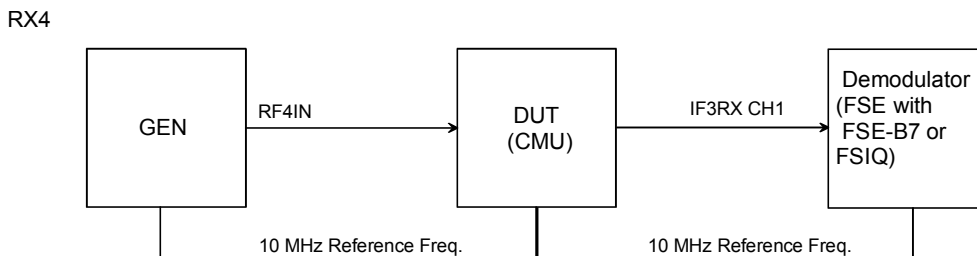

Tolerance Analysis

Due to the small measurement uncertainty of the R&S CMU, the measuring equipment must meet stringent requirements. Since the measurement uncertainty of the measuring equipment to be achieved depends on the test setup used, it is recommended to perform a tolerance analysis.

To be able to trace back errors in the measurement, the measurement uncertainty should also be indicated in the test report.

The tolerances given in the test report refer to the values specified in the data sheet, ie the measurement uncertainties of the test setup used are to be taken into account as well.

Unless otherwise specified, the specified tolerances are always to be observed.

Note: *Please take into account the ETSI Technical Report ETR 028.
The given tolerances refer to R&S CMU data sheet 04/99.*

Manual Test Procedure

Some additional measurements can only be performed using a mobile phone via the normal operating menus of the R&S CMU. These measurements are described in the section '*Function Test with Mobile Stations*'.

The suggested frequencies and levels at which the measurements should be performed have been selected according to the instrument concept. The user can of course also select other frequencies and levels within the scope of values guaranteed in the data sheet.

Note: *Before testing the rated specifications, allow the instrument to warm up for at least 15 min. The ambient temperature should be 23 °C to 26 °C.*

Selftest

The R&S CMU offers various selftest options for checking the functioning and for troubleshooting. Before carrying out the performance test, the *Maintenance* menu in the *BASE* function group should be called up and the following selftests should be performed:

- *Continuous Selftest*
- *1 → 4/3 → 2 RF Loop Test*

Preparation: ➤ Start user SW of the R&S CMU (switch on instrument).

Test: ➤ Select the individual test in the BASE (MAINTENANCE) menu and check the results (*Continuous Selftest, 1 → 4/3 → 2 RF Loop Test*).

Note: *The Continuous Selftest combines the System Selftest and Internal RF Loop Selftest. In this test, only a passed/failed message with error output is indicated. In case of errors, an error file 'cst.err' is created in addition.*

1 → 4/3 → 2 RF Loop Test: Selftest RF Path RF1 → RF4 IN and RF3 OUT → RF2 via external N-coax cable by power measurements via internal generator and analyzer. In this test, all measured values are indicated.

To obtain more detailed information start the following tests:

System selftest:	<i>Selftest of the instrument for diagnostic voltages; only a passed/failed message with error output is indicated.</i>
Internal RF Loop Selftest:	<i>Selftest of the RF path by means of power measurements via internal generator and analyzer. All measured values are indicated.</i>
FE Selftest:	<i>Selftest of the RF FRONTEND module via diagnostic voltages. All measured values are indicated.</i>
REF Selftest:	<i>Selftest of the REFERENCE BOARD module via diagnostic voltages. All measured values are indicated.</i>
DIG Selftest:	<i>Selftest of the DIGITAL BOARD module via diagnostic voltages. All measured values are indicated.</i>
RXTX1 Selftest:	<i>Selftest of the RXTX1 BOARD module via diagnostic voltages. All measured values are indicated.</i>

To obtain more detailed information start the following tests (depending on options and R&S CMU SW versions):

IQIF Selftest:	Selftest of the R&S CMU-B17 IQIF BOARD module via diagnostic voltages. All measured values are indicated.
AUXTX Selftest:	Selftest of the R&S CMU-B95 AUXTX or R&S CMU-B96 AUXTX W BOARD module via diagnostic voltages. All measured values are indicated.
Linkhandler Selftest:	Selftest of the R&S CMU-B21 Var02 ULH and/or R&S CMU-B21 Var14 USU and/or R&S CMU-B66/B68/B76/B78 L1COPRO BOARD module. All measured values are indicated.
IF3 Selftest:	IF3 Level Selftest of the RXTX BOARD module (greater than Board version 11) via diagnostic voltages. All measured values are indicated.
B83 Selftest:	Selftest of the R&S CMU-B83 CDMA LH BOARD module. All measured values are indicated.
RXTX2 Selftest:	Selftest of the RXTX2 BOARD (if available) module via diagnostic voltages. All measured values are indicated.

Interface Test

IEC-bus Interface

- Preparation: ➤ Connect the IEC-bus interfaces of the R&S CMU and the controller via IEC-bus cables.
- Test: ➤ Send the string '*IDN?<CR><NL>' from the controller to the R&S CMU and read the reply *STRING* of the R&S CMU.
- The reply *STRING* must contain the following message:
'ROHDE & SCHWARZ,R&S CMU<Var>,<Ser_Nr>,<Firmware_Vers._Nr>'

RS-232 Interface

- Preparation: ➤ Connect the RS-232 interfaces of the R&S CMU and the controller via null-modem cables
- Set the RS-232 interface of the controller to 8 data bits, 1 start bit, 1 stop bit, no parity bit, XON/XOFF handshake and 19200 baud.
- Test: ➤ Send the string '*IDN?<CR><NL>' from the controller to the R&S CMU and read the reply string of the R&S CMU.
- The reply string must contain the following message:
'ROHDE & SCHWARZ,R&S CMU<Var>,<Ser_Nr>,<Firmware_Vers._No>'

Reference Frequencies

For different range of adjustment of the internal reference oscillator, the synchronization with an external reference frequency is checked.

Note: *The resolution of the frequency counter/analyzer should be max. 1/10 of the maximum permissible deviation.*

REF IN

The frequency and level ranges and the pull-in range are checked. The signal generator and the frequency counter must be synchronized (test setup REF1).

Preparation: ➤ Feed in at REF IN: 52 MHz sinewave, 0.5 V(rms)
 ➤ Connect frequency counter to RF3 OUT.

Control: Set R&S CMU to external reference 52 MHz, RF 1 GHz (menu *RF ANALYZER/GENERATOR.*)

Test: Use frequency counter to measure frequency deviation from 1 GHz.

Preparation: ➤ Feed in at REF IN: 1 MHz sinewave, 0.5 V(rms).
 ➤ Connect frequency counter to RF3 OUT.

Control: ➤ Set R&S CMU to external reference 1 MHz, RF 1 GHz.

Test: ➤ Use frequency counter to measure frequency deviation from 1 GHz.

Preparation: ➤ Feed in at REF IN: 10.000 050 MHz sinewave, 1.4 V(rms).
 ➤ Connect frequency counter to RF3 OUT.

Control: ➤ Set R&S CMU to external reference 10 MHz, RF 1 GHz.

Test: ➤ Use frequency counter to measure frequency deviation from 1.000 005 000 GHz.

Preparation: ➤ Feed in at REF IN: 9.999 950 MHz sinewave, 1.4 V(rms).
 ➤ Connect frequency counter to RF3 OUT.

Control: ➤ Set R&S CMU to external reference 10 MHz, RF 1 GHz.

Test: ➤ Use frequency counter to measure frequency deviation from 0.999 995 GHz.

REF OUT 1

The level and frequency are checked.

- Int. 10 MHz:**
- Set R&S CMU to internal reference.
 - Measure at REF OUT 1: 10 MHz, level > 1.4 V(pp).

- REF IN signal:**
- Set R&S CMU to external reference.
 - Feed in at REF IN: 52 MHz TTL, (as an alternative +16 dBm from signal)
 - Measure at REF OUT 1: 52 MHz, level > 1.4 V(pp).
 - Measure at REF OUT 1: frequency 52 MHz \pm 1 Hz
 - Feed in at REF IN: 1 MHz TTL, (as an alternative +16 dBm from signal generator).
 - Measure at REF OUT 1: 1 MHz, level > 0.5 V(rms) (1.4 V(pp)).
 - Measure at REF OUT 1: frequency 1 MHz \pm 1 Hz.

REF OUT 2

The level and frequency are checked. The R&S CMU and the frequency counter must be synchronized (test setup REF2).

- REF OUT 2 signal
13 MHz or 10 MHz:**
- Set R&S CMU to external reference.
 - Feed in at REF IN: 10 MHz sinewave, 0.5 V(rms).
 - Set R&S CMU to REF OUT 2 13 MHz or 10 MHz (depending on SW; menu *Connection Control – Sync.*).
 - Measure at REF OUT 2: 13 MHz or 10 MHz, level > 1.0 V(pp).
 - Measure at REF OUT 2: frequency 13 MHz or 10 MHz \pm 1 Hz.

TX Frequency Accuracy

- Preparation: Test setup TX5, but R&S CMU not synchronized with frequency counter/analyzer and no external trigger.
R&S CMU connector RF3 OUT.
- Control: ➤ Set R&S CMU to desired frequency, level 0 dBm.
- Test: ➤ Determine frequency deviation from nominal frequency.

TX Frequency Settling Time

- Preparation: Test setup TX5, in addition trigger cable from R&S CMU (D-sub connector AUX3, pin2) to analyzer.
R&S CMU connector RF3 OUT.
R&S CMU: Ramping off, hopping on, F1 = start freq., F2 = stop freq.
Analyzer: Sweep time 1 ms, Center = stop frequency, FM demodulation, real time off, BW 50 kHz, 1 kHz/Div, external trigger, Slope negative
- Control: ➤ Set R&S CMU to desired frequencies and hopping, level 0 dBm.
- Test: Time from trigger point when the specified offset (< 1 kHz) from the stop frequency is reached.

TX Level Error

- Preparation: Test setup TX1 to TX4 (depending on level range).
- Control: ➤ Set R&S CMU to desired connector, frequency and level (*RF Analyzer must be OFF*).
- Test: ➤ Measure the TX level of the R&S CMU.
- Note:** *The given frequencies and levels are suggested values. Of course, it is also possible to use other values for the measurement.*

VSWR

- Preparation: ➤ Connect (scalar) network analyzer to RF1, RF2, RF3 OUT, RF4 IN one after the other.
Cable losses must be corrected.
- Control: R&S CMU: Switch generator on and set level to minimum (–130 dBm or –90 dBm), switch RF wideband analyzer on (RF1/RF2/RF4 IN).
- Test: ➤ Measure VSWR at 10 MHz, 900 MHz, 1800 MHz, 2700 MHz.

TX Level Settling Time

- Preparation: Test setup TX5, in addition trigger cable from R&S CMU (D-sub connector AUX3, pin2) to analyzer.
 R&S CMU: Connector RF3 OUT 1GHz, Ramping On, Hopping Off.
 Analyzer: Sweep time = 40 μ s, Center = 1 GHz , Span = 0, RBW = 10 MHz, external trigger.
- Control: ➤ Set R&S CMU to frequency = 1 GHz, specified level and ramping mode.
- Test: ➤ The time period from the trigger point to the point in time when the nominal level < 0.5 dB has been reached is measured.

TX Harmonics

- Preparation: Test setup TX5, no external trigger
 Analyzer: Center = 2 x f_{nom} or Center = 3 x f_{nom} , Span = 1 MHz.
- Control: ➤ Set R&S CMU to connector RF1, specified frequency, level = -27 dBm.
- Test: The suppression of the signal at twice or three times the nominal frequency is measured relative to the nominal signal.
- Control: ➤ Set R&S CMU to connector RF2, specified frequency, level = -10 dBm.
- Test: The suppression of the signal at twice or three times the nominal frequency is measured relative to the nominal signal.
- Control: ➤ Set R&S CMU to connector RF3 OUT, specified frequency, level = +10 dBm.
- Test: The suppression of the signal at twice and three times the nominal frequency is measured relative to the nominal signal.

TX Non Harmonics

TX In-Band Spurious Signals

Spurious signals within the specified frequency bands are checked.

- Preparation Test setup TX5, no external trigger
 Analyzer Start/Stop = specified frequency range, RBW = 100 kHz
- Control: ➤ Set R&S CMU to connector RF3 OUT, specified setting frequency, level = 0 dBm.
- Test: The suppression of the signal is measured at the test frequency relative to the set signal.

TX Fixed Spurious Signals

Fixed spurious signals are checked.

- Preparation: Test setup TX5, no external trigger.
Analyzer: Center = specified test frequency, RBW = 100 kHz, Span = 1 MHz.
- Control: ➤ Set R&S CMU to connector RF3 OUT, specified setting frequency, specified level.
- Test: The suppression of the signal is measured at the test frequency relative to the set signal.

TX SSB Phase Noise

- Preparation Test setup TX5, no external trigger
➤ Connect spectrum analyzer or modulation analyzer to RF3 OUT.
- Control: ➤ Set R&S CMU generator to specified RF frequency.
Output level at RF3 OUT 0 dBm,
Analyzer to specified center frequency,
Span = 50 kHz to 5 MHz, RBW = Span/500,
Noise measurement function.
- Test ➤ Measure the phase noise at the specified spacing from the carrier.

TX Residual FM

- Preparation: Test setup TX5, no external trigger.
➤ Connect spectrum analyzer or modulation analyzer to RF1.
- Control: ➤ Set R&S CMU generator to the specified RF frequency.
Output level at RF1 -27 dBm, analyzer to specified center frequency, FM demodulator.
- Test: ➤ The residual FM with the specified weighting is measured.

TX Residual AM

- Preparation: Test setup TX5, no external trigger.
➤ Connect spectrum analyzer or modulation analyzer to RF1.
- Control: ➤ Set R&S CMU generator to specified RF frequency.
Output level at RF1 -27 dBm, analyzer to specified center frequency, AM demodulator.
- Test: ➤ The residual AM with the specified weighting is measured.

TX Carrier/Sideband Suppression, Max. Distortion

The modulation quality of the analog IQ modulator of the R&S CMU is measured.

- Preparation Test setup TX5, no external trigger.
- Connect spectrum analyzer to RF3 OUT.
- Control:
- Set R&S CMU generator to specified RF frequency.
Output level at RF3 OUT, 0 dBm,
 - Switch on RF generator with offset modulation, 300- kHz baseband filter,
 - Set analyzer to center frequency $f_c = 1000$ MHz, Span = 300 kHz / 3 MHz
- Test:
- The suppression of the carrier at f_c is measured relative to the useful sideband signal at $f_c + f_{mod}$.

RX Power Meter (Frequency-Selective)

- Preparation: Test setup RX1, RX2 (depending on level range).
- Control:
- Set R&S CMU to desired RX frequency and level and Input in menu *RF ANALYZER/ GENERATOR*.
Measuring Bandwidth = 1 kHz.
- Test:
- Measure RX level measurement accuracy of R&S CMU.
- Note:** *The given frequencies and levels are suggested values; of course, it is also possible to use other values for the measurement.*

RX Power Meter (Wideband)

- Preparation Test setup RX1, RX2 (depending on level range).
- Control:
- Set R&S CMU to desired RX connector, frequency and level and Input in menu *RF Analyzer/ Generator*.
Measuring Bandwidth = Wide
- Test:
- Measure RX level measurement accuracy of R&S CMU.
- Note:** *The given frequencies and levels are suggested values; of course, it is also possible to use other values for the measurement.*

RX Harmonics

- Preparation: Test setup RX3,
Generator = f_{in} ; level = 0 dBm.
- Control: ➤ Set R&S CMU to connector RF2, *Max Level* = 2 dBm.
- Test: ➤ The suppression of the signal at twice and three times the input frequency is measured relative to the input signal.
- Preparation: Test setup RX3
Generator = f_{in} ; level = -2 dBm
- Control: ➤ Set R&S CMU to connector RF4 IN, *Max Level* = 0 dBm.
- Test: ➤ The suppression of the signal at twice and three times of input frequency is measured relative to the input signal.

RX Spurious Response / Image Rejection

- Preparation: Test setup RX3,
Generator = f_{in} ; level = 0 dBm.
- Control: ➤ Set R&S CMU to connector RF2, *Max Level* = 2 dBm, *Mode* = *Low Distortion*
- Test: ➤ The suppression of the spurious or image signal is measured relative to the input signal.
- Preparation: Test setup RX3,
Generator = f_{in} ; level = -2 dBm.
- Control: ➤ Set R&S CMU to connector RF4 IN, *Max level* = 0 dBm, *Mode* = *Low Distortion*
- Test: The suppression of the spurious or image signal is measured relative to the input signal.

RX SSB Phase Noise

- Preparation: Test setup RX3,
Generator = $f_{CMU} + df$; level = 10 dBm.
- Control: ➤ Set R&S CMU to connector RF2, *Max Level* = 10 dBm and to desired frequency.
➤ Switch on frequency-selective power meter.
- Test: The measurement is taken with a small test bandwidth at different carrier offsets.
- Note:** *The input level is +10 dBm, RBW = 100 Hz
→ Phase noise = measured value -10 dB -21 dB.*

RX Residual FM/AM

- Preparation: Test setup RX4,
Generator = f_{iCMU} ; level = -20 dBm.
- Control:
- Set R&S CMU to connector RF4 IN, *Max Level* = -20 dBm and to desired frequency.
 - Switch on frequency-selective power meter.
- Test: The measurement is taken with an external FM/AM demodulation instrument (FSE with FSE-B7) via the *IF3RXCH1* BNC connector at the rear panel of the R&S CMU.
- Set the FSE to desired frequency, ref. level, AF filters.

RX Dynamic/ Average Noise Level

- Preparation: No signal is fed in, R&S CMU generator is OFF.
- Control: Set R&S CMU to given receive frequency, *Max. Level, Bandwidth, Mode = Low Noise*.
- Test: Use frequency-selective power meter, measurement bandwidth = 1 kHz / 500 kHz, measured value in dB below reference level (*Max. Level*).

Options for R&S CMU200

GSM-MS

The following tests can be carried out only if the GSM-MS (R&S CMU-K2x) software options are installed and enabled by entering a key code.

TX GSM Modulation

Only with options R&S CMU-K21, R&S CMU-K22, R&S CMU-K23 or R&S CMU-K24:

The GSM phase/frequency error of a TX path is measured.

Preparation: Test setup TX5:

- Connect spectrum analyzer FSIQ to RF3 OUT.

Control:

- Set R&S CMU generator to specified RF frequency.

Output level at RF3 OUT 10 dBm
Training Sequence -> GSM0;
Bit Mod. -> PRBS
Transmission -> BURST

Settings at spectrum analyzer FSIQ:

Mode -> *Digital Standards* -> *GSM*

Mode -> *Meas Result* -> *Result_Length* -> 146 (the useful part normally comprises 147 bits, however, the FSIQ can be set to an integer number of bits only and therefore cuts off 0.5 bits at the beginning and at the end of the measurement range)

Trigger -> *Find Sync* -> *ON*

Trigger -> *Sync Pattern* -> *gsm_bts0* (training sequence GSM0)

Trigger -> *Sync Offset* -> 60 symbols

Test:

Phase (rms and peak) and frequency errors are measured according to GSM recommendation.

RX GSM Demodulation

Only with option R&S CMU-K21, R&S CMU-K22, R&S CMU-K23 or R&S CMU-K24:

The GSM phase/frequency error of a RX path is measured.

Preparation:

- Connect GSM signal generator to RF2 (test setup RX3).

The signal generator must be synchronized with the R&S CMU via the 10 MHz reference frequency.

Control:

Signal generator SMIQ: GSM signal at given frequency, level according to table, bursted with the following settings:

Digital Std -> *GSM/EDGE* -> *State* -> *ON*;

Digital Std -> *GSM/EDGE* -> *Select Slot* -> *Burst type* -> *NORM*

Digital Std -> *GSM/EDGE* -> *Select Slot* -> *Slot Level* -> *FULL*

Digital Std -> *GSM/EDGE* -> *Select Slot* -> *Data* -> *PN9*

Digital Std -> *GSM/EDGE* -> *Select Slot* -> *TSC* -> *TSC0*

R&S CMU: GSM Non Signalling, *training sequence* = *GSM 0*, *trigger source* = *IF Power*, *Trigger Level* = *Medium*

Test:

- Measure GSM phase error (rms and peak) as well as frequency error.

CDMA2000

The following tests can be carried out only if the CDMA2000 (R&S CMU-K8x) software options are installed and enabled by entering a key code.

TX CDMA2000 Modulation

Only with options R&S CMU-K83, R&S CMU-K84, R&S CMU-K85 or R&S CMU-K86:

The CDMA2000 modulation parameter of a TX path is measured.

Preparation: Test setup TX5:

- Connect spectrum analyzer FSIQ to RF3 OUT.

Control:

- Set R&S CMU generator to specified RF frequency.

Settings at R&S CMU:

CDMA2000 450 MHz (CDMA2000 Cellular, CDMA2000 PCS, CDMA2000 IMT-2000) Signaling Connection Control

CDMA Power = -7 dBm

Traffic level = OFF, Paging level = OFF, Sync. level = OFF, Pilot level = -7 dB,

OCNS level = OFF

RF3OUT

RF Channel = 1, 2016 CDMA2000 450 MHz

= 1, 777 CDMA2000 Cellular

= 1, 1199 CDMA2000 PCS

= 0, 1199 CDMA2000 IMT-2000

Switch on Generator

Remote (in CDMA2000 NSig):

OUTP:STAT RF3

SOURCE:RFGenerator:LEVEL:OCNS:ENABLE OFF

SOURCE:RFGenerator:FREQUENCY 870.03MHZ

SOURCE:RFGenerator:POWER:CDMA -7

SOURCE:RFGenerator:LEVEL:FPICH -7

SOURCE:RFGenerator:LEVEL:FSYNC OFF

SOURCE:RFGenerator:LEVEL:FPCH OFF

SOURCE:RFGenerator:LEVEL:FFCH OFF

INIT:RFGenerator

Settings at FSIQ 7:

Set Frequency 460.000 MHz, 493.48 MHz CDMA2000 450 MHz

870.03 MHz, 893.31 MHz CDMA2000 Cellular

1930.05 MHz, 1989.95 MHz CDMA2000 PCS

2110.000 MHz, 2169.95 MHz CDMA2000 IMT-2000

Set Reference Level

Rho Factor Measurement , Carrier Suppression

Annotation:

FSIQ can perform this measurement only on one active channel

The R&S CMU CDMA2000 Output level will only be equal to displayed CDMA power with OCNS=AUTO.

Test:

Rho factor and carrier suppression are measured according to CDMA2000 recommendation.

RX CDMA2000 Demodulation

Only with option R&S CMU-K83, R&S CMU-K84, R&S CMU-K85 or R&S CMU-K86:

The CDMA2000 modulation parameter of a RX path is measured.

Preparation: ➤ Connect CDMA2000 signal generator to RF2 (test setup RX3).

CDMA RX Measurement for RC1,2(O-QPSK)

The signal generator must be synchronized with the R&S CMU via the 10 MHz reference frequency.

Control:

Signal Generator SMIQ:

Reset

Set Frequency 450.000 MHz, 483.480 MHz CDMA2000 450 MHz

825.03 MHz, 848.31 MHz CDMA2000 Cellular

1850.05 MHz, 1909.95 MHz CDMA2000 PCS

1920.000 MHz, 1979.950 MHz CDMA2000 IMT-2000

Set Level -10 dBm

Select DIGITAL STD IS95

STATE ON

MODE REV_LINK

TRIGGER MODE AUTO

R&S CMU:

CDMA 800 (CDMA 1900) NSig Analyzer/Generator

RF Channel = 1, 2016 CDMA2000 450 MHz

= 1, 777 CDMA2000 Cellular

= 1, 1199 CDMA2000 PCS

= 0, 1199 CDMA2000 IMT-2000

Analyzer Mode MAN

Expected power -10 dBm (Max Level = input level +6dB, to prevent overload in R&S CMU SW)

RF2

Trigger: FREERUN

Remote:

INP:STAT RF2;

TRIGger[:SEQuence]:SOURce[:OQPSk]FRUN

SENSE:LEVEL:MODE MAN

LEV:MAX -10

[SENSe]:RFANalyzer:FREQuency [MHz]

READ[:SCALar]:MODulation:MQuality:OQPSk?

READ[:SCALar]:MODulation:MQuality:OQPSk?

<i><MSPower></i>	<i>{Value}</i>	<i>dBm</i>
<i><Waveform Quality></i>	<i>{Value}</i>	
<i><CarrierFrequencyError></i>	<i>{Value}</i>	<i>Hz</i>
<i><TransmitTimeError></i>	<i>{Value}</i>	<i>s</i>
<i><CarrierFeedthrough></i>	<i>{Value}</i>	<i>dB</i>
<i>RESERVED</i>	<i>NAN</i>	
<i><SidebandSuppresLower></i>	<i>{Value}</i>	<i>dB</i>
<i><SidebandSuppresUpper></i>	<i>{Value}</i>	<i>dB</i>
<i><Bursts Out Of Tolerance></i>	<i>{Value}</i>	<i>%</i>

Test:

➤ Measure waveform quality as well as frequency measurement error.

WCDMA

The following tests can be carried out only if the WCDMA (R&S CMU-K66) software options are installed and enabled by entering a key code.

TX WCDMA Modulation

Only with option R&S CMU-K66:

The WCDMA modulation parameter of a TX path is measured.

Preparation: Test setup TX5:

- Connect spectrum analyzer FSIQ to RF2 and RF3 OUT.

Control:

- Set R&S CMU generator to specified RF frequency.

Settings at R&S CMU:

R&S CMU-WCDMA-generator:

Total level = CPICH-level

relative level : SCHs = -35dB, P-CCPCH = -35 dB, DPDCH = 0dB,

DPCH/DPDCH = 0dB, PICH level = -35dB

DPCH Codechannel = 4 (R&S CMU SW Base >= V3.07 necessary)

Generator-Mode: 3GPP Reference Measurement Channel 12.2kbit/s and 384 kbit/s (entspricht Symbolrate 480ksps)

Settings at FSIQ 7:

WCDMA BTS Analyser, Code Domain Power,

Display-Result: Result summary

Select Channel Number:

16 für 12.2 kbit/s, 256 für 384 kbit/s

Code Channel Conf: 480ksps für 384 kbit/s

Test:

Global EVM are measured.

RX WCDMA Demodulation

Only with option R&S CMU-K65:

The WCDMA demodulation quality of a RX path is measured.

Preparation:

- Connect WCDMA signal generator to RF2 and RF4 IN (test setup RX3).

WCDMA RX Measurement

The signal generator must be synchronized with the R&S CMU via the 10 MHz reference frequency.

Control:

- Set R&S CMU analyzer and SMIQ to specified RF frequency.

Signal Generator SMIQ:

Signal Typ 2

Low_EVM-Mode

R&S CMU:

Application WCDMA

RF mode = Manual

RF Attenuation = Low Noise

Statistical Count = 10

Test:

- Measure EVM rms, I/Q origin offset, I/Q imbalance, carrier frequency error as well as peak code domain error.

Function Test with Mobile Stations (R&S CMU200)

GSM mobile test

Only with Option R&S CMU-K21, R&S CMU-K22, R&S CMU- K23 or R&S CMU-K24.

Location Update
Call to MS
Call Release
Call from MS
Echo test
Power ramp, Phase/Frequency error measurement
Handover GSM900/1800

CDMA mobile test

Only with Option R&S CMU-K81, R&S CMU-K82.

Location Update
Call to MS
Call Release
Call from MS
Echo test

CDMA2000 mobile test

Only with Option R&S CMU-K83, R&S CMU-K84,R&S CMU-K85, R&S CMU-K86.

Location Update
Call to MS
Call Release
Call from MS
Echo test

IS136-mobile test

Only with Option R&S CMU-K27, R&S CMU-K28.

Location Update
Call to MS
Call Release
Call from MS
Echo test

AMPS-mobile test

Only with Option R&S CMU-K29.

Location Update
Call to MS
Call Release
Call from MS
Echo test

Test Report

ROHDE & SCHWARZ	Universal Radiocommunication Tester R&S CMU	1100.0008
Serial number:		
Test person:		
Date:		
Signature:		

Table 1-2 Test report

Item No.	Description	Measurement to section	Min.	Actual	Max.	Measurement uncertainty	Unit
	Ambient temperature during calibration		23		26		°C
General Tests							
	CONTINUOUS SELFTEST		Passed		passed		
	1→ 4/3→ 2 RF LOOP TEST		Passed		passed		
	Adjusting +5 V DC REFERENCE VOLTAGE	Chapter 2	4.999		5.001		mV
	Adjusting TCXO 10 MHz at RF3 OUT 1 GHz (if none of the options R&S CMU-B11 or R&S CMU-B12 is installed)	Chapter 2	-50		+50		Hz
	Adjusting R&S CMU-B11 OCXO 10 MHz at RF3 OUT 1GHz (if option R&S CMU-B11 is installed)	Chapter 2	-10		+5		Hz
	Adjusting R&S CMU-B12 OCXO 10 MHz at RF3 OUT 1GHz (if option R&S CMU-B12 is installed)	Chapter 2	-10		+5		Hz
	REF IN 52 MHz	REF IN	-1		+1		Hz
	REF IN 1 MHz		-1		+1		Hz
	REF IN 10 MHz +50 Hz		-1		+1		Hz
	REF IN 10 MHz -50 Hz		-1		+1		Hz
	REF OUT 1 Int 10 MHz	REF OUT 1	1.4		5		V(pp)
	REF OUT 1 52 MHz		1.4		5		V(pp)
	REF OUT 1 52 MHz		-1		+1		Hz
	REF OUT 1 1 MHz		1.4		5		V(pp)
	REF OUT 1 1 MHz		-1		+1		Hz

Item No.	Description	Measurement to section	Min.	Actual	Max.	Measurement uncertainty	Unit
	REF OUT 2 13 MHz or 10 MHz	REF OUT 2	1		5		V(pp)
	REF OUT 2 13 MHz or 10 MHz		-1		+1		Hz
TX Frequency Accuracy							
	TX Frequency accuracy 2200 MHz	TX Frequency accuracy	-2200 -220 -11		+2200 (TCXO), +220 (B11), +11 (B12)		Hz
TX Frequency Settling							
	TX frequency settling time F1 = 100 MHz ->F2 = 200 MHz to <1 kHz	TX Frequency settling			400		µs
	TX frequency settling time F1 = 1800 MHz ->F2 = 1900 MHz to <1 kHz				400		µs
	TX frequency settling time F1 = 2200 MHz ->F2 = 2100 MHz to <1 kHz				400		µs
	TX frequency settling time F1 = 100 MHz ->F2 = 2200 MHz to <1 kHz				400		µs
	TX frequency settling time F1 = 2000 MHz ->F2 = 100 MHz to <1 kHz				400		µs
VSWR							
	VSWR RF1 10 MHz	VSWR			1.2		
	VSWR RF1 900 MHz				1.2		
	VSWR RF1 1800 MHz				1.2		
	VSWR RF1 2700 MHz				1.6		
	VSWR RF2 10 MHz				1.2		
	VSWR RF2 900 MHz				1.2		
	VSWR RF2 1800 MHz				1.2		
	VSWR RF2 2700 MHz				1.6		
	VSWR RF3 OUT 10 MHz				1.5		
	VSWR RF3 OUT 900 MHz				1.5		
	VSWR RF3 OUT 1800 MHz				1.5		
	VSWR RF3 OUT 2700 MHz				1.7		
	VSWR RF4 IN 10 MHz				1.5		
	VSWR RF4 IN 900 MHz				1.5		
	VSWR RF4 IN 1800 MHz				1.5		
	VSWR RF4 IN 2700 MHz				1.6		

Item No.	Description	Measurement to section	Min.	Actual	Max.	Measurement uncertainty	Unit
TX Level Settling Time							
	TX Level settling time at P = +10 dBm to $\Delta P = 0.5$ dB	TX level settling time			4		μ s
	TX Level settling time at P = -20 dBm to $\Delta P = 0.5$ dB				4		μ s
	TX Level settling time at P = -50 dBm to $\Delta P = 0.5$ dB				4		μ s
TX Harmonics							
	TX 2nd harmonic at RF2 at carrier frequency = 10 MHz	TX harmonics			-30		dBc
	TX 2nd harmonic at RF2 at carrier frequency = 900 MHz				-30		dBc
	TX 2nd harmonic at RF2 at carrier frequency = 1800 MHz				-30		dBc
	TX 2nd harmonic at RF2 at carrier frequency = 2200 MHz				-30		dBc
	TX 3rd harmonic at RF2 at carrier frequency = 10 MHz				-30		dBc
	TX 3rd harmonic at RF2 at carrier frequency = 900 MHz				-30		dBc
	TX 3rd harmonic at RF2 at carrier frequency = 1800 MHz				-30		dBc
	TX 3rd harmonic at RF2 at carrier frequency = 2200 MHz				-30		dBc
	TX 2nd harmonic at RF3 OUT at carrier frequency = 10 MHz				-20		dBc
	TX 2nd harmonic at RF3 OUT at carrier frequency = 900 MHz				-20		dBc
	TX 2nd harmonic at RF3 OUT at carrier frequency = 1800 MHz				-20		dBc
	TX 2nd harmonic at RF3 OUT at carrier frequency = 2200 MHz				-20		dBc
	TX 3rd harmonic at RF3 OUT at carrier frequency = 10 MHz				-20		dBc
	TX 3rd harmonic at RF3 OUT at carrier frequency = 900 MHz				-20		dBc
	TX 3rd harmonic at RF3 OUT at carrier frequency = 1800 MHz				-20		dBc
	TX 3rd harmonic at RF3 OUT at carrier frequency = 2200 MHz				-20		dBc
TX In-band Spurious Responses							
	TX In-band spurious R&S CMU setting = 460.9 MHz search freq. \pm (5 to 500) kHz from carrier	TX in-band spurious responses			-40		dBc

Item No.	Description	Measurement to section	Min.	Actual	Max.	Measurement uncertainty	Unit
	TX In-band spurious R&S CMU setting = 468.1 MHz search freq. \pm (5 to 500) kHz from carrier				-40		dBc
	TX In-band spurious R&S CMU setting = 489.3 MHz search freq. \pm (5 to 500) kHz from carrier				-40		dBc
	TX In-band spurious R&S CMU setting = 496.5 MHz search freq. \pm (5 to 500) kHz from carrier				-40		dBc
	TX In-band spurious R&S CMU setting = 925.5 MHz search freq. \pm (5 to 500) kHz from carrier				-40		dBc
	TX In-band spurious R&S CMU setting = 960.5 MHz search freq. \pm (5 to 500) kHz from carrier				-40		dBc
	TX In-band spurious R&S CMU setting = 1805.5 MHz search freq. \pm (5 to 500) kHz from carrier				-40		dBc
	TX In-band spurious R&S CMU setting = 1880.5 MHz search freq. \pm (5 to 500) kHz from carrier				-40		dBc
	TX In-band spurious R&S CMU setting = 869.5 MHz search freq. \pm (5 to 500) kHz from carrier				-40		dBc
	TX In-band spurious R&S CMU setting = 894.5 MHz search freq. \pm (5 to 500) kHz from carrier				-40		dBc
	TX In-band spurious R&S CMU setting = 1930.5 MHz search freq. \pm (5 to 500) kHz from carrier				-40		dBc
	TX In-band spurious R&S CMU setting = 1990.5 MHz search freq. \pm (5 to 500) kHz from carrier				-40		dBc
	TX In-band spurious R&S CMU setting = 1920.5 MHz search freq. \pm (5 to 500) kHz from carrier				-40		dBc
	TX In-band spurious R&S CMU setting = 1980.5 MHz search freq. \pm (5 to 500) kHz from carrier				-40		dBc
	TX In-band spurious R&S CMU setting = 2110.5 MHz search freq. \pm (5 to 500) kHz from carrier				-40		dBc

Item No.	Description	Measurement to section	Min.	Actual	Max.	Measurement uncertainty	Unit
	TX In-band spurious R&S CMU setting = 2170.5 MHz search freq. \pm (5 to 500) kHz from carrier				-40		dBc
TX Fixed Spurious Responses							
	TX fixed spurious, R&S CMU setting = 14.35 MHz search freq. 13.85 MHz Level = -20 dBm	TX fixed spurious			-40		dBc
	TX fixed spurious, R&S CMU setting = 37.4333 MHz search freq. 36.9333 MHz Level = -20 dBm				-40		dBc
	TX fixed spurious, R&S CMU setting = 42.05 MHz search freq. 41.55 MHz Level = -20 dBm				-40		dBc
	TX fixed spurious, R&S CMU setting = 111.3 MHz search freq. 110.8 MHz Level = -20 dBm				-40		dBc
	TX fixed spurious, R&S CMU setting = 222.1 MHz search freq. 221.6 MHz Level = -20 dBm				-40		dBc
	TX fixed spurious, R&S CMU setting = 332.9 MHz search freq. 332.4 MHz Level = -20 dBm				-40		dBc
	TX fixed spurious, R&S CMU setting = 501.87 MHz search freq. 501.37 MHz Level = -20 dBm				-40		dBc
	TX fixed spurious, R&S CMU setting = 1330.1 MHz search freq. 1329.6 MHz Level = 0 dBm				-40		dBc
	TX fixed spurious, R&S CMU setting = 100 MHz search freq. 1917.12 MHz Level = 0 dBm				-40		dBc
	TX fixed spurious, R&S CMU setting = 1300 MHz search freq. 2142.08 MHz Level = 0 dBm				-40		dBc
	TX fixed spurious, R&S CMU setting = 2200 MHz search freq. 3042.08 MHz Level = 0 dBm				-40		dBc

Item No.	Description	Measurement to section	Min.	Actual	Max.	Measurement uncertainty	Unit
	TX fixed spurious, R&S CMU setting = 100 MHz search freq. 86.15 MHz Level = +10 dBm				-40		dBc
	TX fixed spurious, R&S CMU setting = 100 MHz search freq. 113.85 MHz Level = +10 dBm				-40		dBc
	TX fixed spurious, R&S CMU setting = 100 MHz search freq. 1817.12 MHz Level = +10 dBm				-40		dBc
	TX fixed spurious, R&S CMU setting = 100 MHz search freq. 1917.12 MHz Level = +10 dBm				-40		dBc
	TX fixed spurious, R&S CMU setting = 900 MHz search freq. 917.12 MHz Level = +10 dBm				-40		dBc
	TX fixed spurious, R&S CMU setting = 900 MHz search freq. 1817.12 MHz Level = +10 dBm				-40		dBc
	TX fixed spurious, R&S CMU setting = 1199 MHz search freq. 618.12 MHz Level = +10 dBm				-40		dBc
	TX fixed spurious, R&S CMU setting = 1199 MHz search freq. 1817.12 MHz Level = +10 dBm				-40		dBc
	TX fixed spurious, R&S CMU setting = 1201 MHz search freq. 842.08 MHz Level = +10 dBm				-40		dBc
	TX fixed spurious, R&S CMU setting = 1201 MHz search freq. 1684.16 MHz Level = +10 dBm				-40		dBc
	TX fixed spurious, R&S CMU setting = 1201 MHz search freq. 2043.08 MHz Level = +10 dBm				-40		dBc
	TX fixed spurious, R&S CMU setting = 1201 MHz search freq. 2885.16 MHz Level = +10 dBm				-40		dBc

Item No.	Description	Measurement to section	Min.	Actual	Max.	Measurement uncertainty	Unit
	TX fixed spurious, R&S CMU setting = 1700 MHz search freq. 842.08 MHz Level = +10 dBm				-40		dBc
	TX fixed spurious, R&S CMU setting = 1700 MHz search freq. 2542.08 MHz Level = +10 dBm				-40		dBc
	TX fixed spurious, R&S CMU setting = 1800 MHz search freq. 842.08 MHz Level = +10 dBm				-40		dBc
	TX fixed spurious, R&S CMU setting = 1800 MHz search freq. 1684.16 MHz Level = +10 dBm				-40		dBc
	TX fixed spurious, R&S CMU setting = 1800 MHz search freq. 2642.08 MHz Level = +10 dBm				-40		dBc
	TX fixed spurious, R&S CMU setting = 1900 MHz search freq. 842.08 MHz Level = +10 dBm				-40		dBc
	TX fixed spurious, R&S CMU setting = 1900 MHz search freq. 1057.92 MHz Level = +10 dBm				-40		dBc
	TX fixed spurious, R&S CMU setting = 1900 MHz search freq. 1684.16 MHz Level = +10 dBm				-40		dBc
	TX fixed spurious, R&S CMU setting = 1900 MHz search freq. 2742.08 MHz Level = +10 dBm				-40		dBc
	TX fixed spurious, R&S CMU setting = 2199 MHz search freq. 842.08 MHz Level = +10 dBm				-40		dBc
	TX fixed spurious, R&S CMU setting = 2199 MHz search freq. 1356.92 MHz Level = +10 dBm				-40		dBc
	TX fixed spurious, R&S CMU setting = 2199 MHz search freq. 1684.16 MHz Level = +10 dBm				-40		dBc

Item No.	Description	Measurement to section	Min.	Actual	Max.	Measurement uncertainty	Unit
	TX fixed spurious, R&S CMU setting = 2199 MHz search freq. 3041.08 MHz Level = +10 dBm				-40		dBc
TX SSB Phase Noise							
	TX SSB phase noise f = 100 MHz, $\Delta f = 20$ kHz	TX SSB phase noise			-100		dBc
	TX SSB phase noise f = 100 MHz, $\Delta f = 250$ kHz				-110		dBc
	TX SSB phase noise f = 100 MHz, $\Delta f = 400$ kHz				-110		dBc
	TX SSB phase noise f = 100 MHz, $\Delta f = 1990$ kHz				-110		dBc
	TX SSB phase noise f = 945 MHz, $\Delta f = 20$ kHz				-100		dBc
	TX SSB phase noise f = 945 MHz, $\Delta f = 250$ kHz				-110		dBc
	TX SSB phase noise f = 945 MHz, $\Delta f = 400$ kHz				-110		dBc
	TX SSB phase noise f = 945 MHz, $\Delta f = 1990$ kHz				-110		dBc
	TX SSB phase noise f = 1850 MHz, $\Delta f = 20$ kHz				-100		dBc
	TX SSB phase noise f = 1850 MHz, $\Delta f = 250$ kHz				-110		dBc
	TX SSB phase noise f = 1850 MHz, $\Delta f = 400$ kHz				-110		dBc
	TX SSB phase noise f = 1850 MHz, $\Delta f = 1990$ kHz				-110		dBc
	TX SSB phase noise f = 2200 MHz, $\Delta f = 20$ kHz				-100		dBc
	TX SSB phase noise f = 2200 MHz, $\Delta f = 250$ kHz				-110		dBc
	TX SSB phase noise f = 2200 MHz, $\Delta f = 400$ kHz				-110		dBc
	TX SSB phase noise f = 2200 MHz, $\Delta f = 1990$ kHz				-110		dBc
TX Residual FM							
	TX Residual FM at 1000 MHz 30 Hz to 15 kHz, rms				50		Hz
	TX Residual FM at 1000 MHz 30 Hz to 15 kHz, peak				200		Hz
	TX Residual FM at 1000 MHz CCITT, rms				5		Hz
	TX Residual FM at 2000 MHz 30 Hz to 15 kHz, rms				50		Hz

Item No.	Description	Measurement to section	Min.	Actual	Max.	Measurement uncertainty	Unit
	TX Residual FM at 2000 MHz 30 Hz to 15 kHz, peak				200		Hz
	TX Residual FM at 2000 MHz CCITT, rms				5		Hz
TX Residual AM							
	TX Residual AM at 500 MHz CCITT, rms				0.02		%
	TX Residual AM at 1000 MHz CCITT, rms				0.02		%
	TX Residual AM at 1500 MHz CCITT, rms				0.02		%
	TX Residual AM at 2200 MHz CCITT, rms				0.02		%
TX Modulation characteristics							
	TX Modulation characteristics carrier suppression, $f_{mod} = 10$ kHz, $f_{RF} = 1000$ MHz				-40		dBc
	TX Modulation characteristics carrier suppression, $f_{mod} = -20$ kHz, $f_{RF} = 1000$ MHz				-40		dBc
	TX Modulation characteristics carrier suppression, $f_{mod} = 20$ kHz, $f_{RF} = 1000$ MHz				-40		dBc
	TX Modulation characteristics carrier suppression, $f_{mod} = 30$ kHz, $f_{RF} = 1000$ MHz				-40		dBc
	TX Modulation characteristics carrier suppression, $f_{mod} = 60$ kHz, $f_{RF} = 1000$ MHz				-40		dBc
	TX Modulation characteristics carrier suppression, $f_{mod} = 100$ kHz, $f_{RF} = 1000$ MHz				-40		dBc
	TX Modulation characteristics carrier suppression, $f_{mod} = 135$ kHz, $f_{RF} = 1000$ MHz				-40		dBc
	TX Modulation characteristics carrier suppression, $f_{mod} = -135$ kHz, $f_{RF} = 1000$ MHz				-40		dBc
RX Harmonics							
	RX 2nd harmonic at RF2, $f_{IN} = 50$ MHz, R&S CMU frequency = 100 MHz	RX harmonics			-30		dBc
	RX 2nd harmonic at RF2 $f_{IN} = 600$ MHz, R&S CMU frequency = 1200 MHz				-30		dBc
	RX 2nd harmonic at RF2, $f_{IN} = 625$ MHz, R&S CMU frequency = 1250 MHz				-30		dBc
	RX 2nd harmonic at RF2, $f_{IN} = 1100$ MHz, R&S CMU frequency = 2200 MHz				-30		dBc

Item No.	Description	Measurement to section	Min.	Actual	Max.	Measurement uncertainty	Unit
	RX 3rd harmonic at RF2 , $f_{IN} = 50$ MHz, R&S CMU frequency = 150 MHz				-30		dBc
	RX 3rd harmonic at RF2 , $f_{IN} = 400$ MHz, R&S CMU frequency = 1200 MHz				-30		dBc
	RX 3rd harmonic at RF2 , $f_{IN} = 420$ MHz, R&S CMU frequency = 1260 MHz				-30		dBc
	RX 3rd harmonic at RF2 , $f_{IN} = 730$ MHz, R&S CMU frequency = 2190 MHz				-30		dBc
	RX 2nd harmonic at RF4 IN , $f_{IN} = 50$ MHz, R&S CMU frequency = 100 MHz				-20		dBc
	RX 2nd harmonic at RF4 IN , $f_{IN} = 600$ MHz, R&S CMU frequency = 1200 MHz				-20		dBc
	RX 2nd harmonic at RF4 IN , $f_{IN} = 625$ MHz, R&S CMU frequency = 1250 MHz				-20		dBc
	RX 2nd harmonic at RF4 IN , $f_{IN} = 1100$ MHz, R&S CMU frequency = 2200 MHz				-20		dBc
	RX 3rd harmonic at RF4 IN , $f_{IN} = 50$ MHz, R&S CMU frequency = 150 MHz				-20		dBc
	RX 3rd harmonic at RF4 IN , $f_{IN} = 400$ MHz, R&S CMU frequency = 1200 MHz				-20		dBc
	RX 3rd harmonic at RF4 IN , $f_{IN} = 420$ MHz, R&S CMU frequency = 1260 MHz				-20		dBc
	RX 3rd harmonic at RF4 IN , $f_{IN} = 730$ MHz, R&S CMU frequency = 2190 MHz				-20		dBc
RX Spurious Response							
	RX inherent spurious response at RF2, $f_{IN} = 1876.03$ MHz, R&S CMU frequency = 903 MHz	RX Spurious response			-50		dBc
	RX inherent spurious response at RF2, $f_{IN} = 881.6$ MHz, R&S CMU frequency = 903 MHz				-50		dBc
	RX inherent spurious response at RF2, $f_{IN} = 843.085$ MHz, R&S CMU frequency = 200 MHz				-50		dBc
	RX inherent spurious response at RF2, $f_{IN} = 421.5425$ MHz, R&S CMU frequency = 200 MHz				-50		dBc
	RX inherent spurious response at RF2, $f_{IN} = 908.0575$ MHz, R&S CMU frequency = 300 MHz				-50		dBc
	RX inherent spurious response at RF2, $f_{IN} = 605.3716667$ MHz, R&S CMU frequency = 300 MHz				-50		dBc

Item No.	Description	Measurement to section	Min.	Actual	Max.	Measurement uncertainty	Unit
	RX inherent spurious response at RF2, $f_{IN} = 454.02875$ MHz, R&S CMU frequency = 300 MHz				-50		dBc
	RX inherent spurious response at RF2, $f_{IN} = 500$ MHz, R&S CMU frequency = 505.35 MHz				-50		dBc
	RX inherent spurious response at RF2, $f_{IN} = 968.0575$ MHz, R&S CMU frequency = 60 MHz				-50		dBc
	RX inherent spurious response at RF2, $f_{IN} = 1200$ MHz, R&S CMU frequency = 291.9425 MHz				-50		dBc
	RX inherent spurious response at RF2, $f_{IN} = 645.3716667$ MHz, R&S CMU frequency = 60 MHz				-50		dBc
	RX inherent spurious response at RF2, $f_{IN} = 1200$ MHz, R&S CMU frequency = 891.9425 MHz				-50		dBc
	RX inherent spurious response at RF2, $f_{IN} = 1936.115$ MHz, R&S CMU frequency = 60 MHz				-50		dBc
	RX inherent spurious response at RF2, $f_{IN} = 2200$ MHz, R&S CMU frequency = 191.9425 MHz				-50		dBc
	RX inherent spurious response at RF2, $f_{IN} = 1226.97$ MHz, R&S CMU frequency = 2200 MHz				-50		dBc
	RX inherent spurious response at RF2, $f_{IN} = 1821.4$ MHz, R&S CMU frequency = 1800 MHz				-50		dBc
	RX inherent spurious response at RF2, $f_{IN} = 2936.17$ MHz, R&S CMU frequency = 1250 MHz				-50		dBc
	RX inherent spurious response at RF2, $f_{IN} = 843.085$ MHz, R&S CMU frequency = 2200 MHz				-50		dBc
	RX inherent spurious response at RF2, $f_{IN} = 421.5425$ MHz, R&S CMU frequency = 2200 MHz				-50		dBc
	RX inherent spurious response at RF2, $f_{IN} = 281.0283333$ MHz, R&S CMU frequency = 2200 MHz				-50		dBc
	RX inherent spurious response at RF2, $f_{IN} = 1816.115$ MHz, R&S CMU frequency = 2200 MHz				-50		dBc
	RX inherent spurious response at RF2, $f_{IN} = 908.0575$ MHz, R&S CMU frequency = 2200 MHz				-50		dBc
	RX inherent spurious response at RF2, $f_{IN} = 605.3716667$ MHz, R&S CMU frequency = 2200 MHz				-50		dBc
	RX inherent spurious response at RF2, $f_{IN} = 1671.5425$ MHz, R&S CMU frequency = 1250 MHz				-50		dBc

Item No.	Description	Measurement to section	Min.	Actual	Max.	Measurement uncertainty	Unit
	RX inherent spurious response at RF2, $f_{IN} = 2200$ MHz, R&S CMU frequency = 1778.4575 MHz				-50		dBc
	RX inherent spurious response at RF2, $f_{IN} = 1812.056667$ MHz, R&S CMU frequency = 1250 MHz				-50		dBc
	RX inherent spurious response at RF2, $f_{IN} = 1681.5425$ MHz, R&S CMU frequency = 1680 MHz				-50		dBc
	RX inherent spurious response at RF2, $f_{IN} = 1468.085$ MHz, R&S CMU frequency = 1250 MHz				-50		dBc
	RX inherent spurious response at RF2, $f_{IN} = 1683.085$ MHz, R&S CMU frequency = 1680 MHz				-50		dBc
	RX inherent spurious response at RF2, $f_{IN} = 1943.085$ MHz, R&S CMU frequency = 2200 MHz				-50		dBc
	RX inherent spurious response at RF2, $f_{IN} = 978.7233333$ MHz, R&S CMU frequency = 1250 MHz				-50		dBc
	RX inherent spurious response at RF2, $f_{IN} = 1295.39$ MHz, R&S CMU frequency = 2200 MHz				-50		dBc
	RX inherent spurious response at RF2, $f_{IN} = 1210.8433333$ MHz, R&S CMU frequency = 1210.7433333 MHz				-50		dBc
	RX inherent spurious response at RF2, $f_{IN} = 1262.31375$ MHz, R&S CMU frequency = 1260 MHz				-50		dBc
	RX inherent spurious response at RF4 IN, $f_{IN} = 968.0575$ MHz, R&S CMU frequency = 60 MHz				-50		dBc
	RX inherent spurious response at RF4 IN, $f_{IN} = 1200$ MHz, R&S CMU frequency = 291.9425 MHz				-50		dBc
	RX inherent spurious response at RF4 IN, $f_{IN} = 645.3716667$ MHz, R&S CMU frequency = 60 MHz				-50		dBc
	RX inherent spurious response at RF4 IN, $f_{IN} = 1200$ MHz, R&S CMU frequency = 891.9425 MHz				-50		dBc
	RX inherent spurious response at RF4 IN, $f_{IN} = 1936.115$ MHz, R&S CMU frequency = 60 MHz				-50		dBc
	RX inherent spurious response at RF4 IN, $f_{IN} = 2200$ MHz, R&S CMU frequency = 191.9425 MHz				-50		dBc
	RX inherent spurious response at RF4 IN, $f_{IN} = 1671.5425$ MHz, R&S CMU frequency = 1250 MHz				-50		dBc
	RX inherent spurious response at RF4 IN, $f_{IN} = 2200$ MHz, R&S CMU frequency = 1778.4575 MHz				-50		dBc

Item No.	Description	Measurement to section	Min.	Actual	Max.	Measurement uncertainty	Unit
	RX inherent spurious response at RF4 IN, $f_{IN} = 1812.056667$ MHz, R&S CMU frequency = 1250 MHz				-50		dBc
	RX inherent spurious response at RF4 IN, $f_{IN} = 1681.5425$ MHz, R&S CMU frequency = 1680 MHz				-50		dBc
	RX inherent spurious response at RF4 IN, $f_{IN} = 1468.085$ MHz, R&S CMU frequency = 1250 MHz				-50		dBc
	RX inherent spurious response at RF4 IN, $f_{IN} = 1683.085$ MHz, R&S CMU frequency = 1680 MHz				-50		dBc
	RX inherent spurious response at RF4 IN, $f_{IN} = 1943.085$ MHz, R&S CMU frequency = 2200 MHz				-50		dBc
	RX inherent spurious response at RF4 IN, $f_{IN} = 978.7233333$ MHz, R&S CMU frequency = 1250 MHz				-50		dBc
	RX inherent spurious response at RF4 IN, $f_{IN} = 1295.39$ MHz, R&S CMU frequency = 2200 MHz				-50		dBc
	RX inherent spurious response at RF4 IN, $f_{IN} = 1210.8433333$ MHz, R&S CMU frequency = 1210.7433333 MHz				-50		dBc
	RX inherent spurious response at RF4 IN, $f_{IN} = 1262.31375$ MHz, R&S CMU frequency = 1260 MHz				-50		dBc
RX SSB Phase Noise							
	RX SSB phase noise at RF2 $f = 100$ MHz, $\Delta f = +20$ kHz	RX SSB phase noise			-100		
	RX SSB phase noise at RF2 $f = 100$ MHz, $\Delta f = +250$ kHz				-110		
	RX SSB phase noise at RF2 $f = 100$ MHz, $\Delta f = +400$ kHz				-118		
	RX SSB phase noise at RF2 $f = 100$ MHz, $\Delta f = +1990$ kHz				-118		
	RX SSB phase noise at RF2 $f = 945$ MHz, $\Delta f = +20$ kHz				-100		dBc/Hz
	RX SSB phase noise at RF2 $f = 945$ MHz, $\Delta f = +250$ kHz				-110		dBc/Hz
	RX SSB phase noise at RF2 $f = 945$ MHz, $\Delta f = +400$ kHz				-118		dBc/Hz
	RX SSB phase noise at RF2 $f = 945$ MHz, $\Delta f = +1990$ kHz				-118		dBc/Hz
	RX SSB phase noise at RF2 $f = 1850$ MHz, $\Delta f = -20$ kHz				-100		dBc/Hz
	RX SSB phase noise at RF2 $f = 1850$ MHz, $\Delta f = -250$ kHz				-110		dBc/Hz
	RX SSB phase noise at RF2 $f = 1850$ MHz, $\Delta f = -400$ kHz				-118		dBc/Hz

Item No.	Description	Measurement to section	Min.	Actual	Max.	Measurement uncertainty	Unit
	RX SSB phase noise at RF2 f = 1850 MHz, $\Delta f = -1990$ kHz				-118		dBc/Hz
	RX SSB phase noise at RF2 f = 2200 MHz, $\Delta f = -20$ kHz				-100		dBc/Hz
	RX SSB phase noise at RF2 f = 2200 MHz, $\Delta f = -250$ kHz				-110		dBc/Hz
	RX SSB phase noise at RF2 f = 2200 MHz, $\Delta f = -400$ kHz				-118		dBc/Hz
	RX SSB phase noise at RF2 f = 2200 MHz, $\Delta f = -1990$ kHz				-118		dBc/Hz
RX Residual FM/AM							
	RX Residual FM at 500 MHz at RF4 IN, -20 dBm 30Hz to 15 kHz, rms	RX residual FM/AM			50		Hz
	RX Residual FM at 500 MHz at RF4 IN, -20 dBm 30Hz to 15 kHz, peak				200		Hz
	RX Residual FM at 500 MHz at RF4 IN, -20 dBm CCITT, rms				5		Hz
	RX Residual AM at 500 MHz at RF4 IN, -20 dBm CCITT, rms				0.02		%
	RX Residual FM at 900 MHz at RF4 IN, -20 dBm 30Hz to 15 kHz, rms				50		Hz
	RX Residual FM at 900 MHz at RF4 IN, -20 dBm 30Hz to 15 kHz, peak				200		Hz
	RX Residual FM at 900 MHz at RF4 IN, -20 dBm CCITT, rms				5		Hz
	RX Residual AM at 900 MHz at RF4 IN, -20 dBm CCITT, rms				0.02		%
	RX Residual FM at 1900 MHz at RF4 IN, -20 dBm 30Hz to 15 kHz, rms				50		Hz
	RX Residual FM at 1900 MHz at RF4 IN, -20 dBm 30Hz to 15 kHz, peak				200		Hz
	RX Residual FM at 1900 MHz at RF4 IN, -20 dBm CCITT, rms				5		Hz
	RX Residual AM at 1900 MHz at RF4 IN, -20 dBm CCITT, rms				0.02		%
	RX Residual FM at 2100 MHz at RF4 IN, -20 dBm 30Hz to 15 kHz, rms				50		Hz

Item No.	Description	Measurement to section	Min.	Actual	Max.	Measurement uncertainty	Unit
	RX Residual FM at 2100 MHz at RF4 IN, -20 dBm 30Hz to 15 kHz, peak				200		Hz
	RX Residual FM at 2100 MHz at RF4 IN, -20 dBm CCITT, rms				5		Hz
	RX Residual AM at 2100 MHz at RF4 IN, -20 dBm CCITT, rms				0.02		%
	RX Residual FM at 2500 MHz at RF4 IN, -20 dBm 30Hz to 15 kHz, rms				50		Hz
	RX Residual FM at 2500 MHz at RF4 IN, -20 dBm 30Hz to 15 kHz, peak				200		Hz
	RX Residual FM at 2500 MHz at RF4 IN, -20 dBm CCITT, rms				5		Hz
	RX Residual AM at 2500 MHz at RF4 IN, -20 dBm CCITT, rms				0.02		%

RX Average Noise Level

	RX average noise level RF1, RBW = 1 kHz, expPow = 47 dBm, f = 10 MHz	RX average noise level			-100		dBc
	RX average noise level RF1, RBW = 1 kHz, expPow = 47 dBm, f = 500 MHz				-100		dBc
	RX average noise level RF1, RBW = 1 kHz, expPow = 47 dBm, f = 1000 MHz				-100		dBc
	RX average noise level RF1, RBW = 1 kHz, expPow = 47 dBm, f = 1500 MHz				-100		dBc
	RX average noise level RF1, RBW = 1 kHz, expPow = 47 dBm, f = 2200 MHz				-100		dBc
	RX average noise level RF1, RBW = 1 kHz, expPow = 47 dBm, f = 2700 MHz				-95		dBc
	RX average noise level RF1, RBW = 1 kHz, expPow = 10 dBm, f = 10 MHz				-100		dBc
	RX average noise level RF1, RBW = 1 kHz, expPow = 10 dBm, f = 500 MHz				-100		dBc
	RX average noise level RF1, RBW = 1 kHz, expPow = 10 dBm, f = 1000 MHz				-100		dBc
	RX average noise level RF1, RBW = 1 kHz, expPow = 10 dBm, f = 1500 MHz				-100		dBc

Item No.	Description	Measurement to section	Min.	Actual	Max.	Measurement uncertainty	Unit
	RX average noise level RF1, RBW = 1 kHz, expPow = 10 dBm, f = 2200 MHz				-100		dBc
	RX average noise level RF1, RBW = 1 kHz, expPow = 10 dBm, f = 2700 MHz				-95		dBc
	RX average noise level RF2, RBW = 500 kHz, expPow = 33 dBm, f = 10 MHz				-73		dBc
	RX average noise level RF2, RBW = 500 kHz, expPow = 33 dBm, f = 500 MHz				-73		dBc
	RX average noise level RF2, RBW = 500 kHz, expPow = 33 dBm, f = 1000 MHz				-73		dBc
	RX average noise level RF2, RBW = 500 kHz, expPow = 33 dBm, f = 1500 MHz				-73		dBc
	RX average noise level RF2, RBW = 500 kHz, expPow = 33 dBm, f = 2200 MHz				-73		dBc
	RX average noise level RF2, RBW = 500 kHz, expPow = 33 dBm, f = 2700 MHz				-68		dBc
	RX average noise level RF2, RBW = 500 kHz, expPow = -4 dBm, f = 10 MHz				-73		dBc
	RX average noise level RF2, RBW = 500 kHz, expPow = -4 dBm, f = 500 MHz				-73		dBc
	RX average noise level RF2, RBW = 500 kHz, expPow = -4 dBm, f = 1000 MHz				-73		dBc
	RX average noise level RF2, RBW = 500 kHz, expPow = -4 dBm, f = 1500 MHz				-73		dBc
	RX average noise level RF2, RBW = 500 kHz, expPow = -4 dBm, f = 2200 MHz				-73		dBc
	RX average noise level RF2, RBW = 500 kHz, expPow = -4 dBm, f = 2700 MHz				-68		dBc
	RX average noise level RF4 IN, RBW = 1 kHz, expPow = -22 dBm, f = 10 MHz				-100		dBc
	RX average noise level RF4 IN, RBW = 1 kHz, expPow = 0 dBm, f = 500 MHz				-100		dBc
	RX average noise level RF4 IN, RBW = 1 kHz, expPow = 0 dBm, f = 1000 MHz				-100		dBc
	RX average noise level RF4 IN, RBW = 1 kHz, expPow = 0 dBm, f = 1500 MHz				-100		dBc

Item No.	Description	Measurement to section	Min.	Actual	Max.	Measurement uncertainty	Unit
	RX average noise level RF4 IN, RBW = 1 kHz, expPow = 0 dBm, f = 2200 MHz				-100		dBc
	RX average noise level RF4 IN, RBW = 1 kHz, expPow = 0 dBm, f = 2700 MHz				-95		dBc
	RX average noise level RF4 IN, RBW = 1 kHz, expPow = -22 dBm, f = 10 MHz				-100		dBc
	RX average noise level RF4 IN, RBW = 1 kHz, expPow = -22 dBm, f = 500 MHz				-100		dBc
	RX average noise level RF4 IN, RBW = 1 kHz, expPow = -22 dBm, f = 1000 MHz				-100		dBc
	RX average noise level RF4 IN, RBW = 1 kHz, expPow = -22 dBm, f = 1500 MHz				-100		dBc
	RX average noise level RF4 IN, RBW = 1 kHz, expPow = -22 dBm, f = 2200 MHz				-100		dBc
	RX average noise level RF4 IN, RBW = 1 kHz, expPow = -22 dBm, f = 2700 MHz				-95		dBc

TX Generator level error at RF1 (measurement on frequency cal. points)

Frequency MHz	10, 100, 200, 300, 400, 500, 600, 700, 800, 1000, 1100, 1200, 1300, 1400, 1500, 1600, 1700, , 2100, 2200, 2300, 2400, 2500, 2600, 2700	820, 840, 860, 880, 900, 920, 940, 960, 1710, 1730, 1750, 1770, 1790, 1810, 1830, 1850, 1870, 1890, 1910, 1930, 1950, 1970, 1990
Level in dBm	-33, -55, -73, -87, -106, -117, -130	-33, -55, -73, -87, -106, -117, -130
Tolerance	See data sheet: Base Unit RF Generator	See data sheet: GSM Specification RF Generator

TX Generator level error at RF2 (measurement on frequency cal. points)

Frequency MHz	10, 100, 200, 300, 400, 500, 600, 700, 800, 1000, 1100, 1200, 1300, 1400, 1500, 1600, 1700, , 2100, 2200, 2300, 2400, 2500, 2600, 2700	820, 840, 860, 880, 900, 920, 940, 960, 1710, 1730, 1750, 1770, 1790, 1810, 1830, 1850, 1870, 1890, 1910, 1930, 1950, 1970, 1990
Level in dBm	-16, -41, -59, -73, -95, -106, -117	-16, -41, -59, -73, -95, -106, -117
Tolerance	See data sheet: Base Unit RF Generator	See data sheet: GSM Specification RF Generator

TX Generator level error at RF3 OUT (measurement on frequency cal. points)

Frequency MHz	10, 100, 200, 300, 400, 500, 600, 700, 800, 1000, 1100, 1200, 1300, 1400, 1500, 1600, 1700, , 2100, 2200, 2300, 2400, 2500, 2600, 2700	820, 840, 860, 880, 900, 920, 940, 960, 1710, 1730, 1750, 1770, 1790, 1810, 1830, 1850, 1870, 1890, 1910, 1930, 1950, 1970, 1990
Level in dBm	+5, -18, -36, -50, -72, -80, -90	+5, -18, -36, -50, -72, -80, -90
Tolerance	See data sheet: Base Unit RF Generator	See data sheet: GSM Specification RF Generator

RX Power meter (frequency selective) level error at RF1 (measurement on frequency cal. points)

Frequency in MHz	50, 100, 200, 300, 400, 500, 600, 700, 800, 1000, 1100, 1200, 1300, 1400, 1500, 1600, 1700, , 2000, 2100, 2200, 2300, 2400, 2500, 2600, 2700	450, 470, 490, 820, 840, 860, 880, 900, 920, 940, 960, 1720, 1740, 1760, 1780, 1800, 1820, 1840, 1860, 1880, 1900, 1920, 1940, 1960, 1980
Level in dBm	+47, +40, +33, +30, +25, +20, +15, +10, +6, 0, -5, -10, -15, -20, -25, -30, -35, -40 Note: P = -40 dBm is valid for f = 50 MHz to 2200 MHz only	+47, +40, +33, +30, +25, +20, +15, +10, +6, 0, -5, -10, -15, -20, -25, -30, -35, -40 Note: P = -40 dBm is valid for f = 50 MHz to 2200 MHz only
Tolerance	See data sheet: Base Unit RF Analyzer	See data sheet: GSM Specification RF Analyzer

RX Power meter (frequency selective) level error at RF2 (measurement on frequency cal. points)

Frequency in MHz	50, 100, 200, 300, 400, 500, 600, 700, 800, 1000, 1100, 1200, 1300, 1400, 1500, 1600, 1700, , 2000, 2100, 2200, 2300, 2400, 2500, 2600, 2700	450, 470, 490, 820, 840, 860, 880, 900, 920, 940, 960, 1720, 1740, 1760, 1780, 1800, 1820, 1840, 1860, 1880, 1900, 1920, 1940, 1960, 1980
Level in dBm	+33, +26, +19, +16, +11, +6, +1, -4, -8, -14, -19, -24, -29, -34, -39, -44, -49, -54 Note: P = -54 dBm is valid for f = 50 MHz to 2200 MHz only	+33, +26, +19, +16, +11, +6, +1, -4, -8, -14, -19, -24, -29, -34, -39, -44, -49, -54 Note: P = -54 dBm is valid for f = 50 MHz to 2200 MHz only
Tolerance	See data sheet: Base Unit RF Analyzer	See data sheet: GSM Specification RF Analyzer

**RX Power meter (frequency selective) level error at RF4 IN
(measurement on frequency cal. points)**

Frequency in MHz	50, 100, 200, 300, 400, 500, 600, 700, 800, 1000, 1100, 1200, 1300, 1400, 1500, 1600, 1700, , 2000, 2100, 2200, 2300, 2400, 2500, 2600, 2700	450, 470, 490, 820, 840, 860, 880, 900, 920, 940, 960, 1720, 1740, 1760, 1780, 1800, 1820, 1840, 1860, 1880, 1900, 1920, 1940, 1960, 1980
Level in dBm	0, -6, -9, -14, -19, -24, -29, -33, -39, -44, -49, -54, -59, -64, -69, -74, -80 Note: P = -80 dBm is valid for f = 50 MHz to 2200 MHz only	0, -6, -9, -14, -19, -24, -29, -33, -39, -44, -49, -54, -59, -4, -69, -74, -80 Note: P = -80 dBm is valid for f = 50 MHz to 2200 MHz only
Tolerance	See data sheet: Base Unit RF Analyzer	See data sheet: GSM Specification RF Analyzer

RX Power meter (wideband) level error at RF1 (measurement on frequency cal. points)

Frequency in MHz	50, 100, 200, 300, 400, 500, 600, 700, 800, 1000, 1100, 1200, 1300, 1400, 1500, 1600, 1700, , 2000, 2100, 2200, 2300, 2400, 2500, 2600, 2700	450, 470, 490, 820, 840, 860, 880, 900, 920, 940, 960, 1720, 1740, 1760, 1780, 1800, 1820, 1840, 1860, 1880, 1900, 1920, 1940, 1960, 1980
Level in dBm	+47, +40, +33, +30, +25, +20, +15, +10 Note: P > +33 dBm is calibrated from 800 MHz to 2000 MHz only;	+47, +40, +33, +30, +25, +20, +15, +10 Note: P > +33 dBm is calibrated from 800 MHz to 2000 MHz only;
Tolerance	See data sheet: Base Unit RF Analyzer	See data sheet: Base Unit RF Analyzer

RX Power meter (wideband) level error at RF2 (measurement on frequency cal. points)

Frequency in MHz	50, 100, 200, 300, 400, 500, 600, 700, 800, 1000, 1100, 1200, 1300, 1400, 1500, 1600, 1700, , 2000, 2100, 2200, 2300, 2400, 2500, 2600, 2700	450, 470, 490, 820, 840, 860, 880, 900, 920, 940, 960, 1720, 1740, 1760, 1780, 1800, 1820, 1840, 1860, 1880, 1900, 1920, 1940, 1960, 1980
Level in dBm	+33, +26, +19, +16, +11, +6, +1, -4	+33, +26, +19, +16, +11, +6, +1, -4
Tolerance	See data sheet: Base Unit RF Analyzer	See data sheet: Base Unit RF Analyzer

RX Power meter (wideband) level error at RF4 IN (measurement on frequency cal. points)

Frequency in MHz	50, 100, 200, 300, 400, 500, 600, 700, 800, 1000, 1100, 1200, 1300, 1400, 1500, 1600, 1700, , 2000, 2100, 2200, 2300, 2400, 2500, 2600, 2700	450, 470, 490, 820, 840, 860, 880, 900, 920, 940, 960, 1720, 1740, 1760, 1780, 1800, 1820, 1840, 1860, 1880, 1900, 1920, 1940, 1960, 1980
Level in dBm	0, -6, -9, -14, -19, -24, -29	0, -6, -9, -14, -19, -24, -29
Tolerance	See data sheet: Base Unit RF Analyzer	See data sheet: Base Unit RF Analyzer

Options for R&S CMU200: R&S CMU-K20, K21, K22, K23, K24, TX Generator GSM Modulation

Output RF3 OUT, level 10 dBm, GSM Non Signaling
 Training Sequence GSM0, Bit Modulation PRBS, Transmission Burst

Item No.	Description	Measurement to section	Min.	Actual	Max.	Measurement uncertainty	Unit
K20	TX GSM phase error at 460 MHz, peak	GSM Modulation	-4		+4		°
K20	TX GSM phase error at 460 MHz, rms		-1		+1		°
K20	TX GSM frequency error at 460 MHz		-15		+15		Hz
K20	TX GSM phase error at 496 MHz, peak		-4		+4		°
K20	TX GSM phase error at 496 MHz, rms		-1		+1		°
K20	TX GSM frequency error at 496 MHz		-15		+15		Hz
K21	TX GSM phase error at 921 MHz, peak		-4		+4		°
K21	TX GSM phase error at 921 MHz, rms		-1		+1		°
K21	TX GSM frequency error at 921 MHz		-15		+15		Hz
K21	TX GSM phase error at 960 MHz, peak		-4		+4		°
K21	TX GSM phase error at 960 MHz, rms		-1		+1		°
K21	TX GSM frequency error at 960 MHz		-15		+15		Hz
K22	TX GSM phase error at 1805 MHz, peak		-4		+4		°
K22	TX GSM phase error at 1805 MHz, rms		-1		14		°
K22	TX GSM frequency error at 1805 MHz		-15		+15		Hz
K22	TX GSM phase error at 1880 MHz, peak		-4		+4		°
K22	TX GSM phase error at 1880 MHz, rms		-1		+1		°
K22	TX GSM frequency error at 1880 MHz		-15		+15		Hz
K23	TX GSM phase error at 1930 MHz, peak		-4		+4		°
K23	TX GSM phase error at 1930 MHz, rms		-1		+1		°
K23	TX GSM frequency error at 1930 MHz		-15		+15		Hz
K23	TX GSM phase error at 1990 MHz, peak		-4		+4		°

Item No.	Description	Measurement to section	Min.	Actual	Max.	Measurement uncertainty	Unit
K23	TX GSM phase error at 1990 MHz, rms		-1		+1		°
K23	TX GSM frequency error at 1990 MHz		-15		+15		Hz
K24	TX GSM phase error at 869 MHz, peak		-4		+4		°
K24	TX GSM phase error at 869 MHz, rms		-1		+1		°
K24	TX GSM frequency error at 869 MHz		-15		+15		Hz
K24	TX GSM phase error at 894 MHz, peak		-4		+4		°
K24	TX GSM phase error at 894 MHz, rms		-1		+1		°
K24	TX GSM frequency error at 894 MHz		-15		+15		Hz

Options for R&S CMU200: R&S CMU-K20, K21, K22, K23, K24, RX Analyzer GSM Demodulation

Input RF2, GSM Non Signaling

Training Sequence GSM0, Trigger Source IF Power, Trigger Level Medium

Item No.	Description	Measurement to section	Min.	Actual	Max.	Measurement uncertainty	Unit
K20	GSM phase error RX at 450 MHz, peak, level +5 dBm	RX Demodulation	-2		+2		°
K20	RX GSM phase error at 450 MHz, rms, level +5 dBm		-0.6		+0.6		°
K20	RX GSM frequency error at 450 MHz, level +5 dBm		-10		+10		Hz
K20	RX GSM phase error at 486 MHz, peak, level -14 dBm		-2		+2		°
K20	RX GSM phase error at 486 MHz, rms, level -14 dBm		-0.6		+0.6		°
K20	RX GSM frequency error at 486 MHz, level -14 dBm		-10		+10		Hz
K21	RX GSM phase error at 876 MHz, peak, level +5 dBm	RX Demodulation	-2		+2		°
K21	RX GSM phase error at 876 MHz, rms, level +5 dBm		-0.6		+0.6		°
K21	RX GSM frequency error at 876 MHz, level +5 dBm		-10		+10		Hz
K21	RX GSM phase error at 915 MHz, peak, level -14 dBm		-2		+2		°
K21	RX GSM phase error at 915 MHz, rms, level -14 dBm		-0.6		+0.6		°

Item No.	Description	Measurement to section	Min.	Actual	Max.	Measurement uncertainty	Unit
K21	RX GSM frequency error at 915 MHz, level -14 dBm		-10		+10		Hz
K22	RX GSM phase error at 1710 MHz, peak, level +5 dBm	RX Demodulation	-2		+2		°
K22	RX GSM phase error at 1710 MHz, rms, level +5 dBm		-0.6		+0.6		°
K22	RX GSM frequency error at 1710 MHz, level +5 dBm		-10		+10		Hz
K22	RX GSM phase error at 1785 MHz, peak, level -14 dBm		-2		+2		°
K22	RX GSM phase error at 1785 MHz, rms, level -14 dBm		-0.6		+0.6		°
K22	RX GSM frequency error at 1785 MHz, level -14 dBm		-10		+10		Hz
K23	RX GSM phase error at 1850 MHz, peak, level +5 dBm	RX Demodulation	-2		+2		°
K23	RX GSM phase error at 1850 MHz, rms, level +5 dBm		-0.6		+0.6		°
K23	RX GSM frequency error at 1850 MHz, level +5 dBm		-10		+10		Hz
K23	RX GSM phase error at 1910 MHz, peak, level -14 dBm		-2		+2		°
K23	RX GSM phase error at 1910 MHz, rms, level -14 dBm		-0.6		+0.6		°
K23	RX GSM frequency error at 1910 MHz, level -14 dBm		-10		+10		Hz
K24	RX GSM phase error at 824 MHz, peak, level +5 dBm	RX Demodulation	-2		+2		°
K24	RX GSM phase error at 824 MHz, rms, level +5 dBm		-0.6		+0.6		°
K24	RX GSM frequency error at 824 MHz, level +5 dBm		-10		+10		Hz
K24	RX GSM phase error at 849 MHz, peak, level -14 dBm		-2		+2		
K24	RX GSM phase error at 849 MHz, rms, level -14 dBm		-0.6		+0.6		
K24	RX GSM frequency error at 849 MHz, level -14 dBm		-10		+10		Hz

Options for R&S CMU200: R&S CMU-K83, K84, K85, K86, TX Generator CDMA2000 Modulation

Item No.	Description	Measurement to section	Min.	Actual	Max.	Measurement uncertainty	Unit
K83	TX CDMA2000 rho factor at 460 MHz	TX CDMA2000 Modulation	0.985				
K83	TX CDMA2000 carrier suppression at 460 MHz		35				dB
K83	TX CDMA2000 rho factor at 493.48 MHz	TX CDMA2000 Modulation	0.985				
K83	TX CDMA2000 carrier suppression at 493.48 MHz		35				dB
K84	TX CDMA2000 rho factor at 870.03 MHz	TX CDMA2000 Modulation	0.985				
K84	TX CDMA2000 carrier suppression at 870.03 MHz		35				dB
K84	TX CDMA2000 rho factor at 893.31 MHz	TX CDMA2000 Modulation	0.985				
K84	TX CDMA2000 carrier suppression at 893.31 MHz		35				dB
K85	TX CDMA2000 rho factor at 1930.05 MHz	TX CDMA2000 Modulation	0.985				
K85	TX CDMA2000 carrier suppression at 1930.05 MHz		35				dB
K85	TX CDMA2000 rho factor at 1989.95 MHz	TX CDMA2000 Modulation	0.985				
K85	TX CDMA2000 carrier suppression at 1989.95 MHz		35				dB
K86	TX CDMA2000 rho factor at 2110 MHz	TX CDMA2000 Modulation	0.985				
K86	TX CDMA2000 carrier suppression at 2110 MHz		35				dB
K86	TX CDMA2000 rho factor at 2169.95 MHz	TX CDMA2000 Modulation	0.985				
K86	TX CDMA2000 carrier suppression at 2169.95 MHz		35				dB

Options for R&S CMU200: R&S CMU-K83, K84, K85, K86, RX Analyzer CDMA2000 Demodulation

Item No.	Description	Measurement to section	Min.	Actual	Max.	Measurement uncertainty	Unit
K83	RX CDMA2000 waveform quality at 450 MHz	RX CDMA2000 Demodulation	0.9965				
K83	RX CDMA2000 frequency measurement error at 450 MHz	RX CDMA2000 Demodulation	-30		+30		Hz
K83	RX CDMA2000 waveform quality at 483.480 MHz	RX CDMA2000 Demodulation	0.9965				
K83	RX CDMA2000 frequency measurement error at 483.480 MHz	RX CDMA2000 Demodulation	-30		+30		Hz
K84	RX CDMA2000 waveform quality at 825.030 MHz	RX CDMA2000 Demodulation	0.9965				
K84	RX CDMA2000 frequency measurement error at 825.030 MHz	RX CDMA2000 Demodulation	-30		+30		Hz
K84	RX CDMA2000 waveform quality at 848.310 MHz	RX CDMA2000 Demodulation	0.9965				
K84	RX CDMA2000 frequency measurement error at 848.310 MHz	RX CDMA2000 Demodulation	-30		+30		Hz
K85	RX CDMA2000 waveform quality at 1850.05 MHz	RX CDMA2000 Demodulation	0.9965				
K85	RX CDMA2000 frequency measurement error at 1850.05 MHz	RX CDMA2000 Demodulation	-30		+30		Hz
K85	RX CDMA2000 waveform quality at 1909.950 MHz	RX CDMA2000 Demodulation	0.9965				
K85	RX CDMA2000 frequency measurement error at 1909.950 MHz	RX CDMA2000 Demodulation	-30		+30		Hz
K86	RX CDMA2000 waveform quality at 1920.00 MHz	RX CDMA2000 Demodulation	0.9965				
K86	RX CDMA2000 frequency measurement error at 1920.00 MHz	RX CDMA2000 Demodulation	-30		+30		Hz
K86	RX CDMA2000 waveform quality at 1979.950 MHz	RX CDMA2000 Demodulation	0.9965				
K86	RX CDMA2000 frequency measurement error at 1979.950 MHz	RX CDMA2000 Demodulation	-30		+30		Hz

Options for R&S CMU200: R&S CMU-K66, TX Generator WCDMA Modulation

Item No.	Description	Measurement to section	Min.	Actual	Max.	Measurement uncertainty	Unit
K66	TX WCDMA global EVM rms at 2110 MHz, level -46 dBm, RF2, 12.2kbps	TX WCDMA Modulation			8.0		%
K66	TX WCDMA global EVM rms at 2170 MHz, level -46dBm, RF2, 12.2kbps	TX WCDMA Modulation			8.0		%
K66	TX WCDMA global EVM rms at 2110 MHz, level -23 dBm, RF3OUT, 12.2kbps	TX WCDMA Modulation			8.0		%
K66	TX WCDMA global EVM rms at 2170 MHz, level -23 dBm, RF3OUT, 12.2kbps	TX WCDMA Modulation			8.0		%
K66	TX WCDMA global EVM rms at 2110 MHz, level -46 dBm, RF2, 384kbps	TX WCDMA Modulation			8.0		%
K66	TX WCDMA global EVM rms at 2170 MHz, level -46 dBm, RF2, 384kbps	TX WCDMA Modulation			8.0		%
K66	TX WCDMA global EVM rms at 2110 MHz, level -23 dBm, RF3OUT, 384kbps	TX WCDMA Modulation			8.0		%
K66	TX WCDMA global EVM rms at 2170 MHz, level -23 dBm, RF3OUT, 384kbps	TX WCDMA Modulation			8.0		%

Options for R&S CR&S MU200: R&S CMU-K65 RX Analyzer WCDMA Demodulation

Item No.	Description	Measurement to section	Min.	Actual	Max.	Measurement uncertainty	Unit
K65	RX WCDMA EVM rms at 1920 MHz, Max level +25dBm, input level +10dBm, RF 2	RX WCDMA Demodulation			2.5		%
K65	RX WCDMA I/Q Origin Offset at 1920 MHz, Max level +25 dBm, input level +10dBm, RF 2	RX WCDMA Demodulation			-55		dB
K65	RX WCDMA I/Q Imbalance at 1920 MHz, Max level +25 dBm, input level +10dBm, RF 2	RX WCDMA Demodulation			-30		dB
K65	RX WCDMA Carrier frequency error at 1920 MHz, Max level +25 dBm, input level +10dBm, RF 2	RX WCDMA Demodulation	-10		10		Hz
K65	RX WCDMA Peak code domain error at 1920 MHz, Max level +25 dBm, input level +10dBm, RF 2	RX WCDMA Demodulation			-40		dB
K65	RX WCDMA EVM rms at 1980 MHz, Max level +25 dBm, input level +10dBm, RF 2	RX WCDMA Demodulation			2.5		%
K65	RX WCDMA I/Q Origin Offset at 1980 MHz, Max level +25 dBm, input level +10dBm, RF 2	RX WCDMA Demodulation			-55		dB
K65	RX WCDMA I/Q Imbalance at 1980 MHz, Max level +25 dBm, input level +10dBm, RF 2	RX WCDMA Demodulation			-30		dB
K65	RX WCDMA Carrier frequency error at 1980 MHz, Max level +25 dBm, input level +10dBm, RF 2	RX WCDMA Demodulation	-10		10		Hz
K65	RX WCDMA Peak code domain error at 1980 MHz, Max level +25 dBm, input level +10dBm, RF 2	RX WCDMA Demodulation			-40		dB
K65	RX WCDMA EVM rms at 1920 MHz, Max level +25 dBm, input level +10dBm, RF 2	RX WCDMA Demodulation			2.5		%
K65	RX WCDMA I/Q Origin Offset at 1920 MHz, Max level +9 dBm, input level +5dBm, RF 2	RX WCDMA Demodulation			-55		dB
K65	RX WCDMA I/Q Imbalance at 1920 MHz, Max level +9 dBm, input level +5dBm, RF 2	RX WCDMA Demodulation			-30		dB
K65	RX WCDMA Carrier frequency error at 1920 MHz, Max level +9 dBm, input level +5dBm, RF 2	RX WCDMA Demodulation	-10		10		Hz
K65	RX WCDMA Peak code domain error at 1920 MHz, Max level +9 dBm, input level +5dBm, RF 2	RX WCDMA Demodulation			-40		dB

Item No.	Description	Measurement to section	Min.	Actual	Max.	Measurement uncertainty	Unit
K65	RX WCDMA EVM rms at 1980 MHz, Max level +25dBm, input level +10dBm, RF 2	RX WCDMA Demodulation			2.5		%
K65	RX WCDMA I/Q Origin Offset at 1980 MHz, Max level +9dBm, input level +5dBm, RF 2	RX WCDMA Demodulation			-55		dB
K65	RX WCDMA I/Q Imbalance at 1980 MHz, Max level +9dBm, input level +5dBm, RF 2	RX WCDMA Demodulation			-30		dB
K65	RX WCDMA Carrier frequency error at 1980 MHz, Max level +9dBm, input level +5dBm, RF 2	RX WCDMA Demodulation	-10		10		Hz
K65	RX WCDMA Peak code domain error at 1980 MHz, Max level +9dBm, input level +5dBm, RF 2	RX WCDMA Demodulation			-40		dB
K65	RX WCDMA EVM rms at 1920 MHz, Max level +25dBm, input level +10dBm, RF 2	RX WCDMA Demodulation			2.5		%
K65	RX WCDMA I/Q Origin Offset at 1920 MHz, Max level -14dBm, input level -20dBm, RF 2	RX WCDMA Demodulation			-55		dB
K65	RX WCDMA I/Q Imbalance at 1920 MHz, Max level -14dBm, input level -20dBm, RF 2	RX WCDMA Demodulation			-30		dB
K65	RX WCDMA Carrier frequency error at 1920 MHz, Max level -14dBm, input level -20dBm, RF 2	RX WCDMA Demodulation	-10		10		Hz
K65	RX WCDMA Peak code domain error at 1920 MHz, Max level -14dBm, input level -20dBm, RF 2	RX WCDMA Demodulation			-40		dB
K65	RX WCDMA EVM rms at 1980 MHz, Max level +25dBm, input level +10dBm, RF 2	RX WCDMA Demodulation			2.5		%
K65	RX WCDMA I/Q Origin Offset at 1980 MHz, Max level -14dBm, input level -20dBm, RF 2	RX WCDMA Demodulation			-55		dB
K65	RX WCDMA I/Q Imbalance at 1980 MHz, Max level -14dBm, input level -20dBm, RF 2	RX WCDMA Demodulation			-30		dB
K65	RX WCDMA Carrier frequency error at 1980 MHz, Max level -14dBm, input level -20dBm, RF 2	RX WCDMA Demodulation	-10		10		Hz
K65	RX WCDMA Peak code domain error at 1980 MHz, Max level -14dBm, input level -20dBm, RF 2	RX WCDMA Demodulation			-40		dB
K65	RX WCDMA EVM rms at 1920 MHz, Max level 0dBm, input level -5dBm, RF 4 IN	RX WCDMA Demodulation			2.5		%

Item No.	Description	Measurement to section	Min.	Actual	Max.	Measurement uncertainty	Unit
K65	RX WCDMA I/Q Origin Offset at 1920 MHz, Max level 0dBm, input level -5 dBm, RF 4 IN	RX WCDMA Demodulation			-55		dB
K65	RX WCDMA I/Q Imbalance at 1920 MHz, Max level 0dBm, input level -5 dBm, RF 4 IN	RX WCDMA Demodulation			-30		dB
K65	RX WCDMA Carrier frequency error at 1920 MHz, Max level 0dBm, input level -5 dBm, RF 4 IN	RX WCDMA Demodulation	-10		10		Hz
K65	RX WCDMA Peak code domain error at 1920 MHz, Max level 0dBm, input level -5 dBm, RF 4 IN	RX WCDMA Demodulation			-40		dB
K65	RX WCDMA EVM rms at 1980 MHz, Max level 0dBm, input level -5 dBm, RF 4 IN	RX WCDMA Demodulation			2.5		%
K65	RX WCDMA I/Q Origin Offset at 1980 MHz, Max level 0dBm, input level -5 dBm, RF 4 IN	RX WCDMA Demodulation			-55		dB
K65	RX WCDMA I/Q Imbalance at 1980 MHz, Max level 0dBm, input level -5 dBm, RF 4 IN	RX WCDMA Demodulation			-30		dB
K65	RX WCDMA Carrier frequency error at 1980 MHz, Max level 0dBm, input level -5 dBm, RF 4 IN	RX WCDMA Demodulation	-10		10		Hz
K65	RX WCDMA Peak code domain error at 1980 MHz, Max level 0dBm, input level -5 dBm, RF 4 IN	RX WCDMA Demodulation			-40		dB
K65	RX WCDMA EVM rms at 1920 MHz, Max level -37dBm, input level -50 dBm, RF 4 IN	RX WCDMA Demodulation			2.5		%
K65	RX WCDMA I/Q Origin Offset at 1920 MHz, Max level -37dBm, input level -50 dBm, RF 4 IN	RX WCDMA Demodulation			-55		dB
K65	RX WCDMA I/Q Imbalance at 1920 MHz, Max level -37dBm, input level -50 dBm, RF 4 IN	RX WCDMA Demodulation			-30		dB
K65	RX WCDMA Carrier frequency error at 1920 MHz, Max level -37dBm, input level -50 dBm, RF 4 IN	RX WCDMA Demodulation	-10		10		Hz
K65	RX WCDMA Peak code domain error at 1920 MHz, Max level -37dBm, input level -50 dBm, RF 4 IN	RX WCDMA Demodulation			-40		dB
K65	RX WCDMA EVM rms at 1980 MHz, Max level -37dBm, input level -50 dBm, RF 4 IN	RX WCDMA Demodulation			2.5		%
K65	RX WCDMA I/Q Origin Offset at 1980 MHz, Max level -37dBm, input level -50 dBm, RF 4 IN	RX WCDMA Demodulation			-55		dB

Item No.	Description	Measurement to section	Min.	Actual	Max.	Measurement uncertainty	Unit
K65	RX WCDMA I/Q Imbalance at 1980 MHz, Max level -37dBm, input level -50dBm, RF 4 IN	RX WCDMA Demodulation			-30		dB
K65	RX WCDMA Carrier frequency error at 1980 MHz, Max level -37dBm, input level -50dBm, RF 4 IN	RX WCDMA Demodulation	-10		10		Hz
K65	RX WCDMA Peak code domain error at 1980 MHz, Max level -37dBm, input level -50 dBm, RF 4 IN	RX WCDMA Demodulation			-40		dB

2 Adjustment

The following chapter describes the manual adjustment of the reference sources as well as the software-controlled adjustment of individual module data after module replacement (automatic adjustment of module data).

The manual adjustment of the +5 VDC reference source which provides the highly stable DC reference voltage for the individual R&S CMU modules as well as that of the 10 MHz reference frequency source which determines the frequency accuracy of the R&S CMU are described. The adjustment permits to maintain and restore the data integrity of the instrument.

Manual adjustments must be performed at an ambient temperature between +23°C and +26°C after the instrument has warmed up.

After the software-controlled adjustment has been performed, the R&S CMU is ready for use and offers full data integrity except for the level accuracy. In order to attain the level accuracy specified in the data sheet, it is necessary to record the path error data. To this end, the R&S CMU must be tested using the test system ACS 100 (see chapter 1, *Performance Test*).

Manual Adjustment

In the following, the measuring instruments and auxiliary means required for the manual adjustment of the R&S CMU, the appropriate preparations of the instrument as well as the individual adjustments will be explained.

Measuring Instruments and Auxiliary Equipment

Table 2-1 Measuring instruments and auxiliary equipment for manual adjustment of the R&S CMU

Item	Type of instrument	Required characteristics	Appropriate device	R & S order number	Use page
1	Voltmeter	DC measurement	R&S URE3	350.5315.03	
2	Spectrum analyzer with frequency counter	Frequency measurement up to 1 GHz	R&S FSE	1066.3010.20 (30)	

Preparing the Instrument

- Opening the casing:
- Remove the power plug on the R&S CMU and place the R&S CMU onto the front handles.
 - Loosen the four Phillips screws at the four rear-panel feet and take off the feet.
 - Pull off the instrument tube towards the top.
 - Locate the adjustment devices (see chapter 5, drawing 1100.0008.01 D page 3).
 - After performing the manual adjustment, close the casing again in the reverse order.

Note: *If only the Option OCXO REFERENCE OSC. R&S CMU -B11/B12 is to be adjusted, it is not necessary to open the complete tube of the R&S CMU. The adjustment can be made from outside through the ventilation holes using a small screwdriver (see chapter 5, drawing 1100.0008.01 D page 3).*

Adjusting the + 5 VDC Reference Voltage

- Preparation:
- Connect the DC voltmeter test cable to the SMB plug X221 (see chapter 5, drawing 1100.1027.01 page 1) on the motherboard.
 - Switch on the R&S CMU and allow it to warm up for approx. 5 minutes.
- Adjustment:
- Use potentiometer R120 on the REFERENCE BOARD to adjust the measured value at the DC voltmeter to + 5.000 V ± 1 mV.

Adjusting the 10 MHz Reference Frequency

Preparation: The measurement can be performed either at connector REF OUT1 (rear of R&S CMU) at 10 MHz or at connector RF3 OUT (front) at 1 GHz using a frequency counter.

- For the measurement at connector RF3 OUT set the generator to 1 GHz and 13 dBm without modulation in the RF menu.

For the adjustment, the R&S CMU must be set to internal reference source.

- This setting is to be selected in the *Connection Control – Sync.* menu of the respective application.

Note: *The measurement at 1 GHz can be performed with a lower frequency counter resolution (1 Hz) in order to achieve a faster adjustment.*

TCXO

Adjustment: ➤ Use potentiometer R121 on the REFERENCE BOARD to adjust the measured value at the frequency counter to
10.000 000 0 MHz \pm 0.5 Hz (at REF OUT1) or
1.000 000 000 GHz \pm 50 Hz (at RF3 OUT).

Note: *This adjustment is only required if none of the options R&S CMU - B11 or B12 is installed.*

OCXO REFERENCE OSC. R&S CMU -B11

(if option is installed)

Adjustment: ➤ Use potentiometer R5 on the OCXO REFERENCE OSC. BOARD to adjust the measured value at the frequency counter to
10.000 000 00 MHz $-0.1/ +0.05$ Hz (at REF OUT1) or
1.000 000 000 GHz -10 Hz/ $+5$ Hz (at RF3 OUT)
(a lead of at least -2 to -5 Hz at 1 GHz is desired because of aging).

Note: *The R&S CMU must have been switched on for at least 5 minutes so that the OCXO has warmed up.*

OCXO REFERENCE OSC. R&S CMU -B12

(if the option is installed)

Adjustment: ➤ Use potentiometer R5 on the OCXO REFERENCE OSC. BOARD to adjust the measured value at the frequency counter to
10.000 000 00 MHz $-0.1/ +0.05$ Hz or (at REFOUT1) or
1.000 000 000 GHz -10 Hz/ $+5$ Hz (at RF3OUT)
(a lead of at least -2 to -5 Hz at 1 GHz is desired because of aging).

Notes: *The R&S CMU must have been switched on for at least 10 minutes so that the OCXO has warmed up.
During the adjustment, operate the R&S CMU in the horizontal position!*

Automatic Adjustment of Module Data

In order to match the data stored in EEPROMs on the respective modules to the complete instrument, an automatic adjustment of module data is always necessary after replacing a module.

In addition to some standard information such as module name, serial number, hardware status and date of manufacture, these stored data items contain important pieces of information within value tables from module pre-testing, e.g. frequency responses for module error data.

This information permits to make the complete instrument ready for operation again (see also chapter 1, *Performance Test*).

In the following, the preparations and the procedure of the automatic module data adjustment will be explained.

Preparing the adjustment

- Replacement of module(s):
- Replace the faulty module(s) (see chapter 3, *module replacement*).
 - Close the R&S CMU casing (see chapter 3, *module replacement*).
 - Connect the R&S CMU to the mains and switch on.

Performing the adjustment

- Starting the version manager:
- Note the startup in the display when switching on the R&S CMU for the first time.
 - When a beep can be heard three times, press the *MENU SELECT* key.

The version manager is started (see also chapter 4, *Firmware Update*). The display includes the menu item *FIRMWARE UPDATE AFTER BOARD CHANGE*.

- Procedure:
- Press the softkey to the left of the above mentioned menu item.

The automatic adjustment of module data is started under software control.

It may take a few minutes to additionally perform firmware updates for microprocessors and programmable devices.

After the adjustment has been terminated, press the softkey to the left of the *EXIT* menu item, the operating software starts and the R&S CMU is ready for use and can be operated in the usual way.

3 Repair

This chapter describes the design of the R&S CMU, simple measures for repair and troubleshooting and, in particular, the replacement of modules. For troubleshooting and diagnosis, a maintenance menu is available, which permits to poll diagnostic voltages of the modules and indicate limit violations.

The installation of options and software update are explained in chapter 4 of this service manual.

Instrument Design and Function Description

Instrument design

For a detailed overview of the R&S CMU design refer to the block diagram below and the exploded views in chapter 5).

The following function description of the instrument refers to the block diagram.

Cabinet design

The casing of the R&S CMU is a robust, gray-blue Rohde & Schwarz standard casing according to BW 2000.

It consists of a frame with integrated rear panel and a labeling panel at the front. The frame is covered by a one-piece tube and screwed with four rear-panel feet. Two front handles are screwed to the frame as standard, an additional handle on the left side is deliverable as an accessory.

The dimensions are as follows:

Overall: W x H x L 465.1 mm x 196.5 mm x 517 mm

Rackmount: 19" 1/1, 4HU, 450

Note: *The terms "left" and "right" in the manual always refer to the front view of the instrument.*

Block diagram

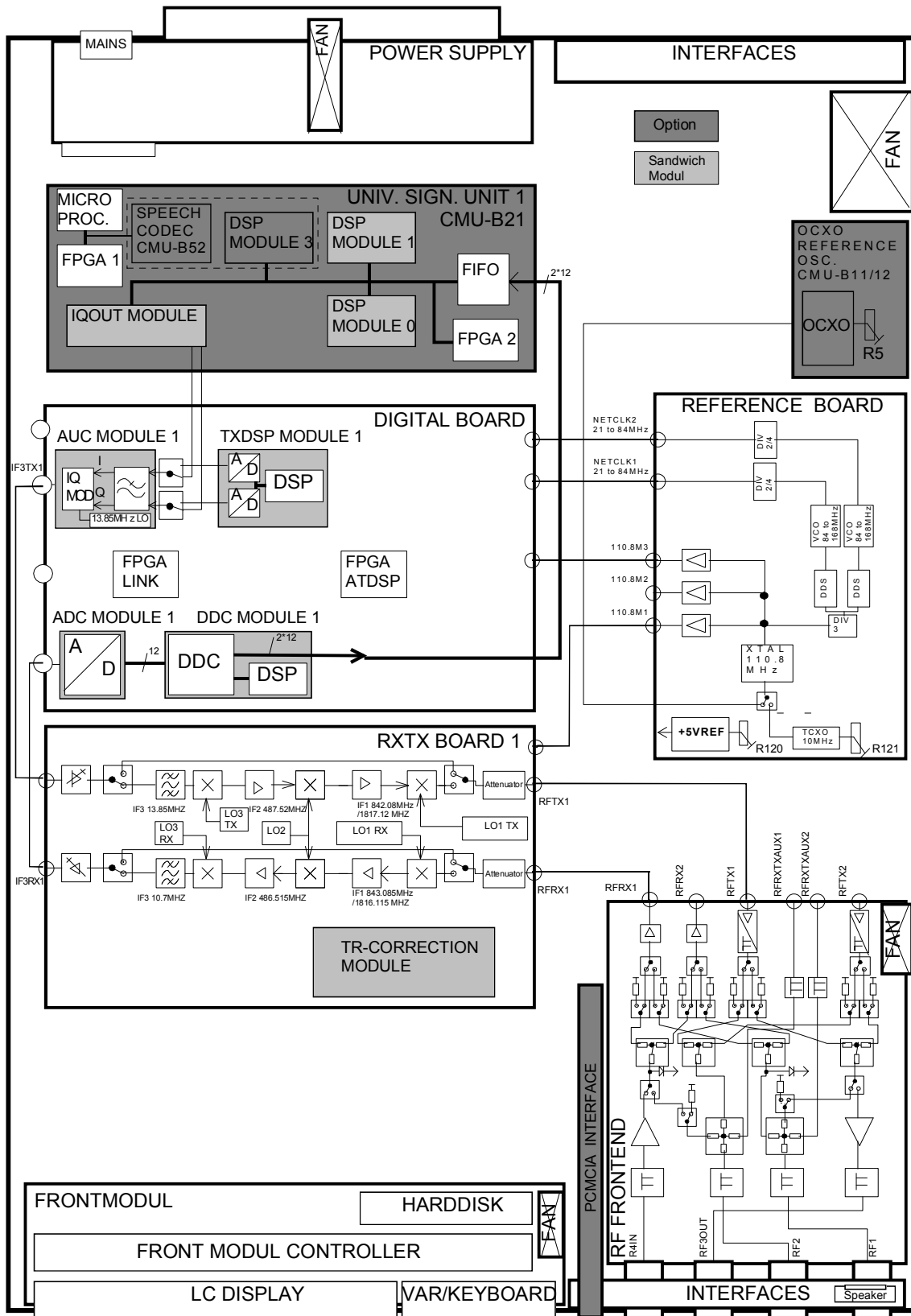

Instrument Frame

The instrument frame consists of front frame, module support, partition, cage and air duct. The module support is screwed to the front frame. It incorporates the partition, the cage and the air duct and provides all mechanical connectors and slots for modules. The MOTHERBOARD for electrical connection of the modules as well as the big fan for cooling the modules are screwed to the instrument frame.

Rear of Instrument Frame

At the rear of the R&S CMU instrument frame, the power supply with integrated power plug and switch as well as other important electrical interfaces are fitted (see chapter 1, *operating manual*).

The power supply unit can be easily replaced.

A further rear panel that is screwed to the frame serves as support for further electrical interfaces and optional extensions.

Front of Instrument Frame

The front of the instrument frame incorporates the FRONT MODULE, the most important electrical interfaces as well as the optional FLOPPY DISK or PCMCIA INTERFACE drive.

FRONT MODULE

The components of the FRONT MODULE that are directly arranged at the front of the R&S CMU are the LCD and the operating keys with the spinwheel.

The operating keys consist of a membrane and a mat inserted into the keyboard frame of the FRONT MODULE. The operating keys are colored differently to highlight their function and partly labeled.

This module can be conveniently replaced as a unit.

The beeper with sound outlet on the FRONT MODULE is used for acoustic prompts and error warnings.

Electrical interfaces

The electrical interfaces are mounted on an extra mounting plate. The RF interfaces are components of the RF FRONTEND.

Loudspeaker

A loudspeaker with sound outlets at the labeling panel allows for acoustic hints for AF signals. It is controlled via the option R&S CMU-B41 AUDIO-GEN. + ANA.

Cooling the Instrument

Axial fan in the casing The right side panel contains a temperature-controlled axial fan (120 mm x 120 mm x 38 mm), which sucks in cold ambient air at the right tube of the casing and blows it through the modules via a ventilation duct and further ventilation slots. The amount of air is controlled via the width of the slots depending on the power dissipation of the module. The modules are cooled by the air flow, and the heated air is then blown out at the left side panel.

Axial fan of power supply In addition, the power supply of the R&S CMU is equipped with its own temperature-controlled axial fan (80 mm x 80 mm x 25 mm) with a separate air circulation. The fan sucks in cold air on the left rear side of the power supply casing and blows out the heat produced in the power supply on the right rear side of the power supply casing.

Axial fan of FRONT MODULE For cooling the controller board, the FRONT MODULE is provided with its own axial fan (40 mm x 40 mm x 10 mm), which sucks in cold ambient air on the left side of the instrument and blows it out at the right side panel.

Axial fan of RF FRONTEND The RF FRONTEND which can process powers up to 50 W is equipped with an aluminum casing with its own air duct, cooling fins and a temperature-controlled axial fan (40 mm x 40 mm x 20 mm), which dissipates the heat by sucking in cold air directly on the right rear side of the instrument and blowing in out again on the right front side of the instrument.

The cooling concept makes sure that all components are optimally cooled so that the complete instrument achieves a high MTBF.

FRONT MODULE

The FRONT MODULE consists of an aluminum case panel and a mounting plate which accommodates the LCD, the keyboard mat with the membrane and the spinwheel.

The case panel incorporates the FRONT MODULE CONTROLLER, the fan and the hard disk.

LCD The color LCD provides a visible output of any information, measurements etc. to the user.

The resolution of the LCD is 640 * 480 pixels (VGA).

The display incorporates two cold cathode tubes for the illumination. The high voltage required for this purpose is generated in an extra DC/AC converter mounted next to the display on the mounting plate and connected both to the display and the controller board via a cable.

The liquid crystal display is controlled via a ribbon cable that is plugged in on the controller board.

Operating keys The operating keys consisting of a keyboard mat and a membrane release a contact when the rubber key is pressed. Two LEDs for the STANDBY/ON key (orange for STANDBY/green for ON) are also accommodated on this membrane.

The rubber keys enable the user to call up all R&S CMU functions.

The key evaluation and LED control are effected via a film cable connector on the controller board. Like the control of the two LEDs, it is controlled in a special microprocessor on the controller board by means of a matrix technique. This microprocessor permits to store the status of the STANDBY/ON key when switching off using the power switch.

Spinwheel The spinwheel consists of a flexible magnetic ring with individual magnets for the lock-in positions. With each turn of the spinwheel, electrical pulses are released from the LEDs and the optical position detectors and sent via a ribbon cable to the microprocessor on the FRONT MODULE CONTROLLER for evaluation.

The spinwheel serves the user as a further means of data entry and operation.

FRONT MODULE CONTROLLER The FRONT MODULE CONTROLLER contains all the necessary components on a board such as processor, memory chips, I/O devices (ISA bus), lithium battery, IEC-bus controller (IEEE), two serial interfaces (COM1/2), a parallel interface (LPT), LCD graphics controller, external VGA monitor graphics interface (monitor) and an external keyboard connection (keyboard PS/2).

In addition, a floppy controller for an external floppy disk drive and an IDE hard disk controller are integrated on the controller board.

Hard disk The hard disk is screwed to the printed circuit board above the FRONT MODULE CONTROLLER (MODEL 04) or is screwed to the rear of the aluminum case panel (MODEL 12) and connected to the printed circuit board via a ribbon cable.

Fan A small axial fan in the case panel produces an air flow through the FRONT MODULE CONTROLLER, cooling it with cold ambient air.

Connection The FRONT MODULE is directly plugged to the MOTHERBOARD via two 96-pin FUTURE BUS connectors (MODEL 04) and one additional 110-pin PCI Bus connector (MODEL 12).

POWER SUPPLY

The POWER SUPPLY of the R&S CMU consists of a two-part aluminum casing with three boards arranged in a so-called sandwich technique (U-shape). In addition to cooling, the axial fan already mentioned above (see cooling of instrument) is also used to support the three boards.

STANDBY/ON signal The control signal STANDBY/ON controlled by the FRONT MODULE CONTROLLER (depending on the operating key STANDBY/ON on the front of the instrument frame) activates the power supply.

Power Factor Correction (PFC) and Standby circuit The POWER SUPPLY is a primary clocked switching power supply with Power Factor Correction (PFC) and Standby circuit (+12 V Standby). On the secondary side, it generates all DC voltages (+3.3 V; +5.2 V; +6 V; +8 V; +12 V; +12 VFAN; +12 V Standby; +28 V; -12 V) for the R&S CMU. The secondary voltages are open-circuit-proof and short-circuit-proof with respect to ground and each other.

POWERGOOD - Signal When switching on and off (defined reset), the POWER SUPPLY generates a POWERGOOD signal for control of the FRONT MODULE CONTROLLER.

Overtemperature protection An overtemperature protective circuit is additionally installed to prevent overheating. This status is taken to the FRONT MODULE CONTROLLER via a status signal (OT).

AC voltage supply A 3-pin connector with integrated 2-pin mains switch for connection with the AC-Supply is installed on the rear panel of the POWER SUPPLY. From there, the AC supply voltage is internally taken to the first board via two cables. Two fuses are also fitted there as a means of fire protection.

Note: *These fuses are not accessible to the user from outside and are only blown in the case of a serious fault of the power supply (servicing required!).*

Primary side The following circuit parts follow on the first board: EMI filter and power rectifier. The rectified AC supply voltage is taken via a cable to the second board of the Power Factor Correction (PFC). This circuit converts the rectified AC supply voltage up to a constant voltage of 380 VDC. Then this voltage is taken to a step down converter which provides a constant voltage of 280 VDC for the subsequent resonance step down converter, which chops it with approx. 35 kHz. An additional connecting cable is used to feed the big transformer located on the first board. It is provided with taps for the various secondary voltages, and the following rectifiers constitute the transition to the DC secondary side.

Secondary side The +12 V-, -12 V- and +6 V- secondary voltages are provided with analog regulators in order to ensure a high spurious suppression. The +3.3 V- and +5.2 V- secondary voltages have their own stepdown converters to achieve small power dissipations. The +28 V- voltage requires a stepup converter in order to generate the high voltage with a high accuracy. At the +12 VFAN, a constant current source is used for efficient suppression of fan interference. The secondary voltages are then filtered and subsequently taken to the output connector.

Standby converter and control unit

The third printed circuit board which serves as a connection between the first and second board accommodates the control and monitoring circuit parts. Besides, it includes the standby converter, which generates a +12-V standby voltage from the 380 VDC voltage of the PFC circuit.

Connection

The POWER SUPPLY is directly connected to the MOTHERBOARD via a 96-pin FUTURE-bus connector on the MOTHERBOARD and screwed to the integrated rear panel of the R&S CMU with its casing. At model SN250 (1091.1982.00) an additional 4-pin power connector is available for connection of the option R&S CMU-B66/68 .

MOTHERBOARD

The MOTHERBOARD (1100.0908) consists of five individual printed circuit boards: MOTHERBOARD1, MOTHERBOARD2, FRONTPANEL BOARD, REARPANEL BOARD1 and REARPANEL BOARD2.

MOTHERBOARD1

The MOTHERBOARD1 is the central motherboard and serves as connection between most of the modules. It supplies the modules both with voltages and control, status and bus signals in various layers (12-layer multilayer).

The MOTHERBOARD1 accommodates various ISA bus driver devices for the PCMCIA INTERFACE control as well as protective circuits. These protective circuits consist of diodes and polyswitches (current-dependent, self-opening and closing fuses) and protect against external overvoltages of the interface signals.

Nine LEDs indicate the status of the supply voltages and help with troubleshooting.

On MOTHERBOARD1, a circuit for temperature-dependent instrument fan control is also implemented:

The individual module temperatures are polled by the FRONT MODULE CONTROLLER of the R&S CMU. This information is passed on via the DIGITAL BOARD to the fan control with the aid of a control signal. The instrument fan is controlled such that an optimum module temperature is achieved on the one hand and as little noise as possible is emitted by the fan on the other hand.

MOTHERBOARD2

The MOTHERBOARD2 serves for supply and connection of the modules located higher at the side, the REFERENCE BOARD and a further option.

For connection with MOTHERBOARD1 two 50-pin ribbon cables are used.

FRONTPANEL BOARD

The FRONTPANEL BOARD is located at the front of the instrument frame and accommodates the external interfaces DATA1, DATA2, AUX3 and SPEECH. Besides, the six LEDs for the display of the active RF inputs/outputs are located there.

For connection with MOTHERBOARD1 a 50-pin ribbon cable is used.

REARPANEL BOARD1

The REARPANEL BOARD1 is screwed to the integrated rear panel of the R&S CMU below the POWER SUPPLY and accommodates the external interfaces IEEE, LPT, COM1, COM2, monitor and keyboard.

For connection with MOTHERBOARD1 two 34-pin ribbon cables are used.

REARPANEL BOARD2 The REARPANEL BOARD2 is mounted to the right of the integrated and unscrewable rear panel plate and accommodates the interfaces SERVICE, AUX, AUX4 as well as further spare interfaces. For connection with MOTHERBOARD1 two 34-pin ribbon cables are used.

The MOTHERBOARD (1100.2352) consists of four individual printed circuit boards: MOTHERBOARD1, MOTHERBOARD2, FRONTPANEL BOARD and REARPANEL BOARD2.

MOTHERBOARD1 The MOTHERBOARD1 is the central motherboard and serves as connection between most of the modules. It supplies the modules both with voltages and control, status and bus signals in various layers (12-layer multilayer). The MOTHERBOARD1 accommodates various ISA bus driver devices for the PCMCIA INTERFACE control as well as protective circuits. These protective circuits consist of diodes and polyswitches (current-dependent, self-opening and closing fuses) and protect against external overvoltages of the interface signals. MOTHERBOARD1 includes the external interfaces IEEE, LPT, COM1, COM2, monitor and keyboard. Nine LEDs indicate the status of the supply voltages and help with troubleshooting. On MOTHERBOARD1, a circuit for temperature-dependent instrument fan control is also implemented: The individual module temperatures are polled by the FRONT MODULE CONTROLLER of the R&S CMU. This information is passed on via the DIGITAL BOARD to the fan control with the aid of a control signal. The instrument fan is controlled such that an optimum module temperature is achieved on the one hand and as little noise as possible is emitted by the fan on the other hand.

MOTHERBOARD2 The MOTHERBOARD2 serves for supply and connection of the modules located higher at the side, the REFERENCE BOARD and a further option. For connection with MOTHERBOARD1 two 50-pin ribbon cables are used.

FRONTPANEL BOARD The FRONTPANEL BOARD is located at the front of the instrument frame and accommodates the external interfaces DATA1, DATA2, AUX3 and SPEECH. Besides, the six LEDs for the display of the active RF inputs/outputs are located there. For connection with MOTHERBOARD1 a 50-pin ribbon cable is used.

REARPANEL BOARD2 The REARPANEL BOARD2 is mounted to the right of the integrated and unscrewable rear panel plate and accommodates the interfaces SERVICE, AUX, AUX4 as well as further spare interfaces. For connection with MOTHERBOARD1 two 34-pin ribbon cables are used.

REFERENCE BOARD

The REFERENCE BOARD provides all required clock signals (NETCLK1/2) and reference frequencies (110.8 MHz) as well as the +5 VDC reference voltage for the R&S CMU. The REFERENCE BOARD is a plug-in module in HVC design.

Design At the top of the module, nine MMCX connectors are attached, which serve as inputs or outputs for various clock signals and are routed to the respective modules or the integrated rear panel with appropriate coax cables.

Two holes in the HVC panel at the top are used for adjusting the +5 VDC reference voltage and the 10 MHz TCXO reference frequency.

Connection The plug-in module REFERENCE BOARD is inserted in the R&S CMU on the right side on MOTHERBOARD2 using a 48-pin FUTURE-bus connector.

REFERENCE frequency generation All frequencies provided by the R&S CMU are derived from internal high-precision 10-MHz reference elements (TCXO or optional OCXO) or from externally applied frequencies.

A 110.8-MHz crystal oscillator is coupled in locked phase relation in a PLL loop with the selected reference.

The reference element TCXO is used as standard on the reference board. If the option OCXO (R&S CMU-B11 or -B12) is installed in the R&S CMU, it is automatically used as reference element and the standard TCXO is switched off.

It is additionally possible to switch over to external synchronization (see *Connection Control – Synch.* in Chapter 4 of the R&S CMU operating manual) and use the signal fed in at the BNC connector REF IN at the rear of the R&S CMU as reference signal.

At the BNC connector REF OUT1 at the rear of the R&S CMU, either the internal 10-MHz reference frequency or the signal applied at REF IN can be buffered and tapped depending on the selected reference element.

The 110.8-MHz sinewave signal of the crystal oscillator passes a harmonics filter, is buffered and provided at three MMXC connectors, serving as reference frequency for the RXTX BOARD1/2 and the DIGITAL BOARD.

At a further MMCX connector, the TTL signal RESFREQ is available with 27.7 MHz (110.8 MHz / 4) for the option R&S CMU-B41, *Audio Generator and Analyzer*, as clock signal.

Netclock generation The REFERENCE BOARD is also used for netclock generation, providing adjustable TTL clock frequencies from 21 MHz to 84 MHz with a very high frequency resolution of 0.1 Hz. This function is provided twice so that two independent netclock frequencies are available at the same time.

The signal generated by the 110.8-MHz crystal oscillator is divided by three and applied to a DDS (Direct Digital Synthesis) circuit. The DDS circuit is used as a fine-adjustable frequency divider and generates a divided signal between 9 MHz and 12 MHz.

This signal is then used in a further PLL as nominal value for the phase detector in order to tune a VCO (Voltage Controlled Oscillator) with a tuning range of 84 MHz to 168 MHz in locked phase relation.

A fractional divider used in the feedback of the PLL provides the actual value for the phase detector.

The output signal of the VCO is divided by two or four, buffered and provided at the MMCX connector NETCLK 1 or NETCLK 2 and serves as network-specific TTL clock for the DIGITAL BOARD.

Option OCXO REFERENCE OSC. R&S CMU-B11 or B12

This option consists of a printed circuit board with the reference element OCXO (oven-controlled crystal oscillator), the control circuit and a potentiometer for adjusting the OCXO.

Installation The option OCXO REFERENCE OSC. is installed on the right side below the instrument fan such that the potentiometer is easily accessible from outside without the need for opening the R&S CMU tube.

Connection The option OCXO is directly inserted via a 10-pin connector on the MOTHERBOARD and screwed to the module support by means of three screws.

The options R&S CMU-B11 and B12 are basically of the same design. The two options only differ from each other in the technical data of the OCXO such as aging and frequency drift.

RF FRONTEND

Design The printed circuit board of the RF FRONTEND is installed in a silver-coated aluminum casing which is screwed to the instrument frame. The RF FRONTEND is fitted at the right front of the R&S CMU such that the four RF N-type connectors which are directly connected to the FRONTEND board are accessible on the front of the instrument frame of the R&S CMU. This is absolutely necessary to ensure a good VSWR (Voltage Standing Wave Ratio).

Cooling system The aluminum casing in which the RF FRONTEND is installed is equipped with cooling fins in a special cooling duct and an extra temperature-controlled fan for heat dissipation if high RX power is fed in.

Control and supply Control and supply of the RF FRONTEND are effected from MOTHERBOARD1 via a 34-pin ribbon cable.

RF connectors For the internal RF connection to the RXTX BOARD1 (RFRX1, RFTX1) two SMA screw connections and coaxial solid-jacket cables are used. Thus a high-quality RF connection is ensured. Besides, two further internal RF connections (RFRX2, RFTX2) to the optional RXTX BOARD2 are available.

Two bidirectional monitor inputs/outputs (RFRXTXAUX1/2) at the RF FRONTEND permit to connect further RF devices via optional cables leading to the integrated rear panel of the R&S CMU.

As external RF interface, the RF FRONTEND is equipped with the four N-type connectors RF1, RF2, RF3OUT, RF4IN, which permit to perform all the RF measurements of the R&S CMU.

RF1 and RF2 are bidirectional inputs/outputs depending on the setting and measurement application.

RF3OUT is a unidirectional output.

RF4IN is a unidirectional input.

Optical indication For optical indication of the selected N-connectors and input and/or output functions, yellow LEDs located above the N-connectors are switched on.

Functions

On the transmitter side (TX), the RF FRONTEND serves the purpose of distributing internal RF signals to the outside to the various N-connectors (RF1, RF2, RF3OUT) and attenuate or amplify them according to the selected output and level.

On the receiver side (RX), its purpose is to internally distribute external RF signals from the different N-connectors (RF1, RF2, RF3OUT) and attenuate or amplify them according to the selected input and the applied level.

Since high levels and powers up to 50 W can be fed in on the receiver side (RX), the RF FRONTEND is equipped with power attenuators and the cooling system with the fan described above, which is controlled by the temperature at the power attenuators.

The RF FRONTEND additionally features two broadband power measuring diodes, which permit to measure the power applied at the N-connectors RF1, RF2, RF4IN even in pulsed operation.

RXTX BOARD1

The RXTX BOARD1 constitutes the central RF board which contains all circuit parts for conversion from RF to IF both for the transmitter (TX) and receiver (RX).

Design

The RXTX BOARD1 is designed as plug-in module with a silver-coated two-shell aluminum casing fixed with several screws.

Cooling system

This casing is equipped with cooling fins at the front and rear which are provided with a cover sheet each so that two special cooling ducts are produced. These cooling ducts are evenly cooled by the air flow of the instrument fan irrespective of neighboring modules.

This efficient cooling is required since a very high degree of integration and a large portion of fast RF components are implemented on this board.

Control and supply

Control and voltage supply of the RXTX BOARD1 are effected via a 96-pin FUTURE-bus connector from MOTHERBOARD1.

Complete function

For conversion from RF to IF, the transmitter side (TX) is implemented on one side of the multilayer PC board and the receiver side (RX) on the other side on the RXTX BOARD1. This strict separation of the functions permits to achieve high decouplings as they can usually only be achieved with two separate modules.

Transmitter functions

On the transmitter side (TX), an IF signal with 13.85 MHz is applied at the MMCX connector IF3TX1 (top of module) of the RXTX BOARD1, which is provided by the DIGITAL BOARD.

On the RXTX BOARD1, this signal is taken via various amplifier stages, attenuator pads and filters and finally set to the desired RF frequency by means of triple signal conversion (IF3, IF2, IF1). This is necessary to obtain a high image-frequency rejection.

At the TX output, a switchable attenuator with fine stepping and large attenuation range is used to set the RF signal amplitude according to the level selected.

The RF signal is finally taken to the RF FRONTEND at the SMA connector RFTX1 (bottom of module).

The transmitter side is provided with an extra LO1TX (Local Oscillator) with large tuning range and very fine frequency resolution used for setting the desired transmitter frequency, an LO2 fixed-frequency oscillator shared with the receiver side and an extra LO3TX with small tuning range. All LOs are synchronized by the MMCX connector 110.8MHz at the bottom of the module with the reference frequency from the REFERENCE BOARD.

Besides, an MMCX connector at the top of the RXTX BOARD1 is designed as input with the second transmitter IF (RESIF2TX) which is activated via software switches.

Receiver functions

On the receiver side (RX), the RF signal is fed in at the SMA connector RFRX1 (bottom of module) of the RXTX BOARD1 which is provided by the RF FRONTEND.

On the RXTX BOARD1, this signal is taken via a switchable attenuator with fine stepping and large attenuation range in order to match the level according to the level applied.

Subsequently, this signal is converted to an IF frequency of 10.7 MHz by means of triple signal conversion (IF1, IF2, IF3) and several filter and amplifier stages and provided at the MMCX connector IF3RX1 (top of module) for the DIGITAL BOARD.

This procedure is necessary to achieve a high image-frequency rejection and a high dynamic range with a simultaneously high intermodulation suppression.

For the receiver side, an extra LO1RX (local oscillator) is provided with a large tuning range and a very fine frequency resolution used for setting the receive frequency, an LO2 fixed-frequency oscillator shared with the transmitter and an extra LO3RX with a very small tuning range.

All LOs are synchronized by the MMCX connector 110.8 MHz at the bottom of the module with the reference frequency from the REFERENCE BOARD.

A further MMCX connector RESIF3RX (top of module) provides a buffered RX IF signal of 10.7 MHz which is taken to the rear of the R&S CMU via a coax cable. This signal output can be activated via a software switch.

Besides, an MMCX connector at the top of the RXTX BOARD1 is designed as output with the second receiver IF (RESIF2RX) which can be activated via software switches.

Correction processor

The RXTX BOARD1 contains an extra correction processor with large flash PROM.

It controls all the static and dynamic settings on the RXTX BOARD1 and, as a special feature, also the attenuator pads and amplifiers of the RX and TX attenuator on the RF FRONTEND.

Besides, the correction processor permits to read out the individual module error data from the EEPROMS of the respective modules in a so-called correction procedure (automatic module data adjustment) and calculate the deviations for all possible signal paths. These deviations are stored as correction values in the flash PROM. The correction processor then sets the desired level settings, corrected by the correction values, in the flash PROM so that frequency, linearity and temperature responses of the modules are compensated for.

This ensures the excellent level accuracy of the R&S CMU which is essential for most measurements.

Extension

The R&S CMU 200 can be extended by a RXTX BOARD2 and thus provide a second complete transmit and receive channel.

DIGITAL BOARD

The DIGITAL BOARD constitutes the central control and measurement board which contains all circuit parts for conversion and further processing of the analog IF (receiver side) into digital I/Q values. On the transmitter side, analog as well as digital I/Q values are modulated upon the carrier and provided as analog IF.

Design The DIGITAL BOARD is designed as HVC 200 plug-in module. The HVC 200 cabinet is equipped with a screwed-on cover both at the front and rear to ensure optimum electrical shielding of the module.

Cooling system The casing is provided with ventilation holes on the right and left in order to produce a large cooling flow through the module by means of the instrument fan. This efficient cooling is necessary, since a great number of highly integrated fast digital devices is used on the module and up to eight sandwich modules can additionally be fitted so that the board is densely packed.

Control and supply The control, bus lines and voltage supply of the DIGITAL BOARD are effected via four 96-pin and one 48-pin FUTURE-bus connectors from MOTHERBOARD1.

Function As standard, the four sandwich boards ADC Module1, DDC Module1, TXDSP Module1 and AUC Module1 are fitted. On the DIGITAL BOARD, all necessary clocks are generated and provided from the netclocks 1 and 2 in a clock conditioning and distribution circuit. These clocks are required for sampling, filtering and down converting the digital IF internally and for the UNIVERSAL SIGNALLING UNIT MODULE. Besides, two programmable logic devices (FPGA) are used on the DIGITAL BOARD, which provide address decoding, interrupt control and host interfaces between ISA bus and internal circuit parts (DDC/TXDSP) as well as the control of the RF FRONTEND (via FEI²C-Bus), the REFERENCE BOARD and AUDIO BOARD (via buffered ISA bus) and the RXTX BOARD1 (via serial bus). Further serial interfaces lead from the programmable logic devices to the UNIVERSAL SIGNALLING UNIT1 and vice versa. An AD converter on the DIGITAL BOARD is used for polling the diagnostic voltages of the R&S CMU modules, which can indicate module states and errors.

ADC MODULE1 The sandwich ADC MODULE1 is connected to the DIGITAL BOARD via a multipoint connector. In addition, it is screwed to a solid ground block to obtain a good ground connection. The ADC MODULE1 receives the analog IF (10.7 MHz) from the RXTX BOARD1 directly via a MMCX connector (IF3RX1) and converts it into a 12-bit data stream by means of a fast AD converter.

DDC MODULE1 The sandwich DDC MODULE1 is directly plugged onto the DIGITAL BOARD via three multipoint connectors and processes the digital data stream of the receiver. In a special ASIC chip, the I/Q shaping, the matching of the data rate and the respective filtering (bandwidth shaping) of the digital data stream are produced. Then follows a DSP (RX DSP) with further evaluation of the digital I/Q data for measurement purposes. Besides, the digital I/Q data are passed on via the MOTHERBOARD1 to the LINKHANDLER MODULE for evaluation.

TXDSP MODULE1	The sandwich TXDSP MODULE1 is directly plugged onto the DIGITAL BOARD via two multipoint connectors. It contains the DSP on the transmitter side (TXDSP), which generates I/Q data according to the application and provides them to the AUC MODULE1 via two 12-bit D/A converters and several selection switches located on the DIGITAL BOARD.
AUC MODULE1	The sandwich AUC MODULE1 is directly plugged onto the DIGITAL BOARD via a multipoint connector and serves the purpose of filtering the analog I/Q data from the TXDSP MODULE1 or the LINKHANDLER MODULE depending on the position of the selection switches on the DIGITAL BOARD according to the application (bandwidth shaping) and converting it to the transmit IF (13.85 MHz) by means of an I/Q modulator. Subsequently, the transmit IF is routed via the MMCX connector (IF3TX1) on the DIGITAL BOARD to the RXTX BOARD1.
Extension	The DIGITAL BOARD can be extended by a further complete receive and transmit channel consisting of ADC MODULE2, DDC MODULE2, TXDSP MODULE2 and AUC MODULE2.

Option UNIVERSAL SIGNALLING UNIT R&S CMU-B21 Var02

The UNIV. SIGN. UNIT MODULE is the control and measurement module which contains all circuit parts for signaling and measuring network-specific parameters.

To this end, the digital I/Q data from the DIGITAL BOARD are used on the receiver side (RX) in order to calculate test parameters.

On the transmitter side, analog network-specific I/Q data are generated and provided to the AUC MODULE1 on the DIGITAL BOARD.

Design	The UNIV. SIGN. UNIT MODULE is designed as plug-in module with two aluminum shell covers. It is equipped with a screwed-on aluminum cover both at the front and rear to allow for optimal electrical shielding of the module.
Cooling system	The casing is provided with ventilation holes on the right and left in order to produce a large cooling flow through the module by means of the instrument fan. This efficient cooling is necessary, since a great number of highly integrated fast digital devices is used on the module and up to seven sandwich modules can additionally be fitted so that the module is densely packed.
Control and supply	The control, bus lines and voltage supply of the UNIV. SIGN. UNIT MODULE are connected via two 96-pin VG multipoint connectors from MOTHERBOARD1. Further interfaces for testing and debugging are provided on the top of the module.
Function	As standard, the UNIV. SIGN. UNIT MODULE contains the three sandwich boards DSP MODULE0, DSP MODULE1 and IQOUT MODULE. Besides, if a very high computing power is required, two further DSP MODULES (DSP MODULE2, DSP MODULE3) and the SHARED MEMORY can be fitted. Furthermore, a slot for the Option R&S CMU-B52 SPEECH CODEC is provided. This option includes DSP MODULE3.

A microprocessor with peripheral equipment and two FPGA's on the UNIV. SIGN. UNIT control all the processes on the module.

An RS232 interface is available for debugging, data input and output. Besides, an ISA bus interface is installed for control and data communication with the FRONT MODULE CONTROLLER.

DSP MODULE

The two sandwich DSP MODULES (DSP MODULE0 and DSP MODULE1) are directly inserted on the UNIV. SIGN. UNIT via four multipoint connectors. Via a FIFO device, they receive the digital I/Q data from the DIGITAL BOARD for evaluation. The signal can then be demodulated by the DSP MODULES and the demodulated data can be passed on the protocol engine running on the MC or a DSP MODULE. The DSP MODULES can also perform some measurements and the results are passed on via the ISA bus interface to the FRONT MODULE CONTROLLER.

Likewise, the DSPs cause further actions on the transmitter side (TX), e.g. change transmit frequency-settings via the FPGA 'XILINX2' and output analog I/Q data via the IQOUT MODULE.

**Option BLUETOOTH
MODULE
R&S CMU-B53 Var02**

The option BLUETOOTH MODULE R&S CMU-B53 Var02 is directly inserted on the UNIV. SIGN. UNIT. It performs BLUETOOTH functionality.

Attention: This option includes the functionality of option SPEECH CODEC R&S CMU-B52 Var02. Therefore it is not necessary and possible to fit additionally the option SPEECH CODEC R&S CMU-B52 Var02.

IQOUT MODULE

The sandwich IQOUT MODULE is directly inserted on the UNIV. SIGN. UNIT via three multipoint connectors and installed in an extra shielding chamber, since it performs the digital-to-analog conversion of the I/Q data.

**Option SPEECH CODEC
R&S CMU-B52 Var02**

The Option SPEECH CODEC R&S CMU-B52 Var 02 (including DSP MODULE3) is also designed as sandwich module and is directly plugged onto the UNIV. SIGN. UNIT via three multipoint connectors. This option permits to read in and output analog speech signals (handsetin/out lines) via A/D and D/A converters.

Option UNIVERSAL SIGNALING UNIT R&S CMU-B21 Var 14/54

The UNIV. SIGN. UNIT MODULE is the control and measurement module which contains all circuit parts for signaling and measuring network-specific parameters.

To this end, the digital I/Q data from the DIGITAL BOARD are used on the receiver side (RX) in order to calculate test parameters.

On the transmitter side, analog network-specific I/Q data are generated and provided to the AUC MODULE1 on the DIGITAL BOARD.

Design	The UNIV. SIGN. UNIT MODULE is designed as plug-in module with two aluminum shell covers. It is equipped with a screwed-on aluminum cover both at the front and rear to allow for optimal electrical shielding of the module.
Cooling system	<p>The casing is provided with ventilation holes on the right and left in order to produce a large cooling flow through the module by means of the instrument fan.</p> <p>This efficient cooling is necessary, since a great number of highly integrated fast digital devices is used on the module and up to six sandwich modules can additionally be fitted so that the module is densely packed.</p>
Control and supply	The control, bus lines and voltage supply of the UNIV. SIGN. UNIT MODULE are connected via two 96-pin VG multipoint and one 48-pin VG multipoint connectors from MOTHERBOARD1. Further interfaces for testing and debugging are provided on the top of the module.
Function	<p>As standard, the UNIV. SIGN. UNIT MODULE VAR14 contains four DSP's (DSP 0 and DSP 1, CPDSP 1 and CPDSP 2) and is provided for six sandwich modules.</p> <p>As model Var54 the UNIV. SIGN. UNIT MODULE VAR54 contains UNIV. SIGN. UNIT MODULE VAR14 and the two sandwich boards MC68K MODULE and DSP2 MODULE.</p> <p>Besides, if a very high computing power is required, one further DSP MODULE (DSP MODULE3, Option R&S CMU-B55Var14) can be fitted.</p> <p>Furthermore, a slot for the Option R&S CMU-B52 SPEECH CODEC Var 14 is provided.</p> <p>Furthermore, a slot for the Option R&S CMU-B56 Var14/54 POWER PC MODULE is provided.</p> <p>One FPGA on the UNIV. SIGN. UNIT control all the processes on the module.</p> <p>An RS232 interface is available for debugging.</p> <p>Besides, an ISA bus interface is installed for control and data communication with the FRONT MODULE CONTROLLER.</p>
Option DSP MODULE 3 R&S CMU-B55 Var14	The sandwich DSP MODULE 3 R&S CMU-B55 Var14 is directly inserted on the UNIV. SIGN. UNIT. It performs more than two uplinks at GSM.
Option SIGNALING MODULE R&S CMU-B54 Var14	<p>The option SIGNALING MODULE R&S CMU-B54 Var14 contains the two sandwich boards DSP MODULE 2 and MC68K MODULE. These modules are directly inserted on the UNIV. SIGN. UNIT. It performs GSM, TDMA, AMPS functionality.</p> <p>Option R&S CMU-B54 Var14 is included in UNIV. SIGN. UNIT MODULE R&S CMU-B21 VAR54.</p>

**Option POWER PC
R&S CMU-B56 Var14**

The option POWER PC R&S CMU-B56 Var14 is directly inserted on the UNIV. SIGN. UNIT. It performs WCDMA signaling function. This option can be fitted only without the option R&S CMU-B56Var54.

**Option HIGH SPEED POWER
PC
R&S CMU-B56 Var54**

The option HIGH SPEED POWER PC R&S CMU-B56 Var54 is directly inserted on the UNIV. SIGN. UNIT. It performs high performance WCDMA signaling function at data end to end tests. This option can be fitted only without the option R&S CMU-B56Var14.

**Option BLUETOOTH
MODULE
R&S CMU-B53 Var14**

The option BLUETOOTH MODULE R&S CMU-B53 Var14 is directly inserted on the UNIV. SIGN. UNIT. It performs BLUETOOTH functionality.

Attention: For Bluetooth Speech Tests the Option SPEECH CODEC R&S CMU-B52 Var14 is additionally necessary.

**Option SPEECH CODEC
R&S CMU-B52 Var14**

The Option SPEECH CODEC R&S CMU-B52 Var14 (Speech Codec and DSP at one Sandwich module) is also designed as sandwich module and is directly plugged onto the UNIV. SIGN. UNIT. This option permits to read in and output analog speech signals (handsetin/out lines) via A/D and D/A converters.

Option AUDIO-GEN. + ANA. R&S CMU-B41

The Option AUDIO-GEN. + ANA. constitutes the central AF-board which contains all circuit parts for generation of AF output and analysis of AF input signals. The Option AUDIO-GEN. + ANA. is a plug-in module in HVC design.

Design	At the top of the module, eight MMCX connectors are attached, which serve as inputs or outputs for AF and clock signals and are routed to the respective modules or the integrated front panel with appropriate coax cables. There is also a coax cable to the loudspeaker on the front panel.
Connection	The plug-in module AUDIO-GEN. + ANA. is inserted in the R&S CMU on the right side on MOTHERBOARD2 using a 96-pin FUTURE-bus connector.
Function	<p>The Option AUDIO-GEN. + ANA. contains one DSP MODULE, a clock generation circuit, an analog input section and an analog output section. Further there is a power amplifier for the loudspeaker on this board.</p> <p>The DSP MODULE is a sandwich module, which controls the signal path, level and frequency of the AF output generator and also the signal path, attenuation and analysis of the AF input analyzer.</p> <p>The DSP MODULE is connected via an ISA-Bus Interface to the FRONTMODULE CONTROLLER of the R&S CMU.</p> <p>The clock generation circuit gets from the REFERENCE BOARD a 27.7MHz signal over a coax cable and a MMCX connector. This signal feeds the DSP MODULE and is converted in a PLL circuit to 24.576 MHz.</p> <p>Over a divider by 2 to. This clock signal divided by 2 (12.288MHz) is used for the A/D and D/A Converter IC and the serial links.</p>
Analog Input Section	<p>Over the BNC connectors AFIN and AUX1 at the front of the R&S CMU and the coax cables the AF signal comes to the analog input section, which provides two independent input channels.</p> <p>These two input channels could be used as one balanced or two unbalanced channels. Over an input attenuator and an various gain amplifier per channel the AF signal comes to the A/D Converter, which sends over a serial link connection the digital values to the DSP MODULE.</p>
Analog Output Section	<p>For the AF-Generator the DSP MODULE sends the digital values over a serial link connection to the D/A Converter of the analog output section.</p> <p>The analog output section provides two independent output channels, which could be used as one balanced or two unbalanced channels.</p> <p>Over a various gain amplifier and a switchable output attenuator the AF signal comes to the MMCX connectors, which are connected via coax cables to the BNC connectors AFOUT and AUX2 at the front of the R&S CMU.</p>

Option WCDMA L1COPRO R&S CMU-B66/68/76/78

The WCDMA L1COPRO MODULE is the control and measurement module which contains all circuit parts for signaling and measuring network-specific parameters.

To this end, the analog IF signal from the RXTX BOARD are used on the receiver side (RX) in order to calculate test parameters (only with R&S CMU-B68/78).

On the transmitter side, analog network-specific IF signal data are generated and provided to the RXTX MODULE.

Design	The WCDMA L1COPRO MODULE is designed as plug-in module with two aluminum shell covers. It is equipped with a screwed-on aluminum cover both at the front and rear to allow for optimal electrical shielding of the module.
Cooling system	<p>The casing is provided with ventilation holes on the right and left and additional cooling fins at the rear which are provided with a cover sheet so that one special cooling duct are produced in order to produce a large cooling flow through the module and the duct by means of the instrument fan.</p> <p>This efficient cooling is necessary, since a great number of highly integrated fast digital devices is used on the module and up to four sandwich modules can additionally be fitted so that the module is densely packed.</p>
Control and supply	The control, bus lines and voltage supply of the WCDMA L1COPRO MODULE are connected via two 96-pin VG and one 48-pin VG multipoint connectors from MOTHERBOARD1. Further interfaces for IF IN and IF OUT are provided on the top of the module.
Function	<p>As standard (R&S CMU-B66/76), the WCDMA L1COPRO MODULE contains the two sandwich boards WTX MODULE and TX-FEC MODULE.</p> <p>As Option R&S CMU-B68/78, the WCDMA L1COPRO MODULE contains the two two sandwich boards WTX MODULE, TX-FEC MODULE and additional the two sandwich boards WDDC MODULE and RX-FEC MODULE.</p> <p>Three FPGA's on the WCDMA L1COPRO MODULE control all the processes on the module. Two DSP's, one for TX and one for RX, generate and analyse the signals TX-FEC MODULE and RX-FEC MODULE. See Figure 3-2 for a simplified block diagram.</p> <p>Besides, an ISA bus interface is installed for control and data communication with the FRONT MODULE CONTROLLER.</p>
WTX MODULE	The sandwich WTX MODULE is directly inserted on the WCDMA L1COPRO MODULE. It performs the digital-to-analog conversion of the TX IF output signal.
TX-FEC MODULE	The sandwich TX-FEC MODULE is directly inserted on the WCDMA L1COPRO MODULE. It performs the forward error correction of the digital TX data.
WDDC MODULE (only with Option R&S CMU-B68/78)	The sandwich WDDC MODULE is directly inserted on the WCDMA L1COPRO MODULE. It performs the analog-to-digital conversion of the RX IF input signal.
RX-FEC MODULE (only with Option R&S CMU-B68/78)	The sandwich RX-FEC MODULE is directly inserted on the WCDMA L1COPRO MODULE. It performs the forward error correction of the digital RX data.

Option CDMA (IS95) Signaling Unit R&S CMU-B81

The CDMA (IS95) Signalling Unit is a module of the R&S CMU200 providing signalling and measuring support for the CDMA IS-95 cellular phone network.

With the use of analog and digital hardware and firmware, this module uses the down converter and a signal generator in the R&S CMU200 to establish a link with a CDMA mobile station.

Design The CDMA (IS95) Signalling Unit is a plug-in module with a complete aluminum shell providing optimal electrical shielding of the module.

Cooling system Ventilation holes on the right and left of the shell produces a large cooling flow through the module by means of the instrument fan.

Control and supply The MOTHERBOARD 1 provides bus lines, the voltage supply, and controls the CDMA (IS95) Signalling Unit via two 96-pin connectors and one 48-pin connector. Further interfaces for testing and debugging are provided on the top of the module.

Function The CDMA (IS95) Signalling Unit contains the hardware for signal demodulation and signal generation of a CDMA system. See Figure 3-2 for a simplified block diagram.

A micro processor with peripheral equipment and three programmable logic devices (Xilinx 1, 2, and 3) on the board control all the processes on the module.

An RS232 interface is available for debugging and data input and output.

An AT-bus interface is used for control and data communication with the front module computer.

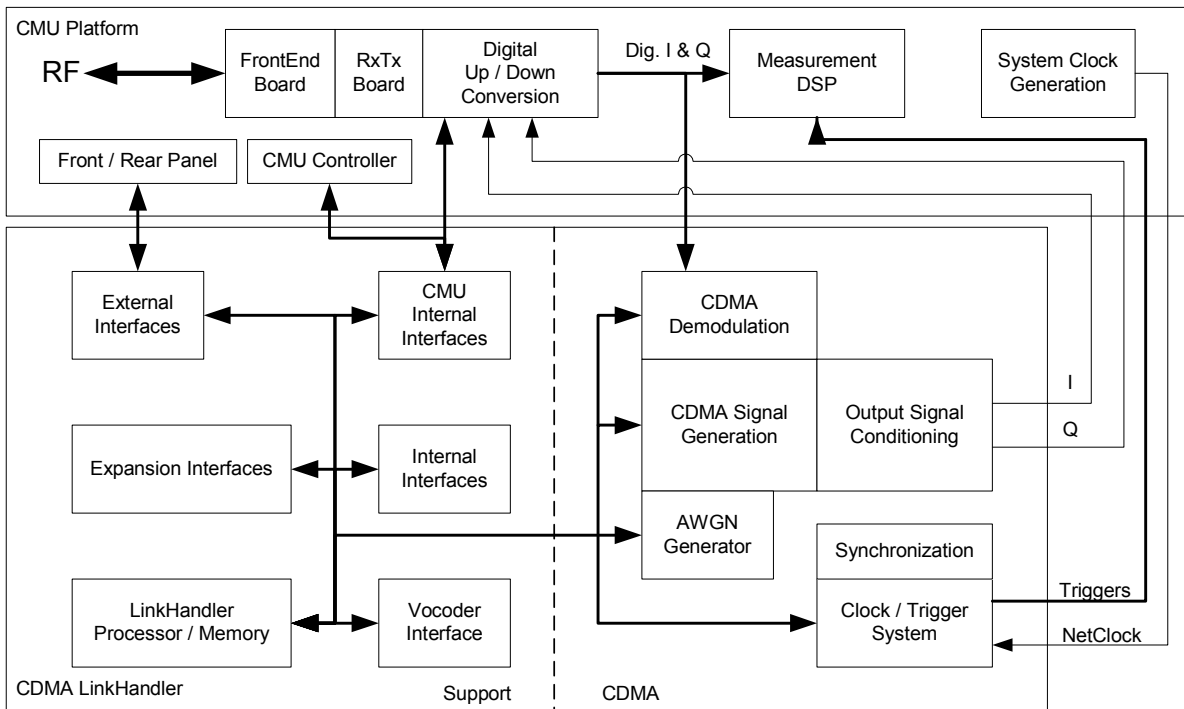

Figure 3-2: CDMA (IS95) Signalling Unit block diagram

Option CDMA2000 Signaling Unit R&S-B83 Var12

The CDMA2000 Signalling Unit is a module of the R&S CMU200 providing signalling and measuring support for the CDMA2000 cellular phone network.

With the use of analog and digital hardware and firmware, this module uses the down converter and a signal generator in the R&S CMU200 to establish a link with a CDMA mobile station.

Design	The CDMA2000 Signalling Unit is a plug-in module with a complete aluminum shell providing optimal electrical shielding of the module.
Cooling system	Ventilation holes on the right and left of the shell produces a large cooling flow through the module by means of the instrument fan.
Control and supply	The MOTHERBOARD 1 provides bus lines, the voltage supply, and controls the CDMA2000 Signalling Unit via two 96-pin connectors and one 48-pin connector. Further interfaces for testing and debugging are provided on the top of the module.
Function	<p>The CDMA2000 Signalling Unit contains the hardware for signal demodulation and signal generation of a CDMA2000 system. See Figure 3-2 for a simplified block diagram.</p> <p>A POWER PC with peripheral equipment and one FPGA with peripheral ASIC on the board control all the processes on the module</p> <p>An Ethernet interface is available for data input and output (Option R&S CMU-B87).</p> <p>An RS232 interface is available for debugging.</p> <p>An AT-bus interface is used for control and data communication with the front module computer.</p>
1xEV-DO Module R&S CMU-B88	The Option 1xEV-DO Module R&S CMU-B88 is designed as sandwich module and is directly plugged onto the CDMA2000 SIGN. UNIT. This option permits to generate 1xEV-DO TX Non Signaling signals.
Access Module R&S CMU-B82	<p>The Option Access Module R&S CMU-B82 is designed as sandwich module and is directly plugged onto the CDMA2000 SIGN. UNIT. An additional cable to the rearpanel of the R&S CMU is included. This option permits access to the special Access Interface.</p> <p>This option can be fitted only without the option R&S CMU-B85.</p>
Speech Codec Module R&S CMU-B85 VAR02	<p>The Option SPEECH CODEC R&S CMU-B85 is designed as sandwich module and is directly plugged onto the CDMA2000 SIGN. UNIT. This option permits to read in and output analog speech signals (handsetin/out lines) via A/D and D/A converters.</p> <p>This option can be fitted only without the option R&S CMU-B82.</p>
Message Monitor R&S CMU-B87	This Option Message Monitor R&S CMU-B87 is designed as a cable to connect the CDMA2000 SIGN. UNIT with the rearpanel of the R&S CMU

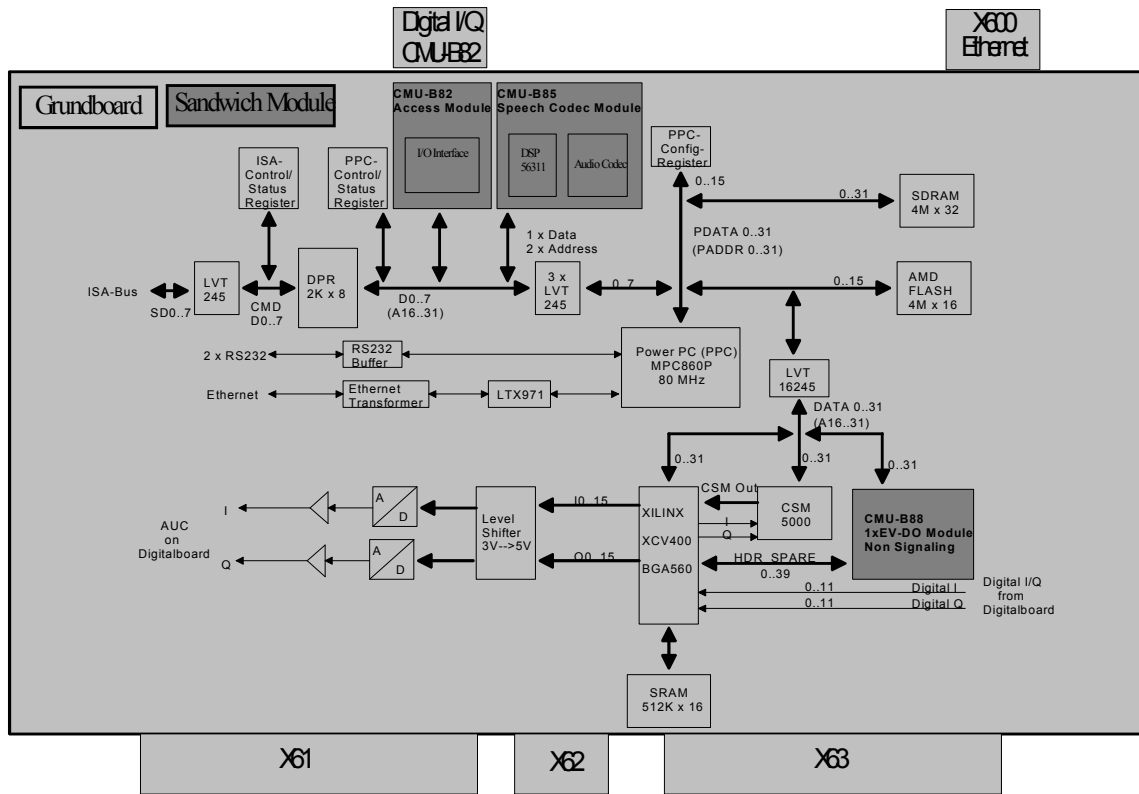

Figure 3-3: CDMA2000 Var12 Signalling Unit block diagram

Option CDMA2000 Signalling Unit R&S CMU-B83 Var22

The CDMA2000 Signalling Unit is a module of the R&S CMU200 providing signalling and measuring support for the CDMA2000 cellular phone network.

With the use of analog and digital hardware and firmware, this module uses the down converter and a signal generator in the R&S CMU200 to establish a link with a CDMA mobile station.

Design The CDMA2000 Signalling Unit is a plug-in module with a complete aluminum shell providing optimal electrical shielding of the module.

Cooling system Ventilation holes on the right and left of the shell produces a large cooling flow through the module by means of the instrument fan.

Control and supply The MOTHERBOARD 1 provides bus lines, the voltage supply, and controls the CDMA2000 Signalling Unit via two 96-pin connectors and one 48-pin connector. Further interfaces for testing and debugging are provided on the top of the module.

Function The CDMA2000 Signalling Unit contains the hardware for signal demodulation and signal generation of a CDMA2000 system. See Figure 3-2 for a simplified block diagram.

A high performance POWER PC Module with peripheral equipment and one FPGA with peripheral ASIC on the board control all the processes on the module

An Ethernet interface is available for data input and output (Option R&S CMU-B87).

An RS232 interface is available for debugging.

An AT-bus interface is used for control and data communication with the front module computer.

**1xEV-DO Module
R&S CMU-B89**

The Option 1xEV-DO Module R&S CMU-B89 is designed as sandwich module and is directly plugged onto the CDMA2000 SIGN. UNIT Var22. This option permits to generate 1xEV-DO Signaling signals.

**Speech Codec Module
R&S CMU-B85 Var22**

The Option SPEECH CODEC R&S CMU-B85 Var22 is designed as sandwich module and is directly plugged onto the CDMA2000 SIGN. UNIT. This option permits to read in and output analog speech signals (handsetin/out lines) via A/D and D/A converters.

**Message Monitor
R&S CMU-B87**

This Option Message Monitor R&S CMU-B87 is designed as a cable to connect the CDMA2000 SIGN. UNIT with the rearpanel of the R&S CMU

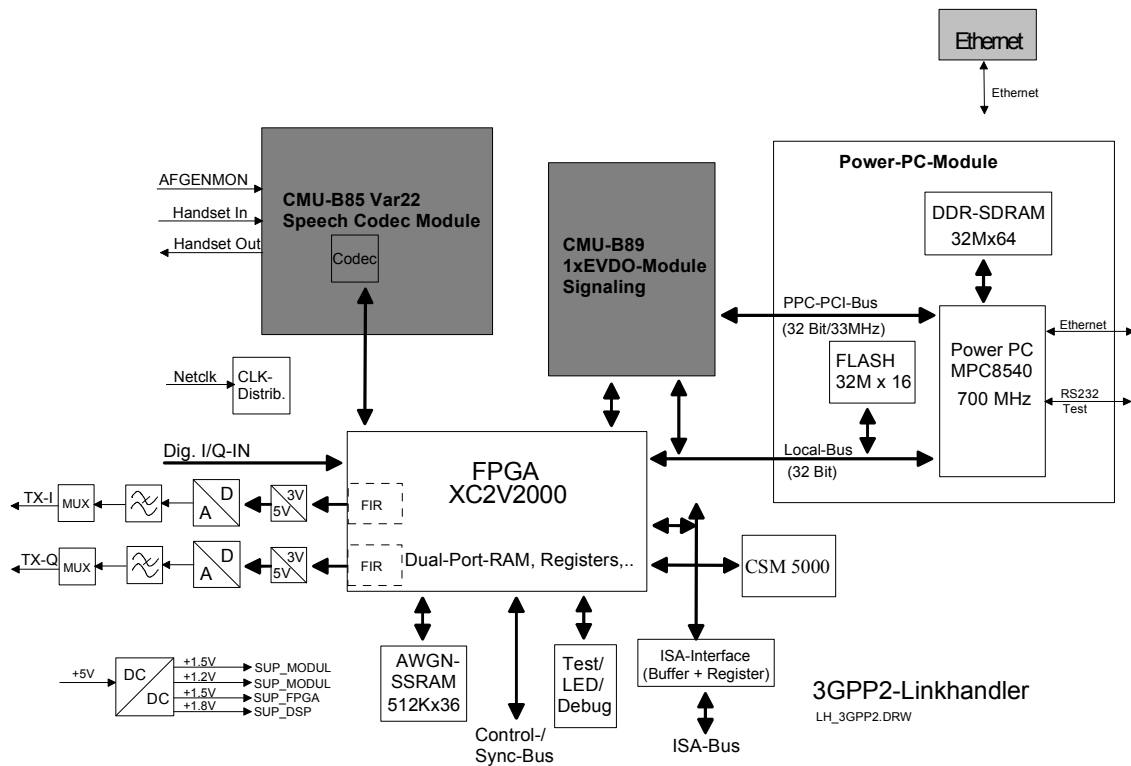

Figure 3-4: CDMA2000 Var22 Signalling Unit block diagram

MODULE Replacement



Caution!

Disconnect the instrument from the mains before opening the casing. Please note the safety instructions at the beginning of this manual.

When mounting the tube take care not to damage or pull off cables.

Replacing the FRONT MODULE

(see chapter 5, spare part list, Current No. 10X to 103, and explosion drawing 1100.0008.01 D sheet 2)

For replacement proceed as follows:

Opening the instrument and removing the FRONT MODULE

- Switch off the instrument, pull the mains plug and unscrew the rear-panel feet.
- Place the instrument onto the front carrying handles, push the tube upwards and take off.
- Unscrew the four screws of the front handles at the instrument frame on both sides and take off the front handles.
- Unscrew a countersunk screw (if present) at the front on the labeling panel next to the spinwheel and pull off the labeling panel towards the front.
- Unscrew two countersunk screws in the front frame at the top and at the bottom as well as two countersunk screws at the front above the AUX1/2 BNC connectors.
- Unscrew a combi screw at the top of the module support for support of the Option FLOPPY DISK DRIVE R&S CMU-U61 or PCMCIA INTERFACE.
- After unscrewing the two countersunk screws at the top left instrument frame slightly lift the cover at the top of the instrument, slightly shift towards the right and lift off.
- Slightly push the FRONT MODULE from the rear to the front using little pressure.
 - Note:** *Note the connecting cables for the Option FLOPPY DISK DRIVE R&S CMU-U61 or PCMCIA INTERFACE that are still connected to the MOTHERBOARD1.*
- After sliding out the FRONT MODULE disconnect the respective connecting cable for the option from the MOTHERBOARD1 as follows:
 - Option FLOPPY DISK DRIVE R&S CMU-U61: The connecting cable is a film cable.
 - Lift the locking bracket of the connector on the MOTHERBOARD and remove the film cable.
 - PCMCIA INTERFACE: The connecting cable consists of three ribbon cables.
 - Disconnect the three ribbon cables from the MOTHERBOARD1 connector.
- Take the FRONT MODULE completely out of the R&S CMU.
- Unscrew the two countersunk screws at the cover of the Option FLOPPY DISK DRIVE R&S CMU-U61 or PCMCIA INTERFACE and carefully pull the option towards the front out of the FRONT MODULE.

Installing the new FRONT MODULE and completing the instrument

- Install the old Option FLOPPY DISK DRIVE R&S CMU-U61 or PCMCIA INTERFACE in a new FRONT MODULE in the reverse order.
- Install the new FRONT MODULE in the R&S CMU in the reverse order.
Caution: Make sure to route the cables of the Option FLOPPY DISK DRIVE R&S CMU-U61 or PCMCIA INTERFACE properly, not to catch them and plug them into the MOTHERBOARD before completely sliding the FRONT MODULE into the R&S CMU.
- Complete the instrument without causing damage to the cables.

Putting into operation

- Connect the instrument to the mains and switch on: The built-in FRONT MODULE CONTROLLER registers on the LCD. The BIOS is factory-set to the R&S CMU.
- If necessary, load new software to the FRONT MODULE (see chapter 4, *Firmware update*).
- During startup observe the display.
- When three BEEPs can be heard, press the *MENU SELECT* key.
The Version Manager is started (see also chapter 4, *Firmware update*).
The display includes the menu item *FIRMWARE UPDATE AFTER BOARD CHANGE*.
- Press the softkey to the left of the above mentioned menu item.
The automatic module data adjustment is performed under software control, firmware updates for microprocessors and programmable devices being also performed on the modules. This may take a few minutes.

After the adjustment has been terminated, the operating software starts automatically and the R&S CMU is ready for use and can be operated as usual.

Replacing the FRONT MODULE CONTROLLER in the FRONT MODULE

(see chapter 5, spare part list, Current No. 11X/12X and explosion drawing 1090.9244.01 D sheet 3)

The FRONT MODULE CONTROLLER is incorporated in the FRONT MODULE. For replacement proceed as follows:

Opening the instrument and removing the FRONT MODULE

- Switch off the instrument, pull the mains plug and unscrew the rear-panel feet.
- Place the instrument onto the front carrying handles, push the tube upwards and take off.
- Unscrew the four screws of the front handles at the instrument frame on both sides and take off the front handles.
- Unscrew a countersunk screw (if present) at the front on the labeling panel next to the spinwheel and pull off the labeling panel towards the front.
- Unscrew two countersunk screws in the front frame at the top and at the bottom as well as two countersunk screws at the front above the AUX1/2 BNC connectors.
- Unscrew a combi screw at the top of the module support for support of the Option FLOPPY DISK DRIVE R&S CMU-U61 or PCMCIA INTERFACE.
- After unscrewing the two countersunk screws at the top left instrument frame slightly lift the cover at the top of the instrument, slightly shift towards the right and lift off.
- Slightly push the FRONT MODULE from the rear to the front using little pressure.
Note: Note the connecting cables for the Option FLOPPY DISK DRIVE R&S CMU-U61 or PCMCIA INTERFACE that are still connected to the MOTHERBOARD1.
- After sliding out the FRONT MODULE disconnect the respective connecting cable for the option from the MOTHERBOARD1 as follows:
 - Option FLOPPY DISK DRIVE R&S CMU-U61: The connecting cable is a film cable.
 - Lift the locking bracket of the connector on the MOTHERBOARD1 and remove the film cable.
 - PCMCIA INTERFACE: The connecting cable consists of three ribbon cables.
 - Disconnect the three ribbon cables from the MOTHERBOARD1 connector.
- Take the FRONT MODULE completely out of the R&S CMU.

Removing the FRONT MODULE CONTROLLER from the FRONT MODULE

- Unscrew the two countersunk screws on the cover of the Option FLOPPY DISK DRIVE R&S CMU–U61 or PCMCIA INTERFACE and carefully pull out the option from the FRONT MODULE towards the front.
- Place the FRONT MODULE onto a clean surface with the aluminum panel pointing downwards.
- Unscrew the four screws on the mounting plate at the top, bottom and left and carefully swing away the mounting plate towards the rear.
- Pull off the connecting cables to the LCD, DC/AC illumination converter, keyboard membrane and spinwheel.

Note: *When pulling off the connecting cables be careful with the cable connecting to the keyboard. It is a film cable which can only be disconnected after sliding up the lock of the film cable plug. Besides, be careful with the ribbon cable connecting to the spinwheel. First loosen the locking brackets of the plug.*

- **MODEL 12, 22, 23, 24:** Pull off the ribbon cable from the hard disk to the FRONT MODULE CONTROLLER.
- Disconnect the fan cable from the printed circuit board of the FRONT MODULE CONTROLLER.
- Unscrew the eleven combi screws of the FRONT MODULE CONTROLLER board and take out the FRONT MODULE CONTROLLER.

Installing the new FRONT MODULE CONTROLLER

- Carefully insert the new FRONT MODULE CONTROLLER, fasten using the eleven combi screws and reconnect the cable to the fan.
- **MODEL 12, 22, 23, 24:** Carefully reconnect the ribbon cable to the FRONT MODULE CONTROLLER.
- Replace the memory modules from the old into the new FRONT MODULE CONTROLLER (see replacing the memory modules).
- Carefully insert the cable connectors to the controller board, taking care not to reverse the polarities, and replace the mounting plate in the reverse order.

Installing the option again and completing the instruments

- Replace the old Option FLOPPY DISK DRIVE R&S CMU–U61 or PCMCIA INTERFACE in the FRONT MODULE in the reverse order.
- To install the FRONT MODULE1 in the R&S CMU again proceed in the reverse order.

Note: *Make sure to route the cables of the Option FLOPPY DISK DRIVE R&S CMU–U61 or PCMCIA INTERFACE properly, not to catch them and insert them on the MOTHERBOARD1 before sliding the FRONT MODULE completely into the R&S CMU.*
- Complete the instrument without causing damage to the cables.

Putting into operation

- Connect the instrument to the mains.
- Connect the external keyboard to the keyboard connector on the rear panel of the R&S CMU.
- Switch on the R&S CMU.
- During startup observe the display.
- When three BEEPs can be heard, press the softkey to the left upper side of the LCD: **C:** will appear.
- **MODEL 12:**
 - Insert a flash disk with the program FLASH FMR5 (this program is available on R & S Lotus Notes Service Board) in the PCMCIA slot 0 (right drive D:) or a floppy disk with the program FLASH FMR5 in the Option FLOPPY DISK DRIVE R&S CMU-U61.
 - Start program FLASH FMR5 with D:\ FLASHFM5.BAT or A:\ FLASHFM5.BAT.
- **MODEL 22, 23, 24:**
 - Insert a flash disk with the program FLASH FMR6/X (this program is available on R & S Lotus Notes Service Board) in the PCMCIA slot 0 (right drive D:) or a floppy disk with the program FLASH FMR6 in the Option FLOPPY DISK DRIVE CMU-U61.
 - Start program FLASH FMR6/X with D:\ FLASHFM6.BAT or A:\ FLASHFM6.BAT.
- During the programming of the flash EEPROM the R&S CMU must not be switched off.
- When the prompt C:\ appears then switch off and on the R&S CMU.
- Press the key *DEL* (Delete) on the external keyboard in order to get into the Setup menu.
- Choose the item LOAD CMU-DEFAULTS (MODEL 12)/ LOAD CMU-DEFAULTS (MODEL 2X) and press *ENTER*; quit with *y* and *ENTER*.
- Only if Option FLOPPY DISK DRIVE R&S CMU-U61 is fitted, then choose the item Setup Standard and set FLOPPY A to '1.44 MB 3 ½'. Exit with the *ESC* key.
- Exit Bios Setup with key *ESC* and quit with *y* (save changes and exit) and press *ENTER*.

The R&S CMU starts the operating software automatically, it is ready for use and can be operated as usual.

Replacing the Lithium Battery in the FRONT MODULE

(see chapter 5, spare part list, Current No. 21X and explosion drawing 1090.9244.01 D sheet 3)

The lithium battery is accommodated on the FRONT MODULE CONTROLLER board inside the FRONT MODULE. For replacement proceed as follows:

Note: *Data in the CMOS RAM will be lost when replacing the lithium battery.*

Opening the instrument and removing the FRONT MODULE

- Switch off the instrument, pull the mains plug and unscrew the rear-panel feet.
- Place the instrument onto the front carrying handles, push the tube upwards and take off.
- Unscrew the four screws of the front handles at the instrument frame on both sides and take off the front handles.
- Unscrew a countersunk screw (if present) at the front on the labeling panel next to the spinwheel and pull off the labeling panel towards the front.
- Unscrew two countersunk screws in the front frame at the top and at the bottom as well as two countersunk screws at the front above the AUX1/2 BNC connectors.
- Unscrew a combi screw at the top of the module support for support of the Option FLOPPY DISK DRIVE R&S CMU-U61 or PCMCIA INTERFACE.
- After unscrewing the two countersunk screws at the top left instrument frame slightly lift the cover at the top of the instrument, slightly shift towards the right and lift off.
- Slightly push the FRONT MODULE from the rear to the front using little pressure.
 - Note:** *Note the connecting cables for the Option FLOPPY DISK DRIVE R&S CMU-U61 or PCMCIA INTERFACE that are still connected to the MOTHERBOARD1.*
- After sliding out the FRONT MODULE disconnect the respective connecting cable for the option from the MOTHERBOARD1 as follows:
 - Option FLOPPY DISK DRIVE R&S CMU-U61: The connecting cable is a film cable.
 - Lift the locking bracket of the connector on the MOTHERBOARD1 and remove the film cable.
 - PCMCIA INTERFACE: The connecting cable consists of three ribbon cables.
 - Disconnect the three ribbon cables from the MOTHERBOARD1 connector.
- Take the FRONT MODULE completely out of the R&S CMU.

Removing the lithium battery and installing the new battery

- Unscrew the two countersunk screws on the cover of the Option FLOPPY DISK DRIVE R&S CMU–U61 or PCMCIA INTERFACE and carefully pull out the option from the FRONT MODULE towards the front.
- Place the FRONT MODULE onto a clean surface with the aluminum panel pointing downwards.
- Unscrew the four screws on the mounting plate at the top, bottom and right and carefully swing away the mounting plate towards the rear.
- Pull off the connecting cables to the LCD, DC/AC illumination converter, keyboard membrane and spinwheel.

Note: *When pulling off the connecting cables be careful with the cable connecting to the keyboard. It is a film cable which can only be disconnected after sliding up the lock of the film cable plug. Besides, be careful with the ribbon cable connecting to the spinwheel. First loosen the locking brackets of the plug.*

- Locate the lithium battery on the controller board (see chapter 5, explosion drawing 1090.9244.01 D sheet 3).
- **MODEL 12:**
 - Unplug jumper J12 (MODEL 12)
 - Carefully unsolder the negative terminal from the soldering lug first using the soldering iron (medium temperature). Then unsolder the positive terminal. If necessary, remove the mechanical lock (cable clamp) and take out the battery.
 - Shorten the length of the connecting wires of the new battery as with the old battery and replace with the correct polarity.

Note: *Do not short-circuit the battery!*

Note: *The lithium battery is of the type 3.6 V (\varnothing 15 mm * 25 mm) with soldering lug terminals (spare part list, Current No. 210).*

- If necessary, replace the mechanical lock (cable clamp). First solder the positive terminal to the PC board, then the negative terminal.
- Plug jumper J12 first to the position middle and left (position RAM discharge) and then to middle and right position. Leave jumper J12 at this position (position before battery replacement).

- **MODEL 22, 23, 24:**

- Press out the battery from the batteryholder
- Replace battery with the correct polarity

Note: *Do not short-circuit the battery!*

Note: *The lithium battery is of the type 3.0 V (spare part list, Current No. 211).*

Caution!

Lithium batteries must not be exposed to high temperatures or fire.

Keep away from children.

If the battery is replaced improperly, there is danger of explosion. Only replace the battery by R&S type).

Lithium batteries are hazardous waste and must be disposed of in dedicated containers.

Do not short-circuit the battery!



Completing the instrument

- Carefully plug the cable connectors to the controller board without reversing the polarities and replace the mounting plate in the reverse order.
- Install the old Option FLOPPY DISK DRIVE R&S CMU–U61 or PCMCIA INTERFACE in the FRONT MODULE in the reverse order.
- Install the FRONT MODULE in the R&S CMU in the reverse order.

Note: *Make sure to route the cables of the Option FLOPPY DISK DRIVE R&S CMU–U61 or PCMCIA INTERFACE properly, not to catch them and insert them on the MOTHERBOARD1 before sliding the FRONT MODULE completely into the R&S CMU.*

- Complete the instrument without causing damage to the cables.

Putting into operation

- Connect the instrument to the mains.
- Connect the external keyboard to the keyboard connector on the rear panel of the R&S CMU.
- Switch on the R&S CMU.
- Press the key DEL (Delete) on the external keyboard in order to get into the Setup menu
- Choose the item LOAD R&S CMU-DEFAULTS (MODEL 12) / LOAD CMU-DEFAULTS (MODEL 2X) and press ENTER; quit with y and ENTER.
- Choose the item Setup Standard and set date and time. Exit with ESC key.
- Exit BIOS Setup with the key ESC and quit with y (save changes and exit) and ENTER.

The R&S CMU starts the operating software automatically, it is ready for use and can be operated as usual.

Replacing the Hard Disk in the FRONT MODULE

(see chapter 5, *spare part list*, *Current No. 260* and *explosion drawing 1090.9244.01 D sheet 3*)

The hard disk is incorporated in the FRONT MODULE (MODULE 04) or outside on the back of the aluminum panel of the FRONT MODULE (MODEL 12/22/23/24). For replacement proceed as follows:

Opening the instrument and removing the FRONT MODULE

- Switch off the instrument, pull the mains plug and unscrew the rear-panel feet.
- Place the instrument onto the front carrying handles, push the tube upwards and take off.

Removing the hard disk from the FRONT MODULE

MODEL 12, 22, 23, 24:

- After unscrewing the two countersunk screws at the top left instrument frame, slightly lift the cover at the top of the instrument, slightly shift towards the right and lift off.
- Remove the ribbon cable from the hard disk to the FRONT MODULE CONTROLLER, unscrew the two screws on the back of the aluminum panel of the FRONT MODULE and pull out the harddisk. Unscrew the hard disk from the disk holder.

Installing the new hard disk

MODEL 12, 22, 23, 24:

- Carefully fit the new hard disk, fasten with the four screws to the disk holder. Insert the hard disk with the disk holder on the back of the aluminum case of the FRONT MODULE. Be careful with the lower cover plate locking in the concerning opening. Connect the ribbon cable to the FRONT MODULE CONTROLLER. Fit the disk holder with two screws to the aluminum panel of the FRONT MODULE.

Note: *The hard disk is an IDE hard disk which can be obtained under R&S spare part list, Current No. 260. It is already formatted for the R&S CMU and contains the operating system.*

- Complete the instrument without causing damage to the cables.

Putting into operation

- Connect the instrument to the mains and switch on: The built-in *FRONT MODULE CONTROLLER* registers on the LCD. The BIOS is factory-set to the R&S CMU, the new hard disk is automatically detected.
- Install the new software (see chapter 4, *Firmware update*).

Replacing the Memory Modules in the FRONT MODULE

(see chapter 5, spare part list, Current No. 220 (MODEL 12 or)
Current No. 23X (MODEL 22/23/24) and explosion drawing 1090.9244.01 D sheet/3)

The memory modules are incorporated in the FRONT MODULE. The FRONT MODULE CONTROLLER features two SODIMM-144 slots, but only one 256 MB memory can be fitted (MODEL 12) or two SODIMM-144 slots, in each of which up to 256 MB memory can be fitted (MODEL 22/23/24). The BIOS automatically detects the size of the memory modules. For replacement proceed as follows:

Opening the instrument and removing the FRONT MODULE

- Switch off the instrument, pull the power plug, unscrew the rear-panel feet.
- Place the instrument onto the front carrying handles, push the tube upwards and take off.
- Unscrew the four screws of the front handles from the instrument frame on both sides and take off the front handles.
- Unscrew a countersunk screw (if present) at the front on the labeling panel next to the spinwheel and pull off the labeling panel towards the front.
- Unscrew two countersunk screws in the front frame at the top and at the bottom as well as two countersunk screws at the front above the AUX1/2 BNC connectors.
- Unscrew a combi screw at the top of the module support for support of the Option FLOPPY DISK DRIVE R&S CMU-U61 or PCMCIA INTERFACE.
- After unscrewing the two countersunk screws at the top left instrument frame slightly lift the cover at the top of the instrument, slightly shift towards the right and lift off.
- Slightly push the FRONT MODULE from the rear to the front using little pressure.
Note: Note the connecting cables for the Option FLOPPY DISK DRIVE R&S CMU-U61 or PCMCIA INTERFACE that are still connected to the MOTHERBOARD1.
- After sliding out the FRONT MODULE disconnect the respective connecting cable for the option from the MOTHERBOARD as follows:
 - Option FLOPPY DISK DRIVE R&S CMU-U61: The connecting cable is a film cable.
 - Lift the locking bracket of the connector on the MOTHERBOARD1 and remove the film cable.
 - PCMCIA INTERFACE: The connecting cable consists of three ribbon cables.
 - Disconnect the three ribbon cables from the MOTHERBOARD1 connector.
- Take the FRONT MODULE completely out of the R&S CMU.

Making the memory modules accessible

- Unscrew the two countersunk screws on the cover of the Option FLOPPY DISK DRIVE R&S CMU–U61 or PCMCIA INTERFACE and carefully pull out the option from the FRONT MODULE towards the front.
- Place the FRONT MODULE onto a clean surface with the aluminum panel pointing downwards.
- Unscrew the four screws on the mounting plate at the top, bottom and right and carefully swing away the mounting plate towards the rear.
- Pull off the connecting cables to the LCD, DC/AC illumination converter, keyboard membrane and spinwheel.

Note: *When pulling off the connecting cables be careful with the cable connecting to the keyboard. It is a film cable which can only be disconnected after sliding up the lock of the film cable plug. Besides, be careful with the ribbon cable connecting to the spinwheel. First loosen the locking brackets of the plug.*

Removing the memory module

- Remove the old module: Carefully bend the lateral brackets towards the outside and pull out the memory module.

Installing the new memory module and completing the instrument

- Insert the new module: insert the memory module into the slot, slightly press towards the rear and engage the brackets on the sides.

MODEL 12: *The memory modules can be obtained with the size 256 MB (spare part list, Current No. 220) It is possible to insert one of these modules. It is not recommended to fit more than 256 MB in sum. First fit slot 1 (U24).*

MODEL 22/23/24: *The memory modules can be obtained with the size 256 MB (spare part list, Current No. 23X) It is possible to insert two of these modules, even of different size. First fit slot 1 (U2) and then slot 2 (U3).*

- Carefully plug the cable connectors to the controller board without reversing the polarities and replace the mounting plate in the reverse order.
- Install the old Option FLOPPY DISK DRIVE R&S CMU–U61 or PCMCIA INTERFACE in the FRONT MODULE in the reverse order.

Note: *Make sure to route the cables of the Option FLOPPY DISK DRIVE R&S CMU–U61 or PCMCIA INTERFACE properly, not to catch them and insert them on the MOTHERBOARD before sliding the FRONT MODULE completely into the R&S CMU.*

- Complete the instrument without causing damage to the cables.

Putting into operation

- Connect the instrument to the mains and switch on. The built-in FRONT MODULE CONTROLLER registers on the LCD. The BIOS is factory-set to the R&S CMU.
- If required, supplement the BIOS Setup as follows:
 - Connect external keyboard to keyboard connector on the rear panel of the R&S CMU.
 - If the message 'CMOS Memory Size wrong, RUN SETUP, Press F1 to resume' appears, press the F1 key.
 - Quit the BIOS setup using the ESC key and the RETURN key.

The R&S CMU starts the operating software automatically and is ready for use and can be operated as usual.

Replacing the LCD and/or DC/AC Converter in the FRONT MODULE

(see chapter 5, spare part list, LCD: Current No. 250, DC/AC Converter: Current No. 253 and explosion drawing 1090.9244.01 D sheet 3)

The LCD is accommodated on the mounting plate of the FRONT MODULE together with the associated DC/AC converter. It is connected to the FRONT MODULE CONTROLLER via cables, which can also be replaced individually. For replacement proceed as follows:

Opening the instrument and removing the FRONT MODULE

- Switch off the instrument, pull the mains plug and unscrew the rear-panel feet.
- Place the instrument onto the front carrying handles, push the tube upwards and take off.
- Unscrew the four screws of the front handles at the instrument frame on both sides and take off the front handles.
- Unscrew a countersunk screw (if present) at the front on the labeling panel next to the spinwheel and pull off the labeling panel towards the front.
- Unscrew two countersunk screws in the front frame at the top and at the bottom as well as two countersunk screws at the front above the AUX1/2 BNC connectors.
- Unscrew a combi screw at the top of the module support for support of the Option FLOPPY DISK DRIVE R&S CMU-U61 or PCMCIA INTERFACE.
- After unscrewing the two countersunk screws at the top left instrument frame slightly lift the cover at the top of the instrument, slightly shift towards the right and lift off.
- Slightly push the FRONT MODULE from the rear to the front using little pressure.

Note: Note the connecting cables for the Option FLOPPY DISK DRIVE R&S CMU-U61 or PCMCIA INTERFACE that are still connected to the MOTHERBOARD1.

- After sliding out the FRONT MODULE disconnect the respective connecting cable for the option from the MOTHERBOARD1 as follows:
 - Option FLOPPY DISK DRIVE R&S CMU-U61: The connecting cable is a film cable.
 - Lift the locking bracket of the connector on the MOTHERBOARD1 and remove the film cable.
 - PCMCIA INTERFACE: The connecting cable consists of three ribbon cables.
 - Disconnect the three ribbon cables from the MOTHERBOARD1 connector.
- Take the FRONT MODULE completely out of the R&S CMU.

Making the LCD accessible

- Unscrew the two countersunk screws on the cover of the Option FLOPPY DISK DRIVE R&S CMU–U61 or PCMCIA INTERFACE and carefully pull out the option from the FRONT MODULE towards the front.
- Place the FRONT MODULE onto a clean surface with the aluminum panel pointing downwards.
- Unscrew the four screws on the mounting plate at the top, bottom and right and carefully swing away the mounting plate towards the rear.
- Pull off the connecting cables to the LCD, DC/AC illumination converter, keyboard membrane and spinwheel.

Note: When pulling off the connecting cables be careful with the cable connecting to the keyboard. It is a film cable which can only be disconnected after sliding up the lock of the film cable plug. Besides, be careful with the ribbon cable connecting to the spinwheel. First loosen the locking brackets of the plug.

Removing the LCD and/or DC/AC Converter

- Unscrew the two screws of the DC/AC converter shielding and pull off the plug of the connecting cable to the DC/AC converter.
- If required, unscrew the two screws of the DC/AC converter and loosen the connecting cable to the FRONT MODULE CONTROLLER.
- Remove the DC/AC converter.
- Loosen the four screws of the LCD shielding and take off the shielding.



Warning!

If there are spacing pieces under the LCD shielding, use them again for installation.

- Loosen the connecting cable to the FRONT MODULE CONTROLLER by unscrewing the two screws and remove.
- Unscrew the four screws of the LCD on the mounting plate and remove the LCD.

Installing the new LCD and/or DC/AC converter and completing the instrument

- Insert new LCD and/or DC/AC converter in the reverse order, connect all connecting cables in the correct position and replace all screws.
- Carefully plug the cable connectors to the controller board without reversing the polarities and replace the mounting plate in the reverse order.
- Replace the old Option FLOPPY DISK DRIVE R&S CMU–U61 or PCMCIA INTERFACE in the FRONT MODULE in the reverse order.

Note: Make sure to route the cables of the Option FLOPPY DISK DRIVE R&S CMU–U61 or PCMCIA INTERFACE properly, not to catch them and insert them on the MOTHERBOARD before sliding the FRONT MODULE completely into the R&S CMU.

- Complete the instrument without causing damage to the cables.

Putting into operation

- Connect the instrument to the mains and switch on.

The built-in front-module controller registers on the LCD and starts the operating software.

Replacing the Keyboard Membrane and/or Mat on the FRONT MODULE

(see chapter 5, spare part list, Current No. 161 (Keyboard Mat) / 171 (Keyboard Membrane) and explosion drawing 1090.9244.01 D sheet 3)

The keyboard membrane is the contact film for the rubber keys (mat) behind the labeling panel and the keyboard frame. For replacement proceed as follows:



Warning!

*If the old Keyboard Membrane (spare part list, Current No. 160) or the old Keyboard Membrane (spare part list, Current No. 170) have to be changed. **Both things have to be replaced.***

***Additional** have to be replaced the Keyboard frame spare part list, Current No. 181, Mounting tube spare part list, Current No. 50xx and the Labeling Panel (spare part list, Current No. 50xx).*

Opening the instrument and removing the FRONT MODULE

- Switch off the instrument, pull the mains plug and unscrew the rear-panel feet.
- Place the instrument onto the front carrying handles, push the tube upwards and take off.
- Unscrew the four screws of the front handles at the instrument frame on both sides and take off the front handles.
- Unscrew a countersunk screw (if present) at the front on the labeling panel next to the spinwheel and pull off the labeling panel towards the front.
- Unscrew two countersunk screws in the front frame at the top and at the bottom as well as two countersunk screws at the front above the AUX1/2 BNC connectors.
- Unscrew a combi screw at the top of the module support for support of the Option FLOPPY DISK DRIVE R&S CMU-U61 or PCMCIA INTERFACE.
- After unscrewing the two countersunk screws at the top left instrument frame slightly lift the cover at the top of the instrument, slightly shift towards the right and lift off.
- Slightly push the FRONT MODULE from the rear to the front using little pressure.

Note: *Note the connecting cables for the Option FLOPPY DISK DRIVE R&S CMU-U61 or PCMCIA INTERFACE that are still connected to the MOTHERBOARD1.*

- After sliding out the FRONT MODULE disconnect the respective connecting cable for the option from the MOTHERBOARD1 as follows:
 - Option FLOPPY DISK DRIVE R&S CMU-U61: The connecting cable is a film cable.
 - Lift the locking bracket of the connector on the MOTHERBOARD1 and remove the film cable.
 - PCMCIA INTERFACE: The connecting cable consists of three ribbon cables.
 - Disconnect the three ribbon cables from the MOTHERBOARD1 connector.
- Take the FRONT MODULE completely out of the R&S CMU.

Removing the membrane

- Unscrew the two countersunk screws on the cover of the Option FLOPPY DISK DRIVE R&S CMU–U61 or PCMCIA INTERFACE and carefully pull out the option from the FRONT MODULE towards the front.
- Place the FRONT MODULE onto a clean surface with the aluminum panel pointing downwards.
- Unscrew the four screws on the mounting plate at the top, bottom and right and carefully swing away the mounting plate towards the rear.
- Pull off the connecting cables to the LCD, DC/AC converter, membrane and spinwheel.
Note: *When pulling off the connecting cables be careful with the cable connecting to the keyboard. It is a film cable which can only be disconnected after sliding up the lock of the film cable plug. Besides, be careful with the ribbon cable connecting to the spinwheel. First loosen the locking brackets of the plug.*
- Place the mounting plate onto the surface with the keyboard frame pointing upwards and unscrew the 10 countersunk screws of the keyboard frame.
- Pull off the knob of the spinwheel.
- Lift off the keyboard frame as well as the mat which is now accessible.
- Lift off the membrane and pull the connecting cable through the hole of the mounting plate.

Installing the new membrane and completing the instrument

- Insert the new membrane and/or mat in the reverse order, insert the mat at the correct position (observe the labeling of the keys!) and fasten the keyboard frame with screws.
- Carefully plug the cable connectors to the controller board without reversing the polarities and replace the mounting plate in the reverse order.
- Install the old Option FLOPPY DISK DRIVE R&S CMU–U61 or PCMCIA INTERFACE in the FRONT MODULE in the reverse order.
- Install the FRONT MODULE in the R&S CMU in the reverse order.
Note: *Make sure to route the cables of the Option FLOPPY DISK DRIVE R&S CMU–U61 or PCMCIA INTERFACE properly, not to catch them and insert them on the MOTHERBOARD1 before sliding the FRONT MODULE completely into the R&S CMU.*
- Complete the instrument without causing damage to the cables.

Putting into operation

- Connect the instrument to the mains and switch on.

The built-in FRONT MODULE CONTROLLER registers on the LCD and starts the operating software.

Replacing the Labeling Panel on the FRONT MODULE

(see chapter 5, *spare part list*, *Current No. 50XX* and *explosion drawing 1100.0008.01 D sheet 2*)

The labeling panel is the outer front panel which carries the labeling of all the parts on the front side of the R&S CMU. For replacement proceed as follows:

Removing the old labeling panel

- Switch off the instrument and pull the mains plug.
- Unscrew the four screws of the front handles at the instrument frame on both sides and take off the front handles.
- Unscrew a countersunk screw (if present) at the front on the labeling panel next to the spinwheel and pull off the labeling panel towards the front.

Installing the new labeling panel and completing the instrument

- Install the new labeling panel and tighten all screws.
- Complete the instrument.

Putting into operation

- Connect the instrument to the mains and switch on.

The built-in FRONT MODULE CONTROLLER registers on the LCD and starts the operating software.

Replacing the Options FLOPPY DISK DRIVE R&S CMU-B61 or PCMCIA INTERFACE

(see chapter 5, spare part list, Current No. 1110 (FLOPPY DISK DRIVE) and 1102 (PCMCIA INTERFACE, and explosion drawing 1100.0008.01 D sheet 2)

The options FLOPPY DISK DRIVE or PCMCIA INTERFACE are fitted on the FRONT MODULE. For replacement proceed as follows:

Opening the instrument and removing the FRONT MODULE

- Switch off the instrument, pull the mains plug and unscrew the rear-panel feet.
- Place the instrument onto the front carrying handles, push the tube upwards and take off.
- Unscrew the four screws of the front handles at the instrument frame on both sides and take off the front handles.
- Unscrew a countersunk screw (if present) at the front on the labeling panel next to the spinwheel and pull off the labeling panel towards the front.
- Unscrew two countersunk screws in the front frame at the top and at the bottom as well as two countersunk screws at the front above the AUX1/2 BNC connectors.
- Unscrew a combi screw at the top of the module support for support of the Option FLOPPY DISK DRIVE R&S CMU-U61 or PCMCIA INTERFACE.
- After unscrewing the two countersunk screws at the top left instrument frame slightly lift the cover at the top of the instrument, slightly shift towards the right and lift off.
- Slightly push the FRONT MODULE from the rear to the front using little pressure.

Note: Note the connecting cables for the Option FLOPPY DISK DRIVE R&S CMU-U61 or PCMCIA INTERFACE that are still connected to the MOTHERBOARD1.

- After sliding out the FRONT MODULE disconnect the respective connecting cable for the option from the MOTHERBOARD1 as follows:
 - Option FLOPPY DISK DRIVE R&S CMU-U61: The connecting cable is a film cable.
 - Lift the locking bracket of the connector on the MOTHERBOARD1 and remove the film cable.
 - PCMCIA INTERFACE: The connecting cable consists of three ribbon cables.
 - Disconnect the three ribbon cables from the MOTHERBOARD1 connector.
- Take the FRONT MODULE completely out of the R&S CMU.

Replacing the option

- Unscrew the two countersunk screws on the cover of the Option FLOPPY DISK DRIVE R&S CMU–U61 or PCMCIA INTERFACE and carefully pull out the option from the FRONT MODULE towards the front.
- Option FLOPPY DISK DRIVE: Unscrew the countersunk screws on the frame of the FLOPPY DISK DRIVE and take out the FLOPPY DISK DRIVE.
- Install the new FLOPPY DISK DRIVE or PCMCIA INTERFACE in the FRONT MODULE in the reverse order.
- Install the FRONT MODULE in the R&S CMU in the reverse order.

Note: *Make sure to route the cables of the Option FLOPPY DISK DRIVE R&S CMU–U61 or PCMCIA INTERFACE properly, not to catch them and insert them on the MOTHERBOARD1 before sliding the FRONT MODULE completely into the R&S CMU.*

Completing the instrument and putting into operation

- Complete the instrument without causing damage to the cables.
- Connect the instrument to the mains and switch on.
- If the Option FLOPPY DISK DRIVE R&S CMU-B61 is replaced by PCMCIA INTERFACE, the following BIOS setup modification will be necessary:
 - Connect the external keyboard to the keyboard connector at the rear of the R&S CMU.
 - Switch the R&S CMU off and on.
 - Press the hardkey 'Delete' at the external keyboard to get in the BIOS setup.
 - Select *Setup* with cursor keys and confirm with *ENTER*.
 - Select 'Floppy A' with cursor keys and confirm with *ENTER*.
 - Select 'Not installed' with cursor keys and confirm with *ENTER*.
 - Quit BIOS Setup by pressing twice the hardkey *ESC* and confirm with *ENTER*. The R&S CMU starts automatically.
- If PCMCIA INTERFACE is replaced by the Option FLOPPY DISK DRIVE R&S CMU-B61, the following BIOS Setup modification will be necessary:
 - Connect the external keyboard to the keyboard connector at the rear of the R&S CMU.
 - Switch the R&S CMU off and on.
 - Press the hardkey 'Delete' at the external keyboard to get in the BIOS Setup.
 - Select *Setup* with cursor keys and confirm with *ENTER*.
 - Select 'Floppy A' with cursor keys and confirm with *ENTER*.
 - Select '1.44 MB 3 ½' with cursor keys and confirm with *ENTER*.
 - Quit BIOS Setup by pressing twice the hardkey *ESC* and confirm with *ENTER*. The R&S CMU starts automatically.

The built-in FRONT MODULE CONTROLLER registers on the LCD and starts the operating software.

Replacing the RF FRONTEND

(see chapter 5, *spare part list*, *Current No. 102X* and *explosion drawing 1100.0008.01 D sheet 2*)

The RF FRONTEND is installed at the bottom of the R&S CMU at the front right. For replacement proceed as follows:

Opening the instrument and removing the RF FRONTEND

- Switch off the instrument, pull the mains plug and unscrew the rear-panel feet.
- Place the instrument onto the front carrying handles, push the tube upwards and take off.
- Place the instrument upside down to make the bottom accessible.
- Pull off the ribbon cable to the MOTHERBOARD on the RF FRONTEND. Completely unscrew RF SMA coax cables to the RXTX BOARD1 (if present, also those to the RXTX2 BOARD and RXTXAUX1/2 connectors) on the RF FRONTEND and RXTX BOARD1 using a special wrench*.
- Unscrew the two countersunk screws at the bottom front of the front frame and one countersunk screw on the side panel of the R&S CMU for supporting the RF FRONTEND.
- Pull the RF FRONTEND approx. 20 mm towards the rear and then swing towards the bottom.

Installing the new RF FRONTEND MODULE and completing the instrument

- Insert the RF FRONTEND into the instrument in the reverse order and connect all cables.
- Complete the instrument without causing damage to the cables.
- Connect the instrument to the mains and switch on.

Automatic module data adjustment

- During startup observe the display.
- When three BEEPs can be heard, press the *MENU SELECT* key.
The version manager is started (see also chapter 4, *Firmware update*). The display includes the menu item *FIRMWARE UPDATE AFTER BOARD CHANGE*.
- Press the softkey to the left of the above mentioned menu item.
The automatic module data adjustment is performed under software control, firmware updates for microprocessors and programmable devices being performed as well. This may take a few minutes.

After the adjustment has been terminated, the operating software starts automatically and the R&S CMU is ready for use and complies with the specifications, except for the level accuracy.

In order to achieve the level accuracy described in the data sheet, a so-called path error data record is necessary.

To this end, the R&S CMU must be measured using the test system ACS 100 (see chapter 1, *Performance Test*).

* available in CMU-Service Kit CMU-Z3 (1100.7690.02)

Replacing the REFERENCE BOARD

(see chapter 5, *spare part list*, *Current No. 1100* and *explosion drawing 1100.0008.01 D sheet 2*)

The REFERENCE BOARD is installed at the front right top of the R&S CMU as plug-in module in the cage. For replacement proceed as follows:

Opening the instrument and removing the REFERENCE BOARD

- Switch off the instrument, pull the mains plug and unscrew the rear-panel feet.
- Place the instrument onto the front carrying handles, push the tube upwards and take off.
- Unscrew the combi screw from the locking bracket of the module in the vicinity of the instrument fan and fold up.
- Pull off all MMCX plug-in cables (using a pull-out tool*) from the top of the REFERENCE BOARD and pull out the module towards the top with the help of the locking bracket.

Installing the new REFERENCE BOARD and completing the instrument

- Insert the new REFERENCE BOARD in the instrument in the reverse order and connect all MMCX plug-in cables.
- Perform manual adjustment +5 VDC reference voltage and TCXO adjustment as described in chapter 2.
- Complete the instrument without causing damage to the cables.
- Connect the instrument to the mains and switch on.

Automatic module data adjustment

- During startup observe the display.
- When three BEEPs can be heard, press the *MENU SELECT* key.
The version manager is started (see also chapter 4, *Firmware update*). The display includes the menu item *FIRMWARE UPDATE AFTER BOARD CHANGE*.
- Press the softkey to the left of the above mentioned menu item.
The automatic module data adjustment is performed under software control, firmware updates for microprocessors and programmable devices being performed as well. This may take a few minutes.

After the adjustment has been terminated, the operating software starts automatically and the R&S CMU is ready for use and complies with the specifications.

* available in CMU-Service Kit CMU-Z3 (1100.7690.02)

Replacing the RXTX BOARD1

(see chapter 5, *spare part list*, *Current No. 280X* and *explosion drawing 1100.0008.01 D sheet 2*)

The RXTX BOARD1 is installed in the module support as plug-in module. For replacement proceed as follows:

Opening the instrument and removing the RXTX BOARD1

- Switch off the instrument, pull the mains plug and unscrew the rear-panel feet.
- Place the instrument onto the front carrying handles, push the tube upwards and take off.
- After unscrewing the two countersunk screws at the top left instrument frame, slightly lift the cover at the top of the instrument, slightly shift towards the right and lift off.
- Place the instrument to the left side and unscrew the two RF SMA coax cables at the bottom of the RXTX BOARD1 using a special wrench*. Likewise pull off the MMCX plug-in cable (using a pull-out tool*) from the bottom.
- Pull off all MMCX plug-in cables from the top of the RXTX1 BOARD and pull out the board using the two levers on both sides.

Installing the new RXTX BOARD1 and completing the instrument

- Insert the new RXTX BOARD1 into the instrument in the reverse order and carefully connect all the MMCX plug-in and RF SMA coax cables.
- Complete the instrument without causing damage to the cables.
- Connect the instrument to the mains and switch on.

Automatic module data adjustment

- During startup observe the display.
- When three BEEPs can be heard, press the *MENU SELECT* key.
The version manager is started (see also chapter 4, *Firmware update*). The display includes the menu item *FIRMWARE UPDATE AFTER BOARD CHANGE*.
- Press the softkey to the left of the above mentioned menu item.
The automatic module data adjustment is performed under software control, firmware updates for microprocessors and programmable devices being performed as well. This may take a few minutes.

After the adjustment has been terminated, the operating software starts automatically and the R&S CMU is ready for use and complies with the specifications, except for the high-precision level accuracy.

In order to achieve the level accuracy as described in the data sheet, a so-called path error data record is necessary.

To this end, the R&S CMU must be measured using the test system ACS 100 (see chapter 1, *Performance Test*).

* available in CMU-Service Kit CMU-Z3 (1100.7690.02)

Replacing the TR-CORRECTION MODULE in the RXTX BOARD1

(see chapter 5, *spare part list*, *Current No. 320* and *explosion drawing 1135.6925.01 D 3*)

The TR-CORRECTION MODULE is incorporated in the RXTX1 BOARD as sandwich module. For replacement proceed as follows:

Opening the instrument and removing the TR-CORRECTION MODULE

- Switch off the instrument, pull the mains plug and unscrew the rear-panel feet.
- Place the instrument onto the front carrying handles, push the tube upwards and take off.
- After unscrewing the two countersunk screws at the top left instrument frame, slightly lift the cover at the instrument top, slightly push to the right and lift off.
- Place the instrument to the left side and unscrew the two RF SMA coax cables at the bottom of the RXTX BOARD1 using a special wrench. Likewise, pull off the MMCX plug-in cable at the bottom.
- Pull off all the MMCX plug-in cables (using a pull-out tool*) from the top of the RXTX BOARD1 and pull off the module towards the top using the two levers on the right and left.
- Unscrew one screw of each cooling plate, pull off the cooling plates towards the side and then unscrew all screws of the RXTX aluminum cover shells. Then the cover shells of the top and bottom can be removed.
- Pull off the sandwich module TR-CORRECTION MODULE (using a pull-out tool*) from the RXTX BOARD1.

Installing the new TR-CORRECTION BOARD and completing the instrument

- Insert the new TR-CORRECTION MODULE.
- Reinsert the cover shells in the reverse order and fasten with screws. Attach the cooling plates again.
- Insert the RXTX BOARD1 into the instrument in the reverse order and carefully connect all the MMCX plug-in cables and RF-SMA coax cables.
- Complete the instrument without causing damage to the cables.
- Connect the instrument to the mains and switch on.

Automatic module data adjustment

- During startup observe the display.
- When three BEEPs can be heard, press the *MENU SELECT* key.
The version manager is started (see also chapter 4, *Firmware update*). The display includes the menu item *FIRMWARE UPDATE AFTER BOARD CHANGE*.
- Press the softkey to the left of the above mentioned menu item.
The automatic module data adjustment is performed under software control, firmware updates for microprocessors and programmable devices being performed as well. This may take a few minutes.

After the adjustment has been terminated, the operating software starts automatically and the R&S CMU is ready for use and complies with the specifications, except for the high-precision level accuracy. In order to achieve the level accuracy as described in the data sheet, a so-called path error data record is necessary.

To this end, the R&S CMU must be measured using the test system ACS 100 (see chapter 1, *Performance Test*).

* available in CMU-Service Kit CMU-Z3 (1100.7690.02)

Replacing the DIGITAL BOARD

(see chapter 5, *spare part list*, *Current No. 70X* and *explosion drawing 1100.0008.01 D sheet 2*)

The DIGITAL BOARD is incorporated in the module support as plug-in module. For replacement proceed as follows:

Opening the instrument and removing the DIGITAL BOARD

- Switch off the instrument, pull the mains plug and unscrew the rear-panel feet.
- Place the instrument onto the front carrying handles, push the tube upwards and take off.
- After unscrewing the two countersunk screws at the top left instrument frame, slightly lift the cover at the instrument top, slightly push to the right and lift off.
- Pull off all the MMCX plug-in cables (using a pull-out tool*) from the top of the DIGITAL BOARD and pull off the module towards the top using the two levers on the right and left.

Installing the new DIGITAL BOARD and completing the instrument

- Insert the new DIGITAL BOARD into the instrument in the reverse order and connect all the MMCX plug-in cables.
- Complete the instrument without causing damage to the cables.
- Connect the instrument to the mains and switch on.

Automatic module data adjustment

- During startup observe the display.
- When three BEEPs can be heard, press the *MENU SELECT* key.
The version manager is started (see also chapter 4, *Firmware update*). The display includes the menu item *FIRMWARE UPDATE AFTER BOARD CHANGE*.
- Press the softkey to the left of the above mentioned menu item.
The automatic module data adjustment is performed under software control, firmware updates for microprocessors and programmable devices being performed as well. This may take a few minutes.

After the adjustment has been terminated, the operating software starts automatically and the R&S CMU is ready for use and complies with the specifications, except for the high-precision level accuracy. In order to achieve the level accuracy as described in the data sheet, a so-called path error data record is necessary.

To this end, the R&S CMU must be measured using the test system ACS 100 (see chapter 1, *Performance Test*).

* available in CMU-Service Kit CMU-Z3 (1100.7690.02)

Replacing the MODULES: ADC MODULE1, DDC MODULE1, TXDSP MODULE1, AUC MODULE1 in the DIGITAL BOARD

(see chapter 5, *spare part list*, *Current No. 72X (ADC MODULE1)*, *Current No. 71X (DDC MODULE1)*, *Current No. 75X (TXDSP MODULE1)*, *Current No. 760 (AUC MODULE1)* and *explosion drawing 1100.1940.01 D sheet 2*)

The sandwich modules ADC MODULE1, DDC MODULE1, TXDSP MODULE1 and AUC MODULE1 are installed in the DIGITAL BOARD as plug-in modules. For replacement proceed as follows:

Opening the instrument and removing the modules

- Switch off the instrument, pull the mains plug and unscrew the rear-panel feet.
- Place the instrument onto the front carrying handles, push the tube upwards and take off.
- After unscrewing the two countersunk screws at the top left instrument frame, slightly lift the cover at the instrument top, slightly push to the right and lift off.
- Pull off all the MMCX plug-in cables (using a pull-out tool*) from the top of the DIGITAL BOARD and pull off the module towards the top using the two levers on the right and left.
- By Digital Board 1100.1791.0X (*spare part list*, *Current No. 700 or 701*) remove the cover of the higher HVC side (B-side) by loosening the cover screws.
- By Digital Board 1100.1940.0X (*spare part list*, *Current No. 702 or 703*) remove the covers by loosening the cover screws.
- Carefully lever out the respective sandwich module (using a pull-out tool*) in the case of the ADC MODULE loosen the two or threefixing screws before.

Installing the new sandwich module and completing the instrument

- Replace by a new module.

Caution!

Take care to insert the module at the correct position.



The heat conducting mats have to be stuck to the components of the modules (see chapter 5, drawing 1100.1940.01 D sheet 2).

- Insert the DIGITAL BOARD into the instrument in the reverse order and connect all the MMCX plug-in cables.
- Complete the instrument without causing damage to the cables.
- Connect the instrument to the mains and switch on.

* available in CMU-Service Kit CMU-Z3 (1100.7690.02)

Automatic module data adjustment

- During startup observe the display.
- When three BEEPs can be heard, press the *MENU SELECT* key.
The version manager is started (see also chapter 4, *Firmware update*). The display includes the menu item *FIRMWARE UPDATE AFTER BOARD CHANGE*.
- Press the softkey to the left of the above mentioned menu item.
The automatic module data adjustment is performed under software control, firmware updates for microprocessors and programmable devices being performed as well. This may take a few minutes.

After the adjustment has been terminated, the operating software starts automatically and the R&S CMU is ready for use and complies with the specifications, except for the high-precision level accuracy. In order to achieve the level accuracy as described in the data sheet, a so-called path error data record is necessary.

To this end, the R&S CMU must be measured using the test system ACS 100 (see chapter 1, *Performance Test*).

Replacing the Option OCXO REFERENCE OSC. R&S CMU-B11 or R&S CMU-B12

(see chapter 5, spare part list, *Current No. 2205 (OCXO REFERENCE OSC. CMU-B11), 2206 (OCXO REFERENCE OSC. CMU-B12) and explosion drawing 1100.0008.01 D sheet 2*)

The Option OCXO REFERENCE OSC. is fitted at the right side panel below the instrument fan in the R&S CMU. For replacement proceed as follows:

Opening the instrument and removing the OPTION OCXO REFERENCE OSC.

- Switch off the instrument, pull the mains plug and unscrew the rear-panel feet.
- Place the instrument onto the front carrying handles, push the tube upwards and take off.
- Place the instrument onto the left side, locate the OPTION OCXO (*see chapter 5, explosion drawing 1100.0008.01 D sheet 2*) and unscrew the two combi screws on the module support and one combi screw on the MOTHERBOARD1.
- Pull off OPTION OCXO REFERENCE OSC. from the MOTHERBOARD1 connector, slightly tilt and swing out towards the bottom.

Installing the new OPTION OCXO REFERENCE OSC. and completing the instrument

- Install the new OPTION OCXO REFERENCE OSC. in the reverse order. Tighten the three combi screws again.

Note: *Make sure that the 10-pin connector to the MOTHERBOARD is inserted correctly.*

- Complete the instrument without causing damage to the cables.

Manual OCXO adjustment

- Connect the instrument to the mains and switch on.
- Check the frequency accuracy and, if necessary, perform manual OCXO adjustment as described in chapter 2.

Replacing the Option UNIVERSAL SIGNALLING UNIT R&S CMU-B21 Var02

(see chapter 5, spare part list, Current No. 240X and explosion drawing 1100.0008.01 D sheet 2)

The OPTION UNIV. SIGN. UNIT is installed in the module support as plug-in module. For replacement proceed as follows:

Opening the instrument and removing the OPTION UNIV. SIGN. UNIT

- Switch off the instrument, pull the mains plug and unscrew the rear-panel feet.
- Place the instrument onto the front carrying handles, push the tube upwards and take off.
- After unscrewing the two countersunk screws at the top left instrument frame slightly lift the cover at the top of the instrument, slightly shift towards the right and lift off.
- Take out the module using the two levers on the right and left.

Installing the new OPTION UNIV. SIGN. UNIT and completing the instrument

- Insert the new OPTION UNIV. SIGN. UNIT into the instrument in the reverse order.
- Complete the instrument without causing damage to the cables.
- Connect the instrument to the mains and switch on.

Automatic module data adjustment

- During startup observe the display.
- When three BEEPs can be heard, press the *MENU SELECT* key.
The version manager is started (see also chapter 4, *Firmware update*). The display includes the menu item *FIRMWARE UPDATE AFTER BOARD CHANGE*.
- Press the softkey to the left of the above mentioned menu item.
The automatic module data adjustment is performed under software control, firmware updates for microprocessors and programmable devices being performed as well. This may take a few minutes.

After the adjustment has been terminated, the operating software starts automatically and the R&S CMU is ready for use and complies with the specifications.

Replacing the MODULES: DSP MODULE0/1, IQOUT MODULE, BLUETOOTH MODULE, SPEECH CODEC R&S CMU-B52 (INCLUDES DSP MODULE3) in the UNIV. SIGN. UNIT Var02

(see chapter 5, spare part list, Current No. 243X (DSP MODULE), 2440 (SPEECH CODEC), 2420 (I/Q OUT MODULE, 2450 (BLUETOOTH MODULE), and explosion drawing 1100.5216.01 D sheet 2)

The sandwich modules DSP MODULE0, DSP MODULE1, IQOUT MODULE, BLUETOOTH MODULE and OPTION SPEECH CODEC R&S CMU-B52 (includes DSP MODULE3) are installed in the UNIV. SIGN. UNIT as plug-in modules. For replacement proceed as follows:

Opening the instrument and removing the modules

- Switch off the instrument, pull the mains plug and unscrew the rear-panel feet.
- Place the instrument onto the front carrying handles, push the tube upwards and take off.
- After unscrewing the two countersunk screws at the top left instrument frame slightly lift the cover at the top of the instrument, slightly shift towards the right and lift off.
- Take out the module using the two levers on the right and left.
- Take off the cover on the higher side (B-side) by loosening the cover screws.
- Carefully lever out the respective sandwich module (using a pull-out tool*) (see chapter 5, drawing 1100.5216.01 D sheet 2).

Installing the new sandwich module and completing the instrument

- Replace by new module.

Caution!



Take care to insert the respective module (DSP MODULE0 and DSP MODULE1 modules are of the same design) with the correct polarity (see chapter 5, drawing 1100.5216.01 sheet 2).

- Replace the cover and fasten with screws.
- Insert the Option UNIV. SIGN. UNIT into the instrument in the reverse order.
- Complete the instrument without causing damage to the cables.
- Connect the instrument to the mains and switch on.

* available in CMU-Service Kit CMU-Z3 (1100.7690.02)

Automatic module data adjustment

- During startup observe the display.
- When three BEEPs can be heard, press the *MENU SELECT* key.
The version manager is started (see also chapter 4, *Firmware update*). The display includes the menu item *FIRMWARE UPDATE AFTER BOARD CHANGE*.
- Press the softkey to the left of the above mentioned menu item.
The automatic module data adjustment is performed under software control, firmware updates for microprocessors and programmable devices being performed as well. This may take a few minutes.

After the adjustment has been terminated, the operating software starts automatically and the R&S CMU is ready for use and complies with the specifications.

Replacing the Option UNIVERSAL SIGNALLING UNIT CMU-B21 Var14/54

(see chapter 5, spare part list, *Current No. 250X and explosion drawing 1100.0008.01 D sheet 2*)

The OPTION UNIV. SIGN. UNIT is installed in the module support as plug-in module. For replacement proceed as follows:

Opening the instrument and removing the OPTION UNIV. SIGN. UNIT

- Switch off the instrument, pull the mains plug and unscrew the rear-panel feet.
- Place the instrument onto the front carrying handles, push the tube upwards and take off.
- After unscrewing the two countersunk screws at the top left instrument frame slightly lift the cover at the top of the instrument, slightly shift towards the right and lift off.
- Take out the module using the two levers on the right and left.

Caution: module could be fitted together with the next module and have to take out together with this (if available: WCDMA L1COPRO CMU-B66/68/76/78).

Installing the new OPTION UNIV. SIGN. UNIT and completing the instrument

- Insert the new OPTION UNIV. SIGN. UNIT into the instrument in the reverse order.
- Complete the instrument without causing damage to the cables.
- Connect the instrument to the mains and switch on.

Automatic module data adjustment

- During startup observe the display.
- When three BEEPs can be heard, press the MENU SELECT key.
The version manager is started (see also chapter 4, Firmware update). The display includes the menu item *FIRMWARE UPDATE AFTER BOARD CHANGE*.
- Press the softkey to the left of the above mentioned menu item.
The automatic module data adjustment is performed under software control, firmware updates for microprocessors and programmable devices being performed as well. This may take a few minutes.

After the adjustment has been terminated, the operating software starts automatically and the R&S CMU is ready for use and complies with the specifications.

Replacing the MODULES: SPEECH CODEC, BLUETOOTH MODULE, MC 68K, DSP MODULE, POWER PC MODULE, OPTION SPEECH CODEC CMU-B52VAR 14 in the UNIV. SIGN. UNIT Var14/54

(see chapter 5, spare part list, *Current No. 2520 (SPEECH CODEC), 2530 (BLUETOOTH MODULE), 2540 (MC 68K), 2550 (DSP MODULE), 256X POWER PC MODULE*) and explosion drawing 1100.4497.01 D sheet 2)

The sandwich modules SPEECH CODEC, BLUETOOTH MODULE, MC 68K, DSP MODULE, POWER PC MODULE are installed in the UNIV. SIGN. UNIT as plug-in modules. For replacement proceed as follows:

Opening the instrument and removing the modules

- Switch off the instrument, pull the mains plug and unscrew the rear-panel feet.
- Place the instrument onto the front carrying handles, push the tube upwards and take off.
- After unscrewing the two countersunk screws at the top left instrument frame slightly lift the cover at the top of the instrument, slightly shift towards the right and lift off.
- Take out the module using the two levers on the right and left.

Caution: module could be fitted together with the next module and have to take out together with this (if available: WCDMA L1COPRO CMU-B66/68/76/78).

- Take off the covers by loosening the cover screws.
- Carefully loosening the screws of the respective sandwich module (using a torque screwdriver tool*) and take out the module (see chapter 5, drawing 1100.4497.01 D sheet 2).

Installing the new sandwich module and completing the instrument

- Replace by new module in reverse order.

Caution!



Take care to use the torque screwdriver tool to fit the screws with the right torque.*

Take care to insert the respective module with the correct polarity (see chapter 5, drawing 1100.4497.01 sheet 2).

- Replace the covers and fasten with screws.
- Insert the Option UNIV. SIGN. UNIT into the instrument in the reverse order.
- Complete the instrument without causing damage to the cables.
- Connect the instrument to the mains and switch on.

* available in CMU-Service Kit CMU-Z3 (1100.7690.02)

* available in CMU-Service Kit CMU-Z3 (1100.7690.02)

Automatic module data adjustment

- During startup observe the display.
- When three BEEPs can be heard, press the MENU SELECT key.
The version manager is started (see also chapter 4, Firmware update). The display includes the menu item *FIRMWARE UPDATE AFTER BOARD CHANGE*.
- Press the softkey to the left of the above mentioned menu item.
The automatic module data adjustment is performed under software control, firmware updates for microprocessors and programmable devices being performed as well. This may take a few minutes.

After the adjustment has been terminated, the operating software starts automatically and the R&S CMU is ready for use and complies with the specifications.

Replacing the Option WCDMA L1COPRO CMU-B66/68/76/78

(see chapter 5, *spare part list*, *Current No. 280X* and *explosion drawing 1100.0008.01 D sheet 2*)

The WCDMA L1COPRO is installed in the module support as plug-in module. For replacement proceed as follows:

Opening the instrument and removing the OPTION WCDMA L1COPRO

- Switch off the instrument, pull the mains plug and unscrew the rear-panel feet.
- Place the instrument onto the front carrying handles, push the tube upwards and take off.
- After unscrewing the two countersunk screws at the top left instrument frame slightly lift the cover at the top of the instrument, slightly shift towards the right and lift off.
- Pull off the powersupply cable from the downside of the WCDMA L1COPRO
- Pull off all the MMCX plug-in cables (using a pull-out tool*) from the top of the WCDMA L1COPRO and pull off the module towards the top using the two levers on the right and left.

Caution: module could be fitted together with the next module and have to take out together with this (if available: UNIV.SIGN.UNIT).

Installing the new OPTION UNIV. SIGN. UNIT and completing the instrument

- Insert the new option WCDMA L1COPRO into the instrument in the reverse order and connect all the MMCX plug-in cables and the powersupply cable.
- Complete the instrument without causing damage to the cables.
- Connect the instrument to the mains and switch on.

Automatic module data adjustment

- During startup observe the display.
- When three BEEPs can be heard, press the MENU SELECT key.
The version manager is started (see also chapter 4, *Firmware update*). The display includes the menu item *FIRMWARE UPDATE AFTER BOARD CHANGE*.

* available in CMU-Service Kit CMU-Z3 (1100.7690.02)

- Press the softkey to the left of the above mentioned menu item.
The automatic module data adjustment is performed under software control, firmware updates for microprocessors and programmable devices being performed as well. This may take a few minutes.

After the adjustment has been terminated, the operating software starts automatically and the R&S CMU is ready for use and complies with the specifications, except for the high-precision level accuracy.

In order to achieve the level accuracy as described in the data sheet, a so-called path error data record is necessary.

To this end, the R&S CMU must be measured using the test system ACS 100 (see chapter 1, *Performance Test*).

Replacing the MODULES: WCDMATX MODULE, TX-FEC MODULE, WDDC MODULE, RX-FEC MODULE , in the WCDMA L1COPRO CMU-B66/68/76/78

(see chapter 5, *spare part list*, *Current No. 282X (WCDMATX MODULE)*, *2830+2831 (TX-FEC MODULE)*, *2840 (WDDC MODULE)*, *2832+2833 (RX-FEC MODULE)* and *explosion drawing 1100.5041.01 D sheet 3/4*)

The sandwich modules *WCDMATX MODULE*, *TX-FEC MODULE*, *WDDC MODULE*, *RX-FEC MODULE*) are installed in the WCDMA L1COPRO as plug-in modules. For replacement proceed as follows:

Opening the instrument and removing the modules

- Switch off the instrument, pull the mains plug and unscrew the rear-panel feet.
- Place the instrument onto the front carrying handles, push the tube upwards and take off.
- After unscrewing the two countersunk screws at the top left instrument frame slightly lift the cover at the top of the instrument, slightly shift towards the right and lift off.
- Pull off the powersupply cable from the downside of the WCDMA L1COPRO
- Pull off all the MMCX plug-in cables (using a pull-out tool*) from the top of the WCDMA L1COPRO and pull off the module towards the top using the two levers on the right and left.

Caution: module could be fitted together with the next module and have to take out together with this (if available: UNIV.SIGN.UNIT).

- Take off the covers by loosening the cover screws.
- Carefully loosening the screws of the respective sandwich module (using a torque screwdriver tool*) and take out the module (see chapter 5, drawing 1100.5041.01 D sheet 3/4).

* available in CMU-Service Kit CMU-Z3 (1100.7690.02)

* available in CMU-Service Kit CMU-Z3 (1100.7690.02)

Installing the new sandwich module and completing the instrument

- Replace by new module in reverse order.

Caution!



Take care to use the torque screwdriver tool to fit the screws with the right torque.*

Take care to insert the respective module with the correct polarity (see chapter 5, drawing 1100.5041.01 sheet 3/4).

- Replace the covers and fasten with screws.
- Insert the Option WCDMA L1COPRO into the instrument in the reverse order and connect all the MMCX plug-in cables and the powersupply cable.
- Complete the instrument without causing damage to the cables.
- Connect the instrument to the mains and switch on.

Automatic module data adjustment

- During startup observe the display.
- When three BEEPs can be heard, press the MENU SELECT key.
The version manager is started (see also chapter 4, *Firmware update*). The display includes the menu item *FIRMWARE UPDATE AFTER BOARD CHANGE*.
- Press the softkey to the left of the above mentioned menu item.
The automatic module data adjustment is performed under software control, firmware updates for microprocessors and programmable devices being performed as well. This may take a few minutes.

After the adjustment has been terminated, the operating software starts automatically and the R&S CMU is ready for use and complies with the specifications, except for the high-precision level accuracy. In order to achieve the level accuracy as described in the data sheet, a so-called path error data record is necessary.

To this end, the R&S CMU must be measured using the test system ACS 100 (see chapter 1, *Performance Test*).

Replacing the Option CDMA2000 Signaling Unit CMU-B83 Var12

(see chapter 5, spare part list, Current No. 330X and explosion drawing 1100.0008.01 D sheet 2)

The OPTION CDMA2000 SIGNALING UNIT is installed in the module support as plug-in module. For replacement proceed as follows:

Opening the instrument and removing the OPTION CDMA2000 SIGNALING UNIT

- Switch off the instrument, pull the mains plug and unscrew the rear-panel feet.
- Place the instrument onto the front carrying handles, push the tube upwards and take off.

* available in CMU-Service Kit CMU-Z3 (1100.7690.02)

- After unscrewing the two countersunk screws at the top left instrument frame slightly lift the cover at the top of the instrument, slightly shift towards the right and lift off.
- Pull off all cables (if fitted) from the top of the OPTION CDMA2000 SIGNALING UNIT.
- Take out the module using the two levers on the right and left.

Installing the new OPTION CDMA2000 SIGNALING UNIT and completing the instrument

- Insert the new OPTION CDMA2000 SIGNALING UNIT into the instrument in the reverse order and connect all the cables on the top.
- Complete the instrument without causing damage to the cables.
- Connect the instrument to the mains and switch on.

Automatic module data adjustment

- During startup observe the display.
- When three BEEPs can be heard, press the MENU SELECT key.
The version manager is started (see also chapter 4, Firmware update). The display includes the menu item *FIRMWARE UPDATE AFTER BOARD CHANGE*.
- Press the softkey to the left of the above mentioned menu item.
The automatic module data adjustment is performed under software control, firmware updates for microprocessors and programmable devices being performed as well. This may take a few minutes.

After the adjustment has been terminated, the operating software starts automatically and the R&S CMU is ready for use and complies with the specifications.

Replacing the MODULES: ACCESS MODULE CMU-B82, SPEECH CODEC MODULE CMU-B85, HDR MODULE CMU-B88 in the CDMA2000 Signaling Unit CMU-B83 Var12

(see chapter 5, *spare part list*, *Current No. 3310* (ACCESS MODULE), *332X* (SPEECH CODEC MODULE) *3325* (HDR MODULE) and *explosion drawing 1150.0301.01 D sheet 2*)

The sandwich modules ACCESS MODULE, SPEECH CODEC MODULE, HDR MODULE are installed in the CDMA2000 SIGNALING UNIT as plug-in modules. For replacement proceed as follows:

Opening the instrument and removing the modules

- Switch off the instrument, pull the mains plug and unscrew the rear-panel feet.
- Place the instrument onto the front carrying handles, push the tube upwards and take off.
- After unscrewing the two countersunk screws at the top left instrument frame slightly lift the cover at the top of the instrument, slightly shift towards the right and lift off.
- Pull off all cables (if fitted) from the top of the OPTION CDMA2000 SIGNALING UNIT.
- Pull off the module towards the top using the two levers on the right and left.
- Take off the covers by loosening the cover screws.
- Carefully loosening the screws of the respective sandwich module (using a torque screwdriver tool*) and take out the module (see chapter 5, *drawing 1150.0301.01 D sheet 2*).

Installing the new sandwich module and completing the instrument

* available in CMU-Service Kit CMU-Z3 (1100.7690.02)

- Replace by new module in reverse order .

Caution!

Take care to use the torque screwdriver tool to fit the screws with the right torque.*

Take care to insert the respective module with the correct polarity (see chapter 5, drawing 1150.0301.01 sheet 2).

- Replace the covers and fasten with screws.
- Insert the Option CDMA2000 SIGNALING UNIT into the instrument in the reverse order and connect all the cables on the top.
- Complete the instrument without causing damage to the cables.
- Connect the instrument to the mains and switch on.

Automatic module data adjustment

- During startup observe the display.
- When three BEEPs can be heard, press the MENU SELECT key.
The version manager is started (see also chapter 4, *Firmware update*). The display includes the menu item *FIRMWARE UPDATE AFTER BOARD CHANGE*.
- Press the softkey to the left of the above mentioned menu item.
The automatic module data adjustment is performed under software control, firmware updates for microprocessors and programmable devices being performed as well. This may take a few minutes.

After the adjustment has been terminated, the operating software starts automatically and the R&S CMU is ready for use and complies with the specifications.

Replacing the Option CDMA2000 Signaling Unit CMU-B83 Var22

(see chapter 5, *spare part list*, *Current No. 3330* and *explosion drawing 1100.0008.01 D sheet 2*)

The OPTION CDMA2000 SIGNALING UNIT is installed in the module support as plug-in module. For replacement proceed as follows:

Opening the instrument and removing the OPTION CDMA2000 SIGNALING UNIT

- Switch off the instrument, pull the mains plug and unscrew the rear-panel feet.
- Place the instrument onto the front carrying handles, push the tube upwards and take off.
- After unscrewing the two countersunk screws at the top left instrument frame slightly lift the cover at the top of the instrument, slightly shift towards the right and lift off.
- Pull off all cables (if fitted) from the top of the OPTION CDMA2000 SIGNALING UNIT.
- Take out the module using the two levers on the right and left.

* available in CMU-Service Kit CMU-Z3 (1100.7690.02)

Installing the new OPTION CDMA2000 SIGNALING UNIT and completing the instrument

- Insert the new OPTION CDMA2000 SIGNALING UNIT into the instrument in the reverse order and connect all the cables on the top.
- Complete the instrument without causing damage to the cables.
- Connect the instrument to the mains and switch on.

Automatic module data adjustment

- During startup observe the display.
- When three BEEPs can be heard, press the MENU SELECT key.
The version manager is started (see also chapter 4, *Firmware update*). The display includes the menu item *FIRMWARE UPDATE AFTER BOARD CHANGE*.
- Press the softkey to the left of the above mentioned menu item.
The automatic module data adjustment is performed under software control, firmware updates for microprocessors and programmable devices being performed as well. This may take a few minutes.

After the adjustment has been terminated, the operating software starts automatically and the R&S CMU is ready for use and complies with the specifications.

Replacing the MODULES: 1xEV-DO MODULE CMU-B89, SPEECH CODEC MODULE CMU-B85 VAR22, POWER QUICC3 MODULE in the CDMA2000 Signaling Unit CMU-B83 Var22

(see chapter 5, *spare part list*, *Current No. 3360* (1xEV-DO MODULE), *3340* (SPEECH CODEC MODULE) *3350* (POWER QUICC3 MODULE) and *explosion drawing 1150.0301 D sheet 2*)

The sandwich modules 1xEV-DO MODULE, SPEECH CODEC MODULE, POWER QUICC3 MODULE are installed in the CDMA2000 SIGNALING UNIT as plug-in modules. For replacement proceed as follows:

Opening the instrument and removing the modules

- Switch off the instrument, pull the mains plug and unscrew the rear-panel feet.
- Place the instrument onto the front carrying handles, push the tube upwards and take off.
- After unscrewing the two countersunk screws at the top left instrument frame slightly lift the cover at the top of the instrument, slightly shift towards the right and lift off.
- Pull off all cables (if fitted) from the top of the OPTION CDMA2000 SIGNALING UNIT.
- Pull off the module towards the top using the two levers on the right and left.
- Take off the covers by loosening the cover screws.
- Carefully loosening the screws of the respective sandwich module (using a torque screwdriver tool*) and take out the module (see chapter 5, *drawing 1150.0301.01 D sheet 2*).

* available in CMU-Service Kit CMU-Z3 (1100.7690.02)

Installing the new sandwich module and completing the instrument

- Replace by new module in reverse order.

Caution!



Take care to use the torque screwdriver tool to fit the screws with the right torque.*

Take care to insert the respective module with the correct polarity (see chapter 5, drawing 1150.0301.01 sheet 2).

- Replace the covers and fasten with screws.
- Insert the Option CDMA2000 SIGNALING UNIT into the instrument in the reverse order and connect all the cables on the top.
- Complete the instrument without causing damage to the cables.
- Connect the instrument to the mains and switch on.

Automatic module data adjustment

- During startup observe the display.
-
- When three BEEPs can be heard, press the MENU SELECT key.
- The version manager is started (see also chapter 4, Firmware update). The display includes the menu item *FIRMWARE UPDATE AFTER BOARD CHANGE*.
- Press the softkey to the left of the above mentioned menu item.
- The automatic module data adjustment is performed under software control, firmware updates for microprocessors and programmable devices being performed as well. This may take a few minutes.
-
- After the adjustment has been terminated, the operating software starts automatically and the R&S CMU is ready for use and complies with the specifications.

* available in CMU-Service Kit CMU-Z3 (1100.7690.02)

Replacing the Option AUDIO-GEN. + ANA. CMU-B41

(see chapter 5, spare part list, Current No. 2600 and explosion drawing 1100.0008.01 D sheet 2) and 1100.2800.01 D sheet 3)

The Option AUDIO-GEN. + ANA. is installed at the front right top of the R&S CMU as plug-in module in the cage. For replacement proceed as follows:

Opening the instrument and removing the Option AUDIO-GEN. + ANA.

- Switch off the instrument, pull the mains plug and unscrew the rear-panel feet.
- Place the instrument onto the front carrying handles, push the tube upwards and take off.
- Unscrew the combi screw from the locking bracket of the module in the vicinity of the instrument fan and fold up.
- Pull off all MMCX plug-in cables (using a pull-out tool*) from the top of the Option AUDIO-GEN. + ANA. and pull out the module towards the top with the help of the locking bracket.

Installing the new Option AUDIO-GEN. + ANA. and completing the instrument

- Insert the new Option AUDIO-GEN. + ANA. in the instrument in the reverse order and connect all MMCX plug-in cables.
- Complete the instrument without causing damage to the cables.
- Connect the instrument to the mains and switch on.

Automatic module data adjustment

- During startup observe the display.
- When three BEEPs can be heard, press the *MENU SELECT* key.
The version manager is started (see also chapter 4, *Firmware update*). The display includes the menu item *FIRMWARE UPDATE AFTER BOARD CHANGE*.
- Press the softkey to the left of the above mentioned menu item.
The automatic module data adjustment is performed under software control, firmware updates for microprocessors and programmable devices being performed as well. This may take a few minutes.

After the adjustment has been terminated, the operating software starts automatically and the R&S CMU is ready for use and complies with the specifications.

* available in CMU-Service Kit CMU-Z3 (1100.7690.02)

Replacing the POWER SUPPLY

(see chapter 5, spare part list, Current No. 1000+1010 and explosion drawing 1100.0008.01 D sheet 2)

The POWER SUPPLY is fitted at the rear of the instrument frame of the R&S CMU. For replacement proceed as follows:

Removing the POWER SUPPLY

- Switch off the instrument and pull the mains plug.
- Unscrew the ten screws at the rear of the POWER SUPPLY. Pull out the power supply approx. 10 mm to 20 mm towards the rear, slightly tilt towards the bottom and then pull out completely.
- Pull off cable from powersupply to option R&S CMU-B66/B68, if fitted (modell SN250 (1091.1982.00 only))

Installing the new POWER SUPPLY

- Install the new POWER SUPPLY in the reverse order.
 - Note:** *Make sure that the 96-pin connector to the MOTHERBOARD1 locks in place correctly and the cable to option R&S CMU-B66/68 is fitted (only with model SN250 1091.1982.00).*
- Connect the instrument to the mains and switch on.

Replacing the Instrument Fan

(see chapter 5, spare part list, Current No. 5001, and explosion drawing 1100.0008.01 D sheet 2)

The fan is fitted at the right side panel of the R&S CMU in an air duct. For replacement proceed as follows:

Opening the instrument and removing the fan

- Switch off the instrument, pull the mains plug and unscrew the rear-panel feet.
- Place the instrument onto the front carrying handles, push the tube upwards and take off.
- Place the instrument onto the left side and locate the fan connecting cable. Coming from the air duct, the cable leads to connector X211 at MOTHERBOARD1 near the Option OCXO REFERENCE OSC. If this is installed, it can as well be removed in order to enable easier access to the fan connector (see replacing the OPTION OCXO REFERENCE OSC.).
- Pull off the connector from MOTHERBOARD1. To this end, press the locking lever at the top of the connector towards the connector and lift off the cable.
- Lever off the cover of the air duct and unscrew the four countersunk screws of the fan in the right side panel of the R&S CMU. Carefully take out the fan towards the top and pull the connecting cable through the hole in the air duct (Take off the adhesive tapes of the cable entry and keep them for later).

Installing the new fan and completing the instrument

- Replace the new fan in the reverse order.
 - Note:** *Make sure that the air direction of the fan is such that air is sucked in from the right side of the R&S CMU and pressed through the air duct. Note the arrows on the fan casing.*
- Reconnect the fan connecting cable to MOTHERBOARD1 (Fix again the adhesive tapes of the cable entry).
- Complete the instrument without causing damage to the cables.
- Connect the instrument to the mains and switch on.

Replacing the MOTHERBOARD (1100.0908.02)

(see chapter 5, spare part list, *Current No. 1201 (MOTHERBOARD)*, and explosion drawing 1100.0008.01 D sheet 2)

The MOTHERBOARD consists of five parts: MOTHERBOARD1, MOTHERBOARD2, FRONT PANEL BOARD, REARPANEL BOARD1 and REARPANEL BOARD2.

For replacement of the individual parts proceed as follows:

MOTHERBOARD1 (big MOTHERBOARD)

Opening the instrument and removing MOTHERBOARD1

- Switch off the instrument, pull the mains plug and unscrew the rear-panel feet.
- Place the instrument onto the front carrying handles, push the tube upwards and take off.
- After unscrewing the two countersunk screws at the top left instrument frame slightly lift the cover at the top of the instrument, slightly shift towards the right and lift off.
- Loosen all connecting cables to the boards, then lever out all boards as described above using the two levers at the right and at the left.
- Likewise, remove the POWER SUPPLY and the FRONT MODULE, disconnect the ribbon cable connections to the RF-FRONTEND, MOTHERBOARD2, FRONT PANEL BOARD, REARPANEL BOARD1 and REARPANEL BOARD2. Disconnect the fan connecting cable and remove the Option OCXO REFERENCE OSC, if installed.
- Remove the partition inserted between air duct and module support as reinforcement by unscrewing the four screws.
- Place the instrument upside down and unscrew all the five combi screws on MOTHERBOARD1, then slightly shift MOTHERBOARD1 towards the rear until the six motherboard supports slide out of the keyholes. Then swing out MOTHERBOARD1 towards the top.

Installing the new MOTHERBOARD1 and completing the instrument

- Insert new MOTHERBOARD1 and connect all connectors and modules in the reverse order.
- Complete the instrument without causing damage to the cables.
- Connect the instrument to the mains and switch on.

MOTHERBOARD2 (small MOTHERBOARD)**Opening the instrument and removing MOTHERBOARD2**

- Switch off the instrument and pull the mains plug and unscrew the rear-panel feet.
- Place the instrument onto the front carrying handles, push the tube upwards and take off.
- Unscrew the combi screw of the module locking bracket near the instrument fan and swing away the locking bracket towards the top.
- Disconnect all the MMCX plug-in cables (using a pull-out tool*) from the top of the REFERENCE BOARD and pull off the module.
- If installed, remove any other optional module next to the REFERENCE BOARD.
- Disconnect the two ribbon cables from the MOTHERBOARD2. Unscrew the four screws from MOTHERBOARD2 and take out.

Installing the new MOTHERBOARD2 and completing the instrument

- Replace new MOTHERBOARD2, fasten with screws and connect all connectors and modules in the reverse order.
- Complete the instrument without causing damage to the cables.
- Connect the instrument to the mains and switch on.

FRONTPANEL BOARD (at the front of the instrument frame)**Opening the instrument and removing the FRONTPANEL BOARD**

- Switch off the instrument and pull the mains plug and unscrew the rear-panel feet.
- Place the instrument onto the front carrying handles, push the tube upwards and take off.
- Remove the FRONT MODULE as described above.
- Unscrew the four countersunk screws of part of the mounting plate in the front frame at the bottom and the top, loosen the two ribbon cables from MOTHERBOARD1 and the MMCX coax cables (using a pull-out tool*) on the option (if installed) next to the REFERENCE BOARD.
- Loosen all interface screws on part of the mounting plate and take out the FRONTPANELBOARD.

Installing the new FRONTPANEL BOARD and completing the instrument

- Install new FRONTPANEL BOARD, fasten with screws and connect all connectors and modules in the reverse order.
- Complete the instrument without causing damage to the cables.
- Connect the instrument to the mains and switch on.

* available in CMU-Service Kit CMU-Z3 (1100.7690.02)

REARPANEL BOARD1 (Interface board for Standard Connectors at the Rear of the Instrument Frame)

Opening the instrument and removing the REARPANEL BOARD1

- Switch off the instrument and pull the mains plug and unscrew the rear-panel feet.
- Place the instrument onto the front carrying handles, push the tube upwards and take off.
- Place the instrument onto the left side.
- Pull off the two ribbon cables of the REARPANEL BOARD1 on MOTHERBOARD1.
- Loosen all interface screws on the integrated rear panel below the POWER SUPPLY and take out the REARPANEL BOARD1.

Installing the new REARPANEL BOARD1 and completing the instrument

- Install new REARPANEL BOARD1, fasten with screws and connect all connectors in the reverse order.
- Complete the instrument without causing damage to the cables.
- Connect the instrument to the mains and switch on.

REARPANEL BOARD2 (Interface Board for Further Connectors at the Rear of the Instrument Frame)

Opening the Instrument and removing the REARPANEL BOARD2

- Switch off the instrument and pull the mains plug and unscrew the rear-panel feet.
- Place the instrument onto the front carrying handles, push the tube upwards and take off.
- Slightly lift the cover at the top of the instrument after unscrewing the two countersunk screws on the left, slightly shift to the right and lift off.
- Place the instrument onto the left side.
- Disconnect the two ribbon cables of the REARPANEL BOARD2 from MOTHERBOARD1.
- Unscrew the 6 combi screws of the rear-panel cover and disconnect all coax cables of the BNC connectors at the respective modules. Disconnect any option connectors mounted on the integrated rear panel. Pull the rear panel towards the rear.
- Loosen all interface screws to the REARPANEL BOARD2 on the integrated rear panel and take out REARPANEL BOARD2.

Installing the new REARPANEL BOARD2 and completing the instrument

- Install new REARPANEL BOARD2, fasten with screws and connect all connectors in the reverse order.
- Complete the instrument without causing damage to the cables.
- Connect the instrument to the mains and switch on.

Replacing the MOTHERBOARD (1100.2352.02)

(see chapter 5, spare part list, Current No. 1202 (MOTHERBOARD) and explosion drawing 1100.0008.01 D sheet 2)

The MOTHERBOARD consists of four parts: MOTHERBOARD1, MOTHERBOARD2, FRONTPANEL BOARD and REARPANEL BOARD2.

For replacement of the individual parts proceed as follows:

MOTHERBOARD1 (big MOTHERBOARD)

Opening the instrument and removing MOTHERBOARD1

- Switch off the instrument, pull the mains plug and unscrew the rear-panel feet.
- Place the instrument onto the front carrying handles, push the tube upwards and take off.
- After unscrewing the two countersunk screws at the top left instrument frame slightly lift the cover at the top of the instrument, slightly shift towards the right and lift off.
- Loosen all connecting cables to the boards, then lever out all boards as described above using the two levers at the right and at the left.
- Likewise, remove the POWER SUPPLY and the FRONT MODULE, disconnect the ribbon cable connections to the RF-FRONTEND, MOTHERBOARD2, FRONTPANEL BOARD and REARPANEL BOARD2. Disconnect the fan connecting cable and remove the Option OCXO REFERENCE OSC, if installed.
- Place the instrument upside down and unscrew all the eleven combi screws on MOTHERBOARD1 and the holder for the I/O Connectors on the backside of the instrument, then slightly shift MOTHERBOARD1 towards the front and swing out MOTHERBOARD1 towards the top.

Installing the new MOTHERBOARD1 and completing the instrument

- Insert new MOTHERBOARD1 and connect all connectors and modules in the reverse order.
- Complete the instrument without causing damage to the cables.
- Connect the instrument to the mains and switch on.

MOTHERBOARD2 (small MOTHERBOARD)**Opening the instrument and removing MOTHERBOARD2**

- Switch off the instrument and pull the mains plug and unscrew the rear-panel feet.
- Place the instrument onto the front carrying handles, push the tube upwards and take off.
- Unscrew the combi screw of the module locking bracket near the instrument fan and swing away the locking bracket towards the top.
- Disconnect all the MMCX plug-in cables (using a pull-out tool*) from the top of the REFERENCE BOARD and pull off the module.
- If installed, remove any other optional module next to the REFERENCE BOARD.
- Disconnect the two ribbon cables from the MOTHERBOARD2. Unscrew the four screws from MOTHERBOARD2 and take out.

Installing the new MOTHERBOARD2 and completing the instrument

- Replace new MOTHERBOARD2, fasten with screws and connect all connectors and modules in the reverse order.
- Complete the instrument without causing damage to the cables.
- Connect the instrument to the mains and switch on.

FRONTPANEL BOARD (at the front of the instrument frame)**Opening the instrument and removing the FRONTPANEL BOARD**

- Switch off the instrument and pull the mains plug and unscrew the rear-panel feet.
- Place the instrument onto the front carrying handles, push the tube upwards and take off.
- Remove the FRONT MODULE as described above.
- Unscrew the four countersunk screws of part of the mounting plate in the front frame at the bottom and the top, loosen the two ribbon cables from MOTHERBOARD1 and the MMCX coax cables (using a pull-out tool*) on the option (if installed) next to the REFERENCE BOARD.
- Loosen all interface screws on part of the mounting plate and take out the FRONTPANELBOARD.

Installing the new FRONTPANEL BOARD and completing the instrument

- Install new FRONTPANEL BOARD, fasten with screws and connect all connectors and modules in the reverse order.
- Complete the instrument without causing damage to the cables.
- Connect the instrument to the mains and switch on.

* available in CMU-Service Kit CMU-Z3 (1100.7690.02)

REARPANEL BOARD2 (Interface Board for Further Connectors at the Rear of the Instrument Frame) Opening the Instrument and removing the REARPANEL BOARD2

- Switch off the instrument and pull the mains plug and unscrew the rear-panel feet.
- Place the instrument onto the front carrying handles, push the tube upwards and take off.
- Slightly lift the cover at the top of the instrument after unscrewing the two countersunk screws on the left, slightly shift to the right and lift off.
- Place the instrument onto the left side.
- Disconnect the two ribbon cables of the REARPANEL BOARD2 from MOTHERBOARD1.
- Unscrew the 6 combi screws of the rear-panel cover and disconnect all coax cables of the BNC connectors at the respective modules. Disconnect any option connectors mounted on the integrated rear panel. Pull the rear panel towards the rear.
- Loosen all interface screws to the REARPANEL BOARD2 on the integrated rear panel and take out REARPANEL BOARD2.

Installing the new REARPANEL BOARD2 and completing the instrument

- Install new REARPANEL BOARD2, fasten with screws and connect all connectors in the reverse order.
- Complete the instrument without causing damage to the cables.
- Connect the instrument to the mains and switch on.

Troubleshooting

Faulty functions may sometimes originate in simple causes, but sometimes they also result from faulty components.

These troubleshooting instructions permit to trace the fault down to module level and make the instrument ready for use again by means of module adjustment.

For the module adjustment and further error elimination, we recommend to send the instrument to our authorized service (see list of addresses, *preface*).

**Warning!**

Live modules must not be removed or plugged in!

Do not produce short-circuits when measuring voltages!

For simple troubleshooting, the R&S CMU provides the following tools:

- Nine green LEDs (H1 to H8) at the bottom of MOTHERBOARD1, which indicate the operating voltages.
- A SELFTEST and INFO menu, which presents voltages via the module-internal diagnosis and RF loop-measurements with internal RF generator and RF analyzer.
- ERROR messages on the LCD display with references to sources of error.

Note: *In the case of problems first check all connections for damage (cables, plug-and-socket connections etc.) or wrong positions.*

For advanced troubleshooting on board-level, see Service Manual Modules (1100.4903.94-01).

Troubleshooting using the LEDs (H1 to H8) on the MOTHERBOARD

- Fault: R&S CMU cannot be switched on.

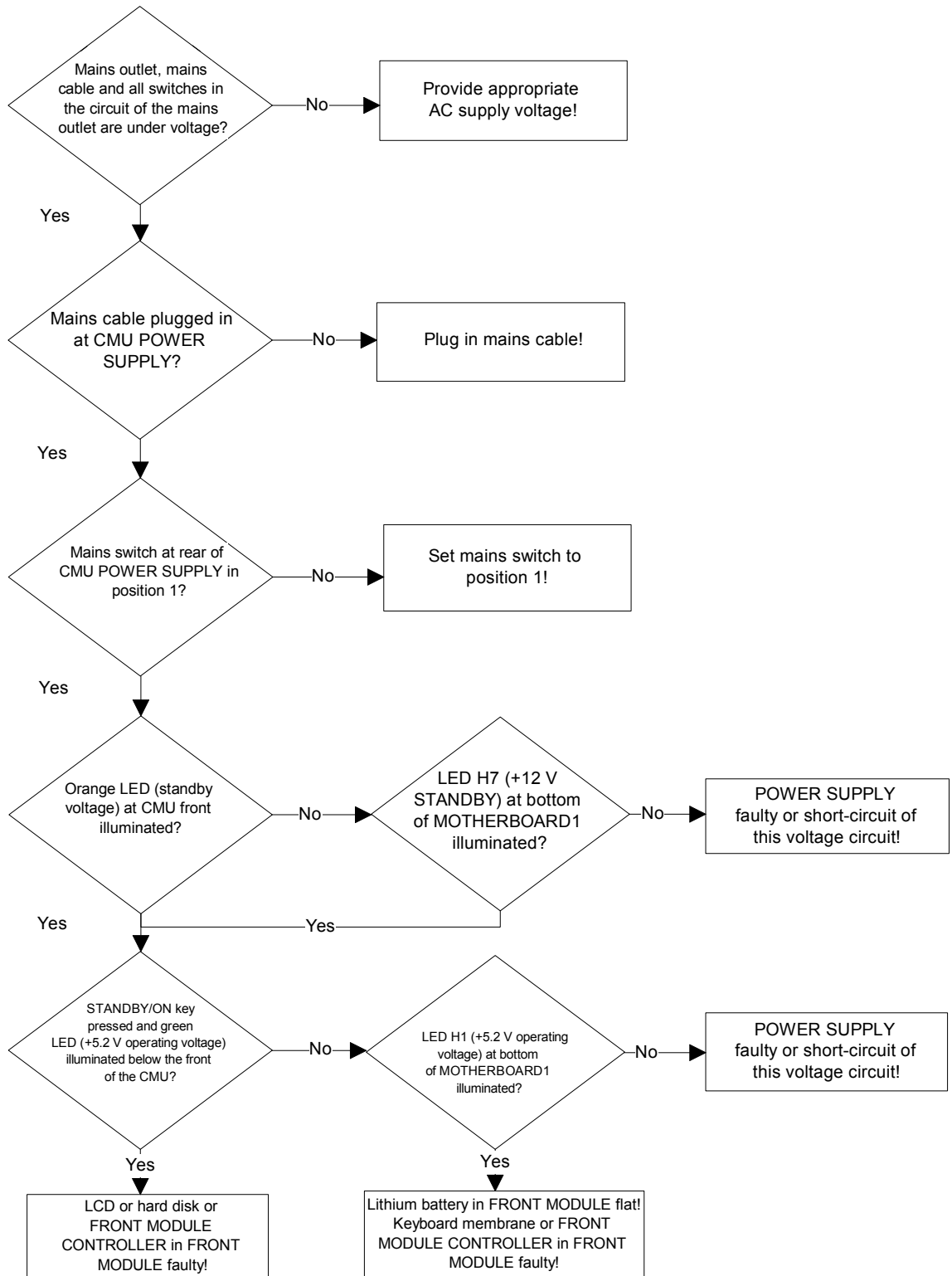

• **Fault: Short-circuit of one or several operating voltages**

- Check LEDs (H1 to H8) at the bottom of MOTHERBOARD1 to determine which voltage is short-circuited.

Note: *In the case of a short-circuit, the power supply switches off all voltages after a short period of time.
Restart is possible using the ON/STANDBY key.*

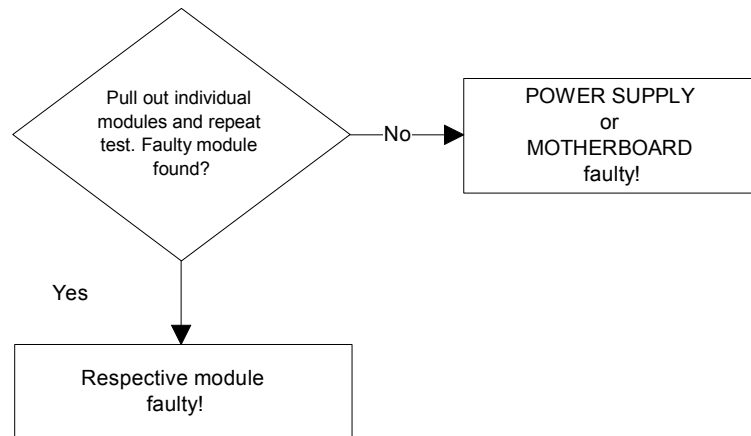

• **Fault: Instrument fan does not work.**

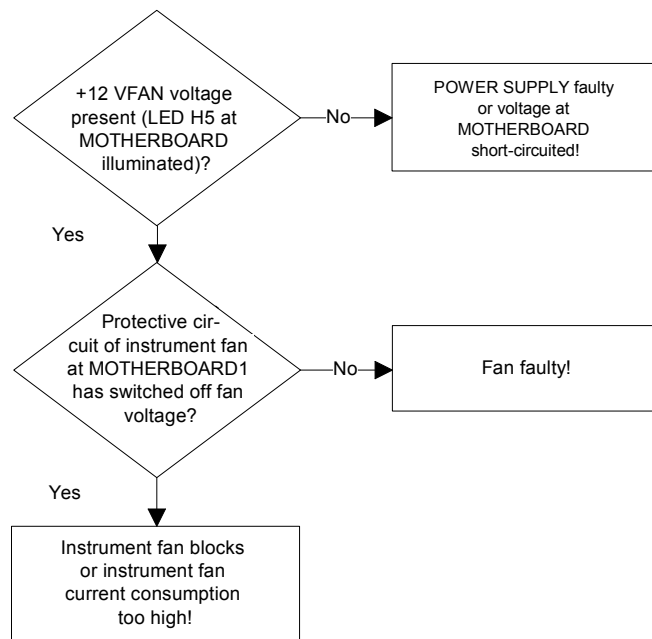

Note: *Measure instrument fan voltage at connector X 211! By pressing the STANDBY/ON key again, the protective circuit of the instrument fan can be restarted.*

Troubleshooting using the SELFTEST Menu for Modules

The SELFTEST menu indicate the diagnostic voltages for the individual modules of which the modules settings are exactly defined. Thus, a specific selftest of the respective module is possible. This menu additionally features internal RF power measurements which are designed as RF loop with internal generator and analyzer. This is why a simple RF path is possible.

The selftest menu can be called up via the *MENU SELECT* key on the front panel of the R&S CMU. Call the selection BASE via the spinwheel in the *MENU SELECT* and confirm with ENTER. The respective selftest can be selected via the softkey *SELECT* and the spinwheel.

The following selftests are available:

- Continuous Selftest¹ (Continous selftest via System Selftest and Internal RF Loop Selftest, passed/failed with error output is only indicated; additionally in case of errors, it is created an error file 'cst.err'²)
- Internal RF Loop Selftest (Selftest RF path by power measurements via internal generator and analyzer, in this case all measured values are indicated.)
- System Selftest (Selftest instrument for diagnostic voltages, passed/failed with error output is only indicated.)
- FE Selftest (Selftest Module RF FRONTEND for diagnostic voltages, in this case all measured values are indicated.)
- REF Selftest (Selftest Module REFERENCE BOARD for diagnostic voltages, in this case all measured values are indicated.)
- DIG Selftest (Selftest Module DIGITAL BOARD for diagnostic voltages, in this case all measured values are indicated.)
- RXTX1 Selftest (Selftest Module RXTX1 BOARD for diagnostic voltages, in this case all measured values are indicated.)
- 1→ 4/3→ 2 RF Loop Selftest RF Path RF1→RF4IN and RF3OUT→RF2 via external N-coax cable by power measurements via internal generator and analyser, in this case all measured values are indicated.

¹ perform the test with open connectors at RF1 and RF2

² **Note:** You can read the error file 'cst.err' as follows:
 - Connect the external keyboard connector to the rear panel of the CMU.
 - Switch on the CMU and wait until the CMU is booted.
 - Start the Continuous Selftest (only when errors have occurred, the file 'cst.err' is created. Don't finish the Continuous Selftest with OFF, otherwise the 'cst.err' file will be deleted.)
 - Press the keys ALT and F4 of the external keyboard to get to the DOS mode.
 - Goto directory: c:\internal\log
 - Read the file with the DOS editor: 'edit cst.err'
 - Quit the DOS editor and start CMU operating software with: 'cmu.bat'.

To obtain more detailed information start the following tests (depending on options and R&S CMU SW versions):

IQIF Selftest:	<i>Selftest of the R&S CMU-B17 IQIF BOARD module via diagnostic voltages. All measured values are indicated.</i>
AUXTX Selftest:	<i>Selftest of the R&S CMU-B95 AUXTX or R&S CMU-B96 AUXTX W BOARD module via diagnostic voltages. All measured values are indicated.</i>
Linkhandler Selftest:	<i>Selftest of the R&S CMU-B21 Var02 ULH and/or R&S CMU-B21 Var14 USU and/or R&S CMU-B66/B68/B76/B78 L1COPRO BOARD module. All measured values are indicated.</i>
IF3 Selftest:	<i>IF3 Level Selftest of the RXTX BOARD module (greater than Board version 11) via diagnostic voltages. All measured values are indicated.</i>
B83 Selftest:	<i>Selftest of the R&S CMU-B83 CDMA LH BOARD module. All measured values are indicated.</i>
RXTX2 Selftest:	<i>Selftest of the RXTX2 BOARD (if available) module via diagnostic voltages. All measured values are indicated.</i>

After having selected and confirming with the ENTER key, the test can be started by selecting the TEST softkey and the ON key.

Pressing the REPORT softkey and turning the spinwheel the indicated page can be pulled up and down. If errors (red color) are produced by this test, the error will be found out and eliminated on the respective module.

Troubleshooting using the ERROR messages on the LC display

Error message	Error description	Troubleshooting to
These clocks are not present: NET_CLOCK_1 NET_CLOCK_2	Netclock 1 / 2 not present	REFERENCE BOARD, DIGITAL BOARD, MMCX cable W31/W32
These clocks are not present: FIXED_CLOCK	110.8MHz Reference clock not present	REFERENCE BOARD, DIGITAL BOARD, MMCX cable W33
DIG diag adc cal error	Calibration error of the diagnosis AC/DC converter	DIGITAL BOARD
FE pow adc cal error	Calibration error of the power meter AC/DC converter	RF FRONTEND
FE eeprom data error FE power meter data error	General eeprom data error Eeprom power meter data error	RF FRONTEND RF FRONTEND
timeout in 331 handshake	Communication error correction processor	TR-CORRECTION MODULE on RXTX BOARD

More troubleshooting

General errors on the transmitter side of the R&S CMU

Error description	Troubleshooting to
Setting frequency in the module test faulty	REFERENCE BOARD MMCX cable W12 RXTX BOARD1 TR-CORRECTION MODULE1 MMCX cable W17 AUC MODULE1 TX DSP MODULE1
Setting frequency in the signalling test faulty	UNIV. SIGN. UNIT DIGITAL BOARD
Setting level in the module test faulty	RF FRONTEND SMA-cable W13 RXTX BOARD1 TR-CORRECTION MODULE1 MMCX cable W17 AUC MODULE1 TX DSP MODULE1
Setting level in the signalling test faulty	UNIV. SIGN. UNIT DIGITAL BOARD
Modulation in the module test faulty	DIGITAL BOARD AUC MODULE1 TX DSP MODULE1
Modulation in the signalling test faulty	DIGITAL BOARD AUC MODULE 1 UNIV. SIGN. UNIT

General errors on the receiver side of the R&S CMU

Error description	Troubleshooting to
Received frequency in the module test faulty	REFERENCE BOARD MMCX cable W12 RXTX BOARD1 TR-CORRECTION MODULE1 MMCX cable W19 ADC MODULE1 DDC MODULE1
Received frequency in the signalling test faulty	UNIV. SIGN. UNIT DIGITAL BOARD
Received level in the module test faulty	RF FRONTEND SMA-cable W14 RXTX BOARD1 TR-CORRECTION MODULE1 MMCX cable W19 ADC MODULE1 DDC MODULE1
Received level in the signalling test faulty	RF FRONTEND SMA-cable W14 RXTX BOARD1 TR-CORRECTION MODULE1 MMCX cable W19 ADC MODULE1 DDC MODULE1 UNIV.SIGN. UNIT
Trigger releases no measurement RF POWER IF POWER	RF FRONTEND DIGITAL BOARD DDC-MODULE1 RXTX BOARD1 DIGITAL BOARD DDC-MODULE1

4 Software Update/Installing Options

This chapter contains information on extensions and modifications of the CMU. Information or manuals obtained together with a software/firmware update or with additional hardware options can be filed here.

New Installation of the CMU Software

A software update can be performed in the CMU using the PCMCIA INTERFACE or the FLOPPY DISK DRIVE (R&S CMU -U61).

One of these is always installed in the R&S CMU (compulsory option).

The software update is carried out in the R&S CMU using the *VersionManager*. This tool enables convenient installation, deletion and activation of different software versions. It also permits to perform a firmware update of modules following module replacement (see chapter 2, *Automatic Adjustment*).

The R&S CMU is always supplied with the latest software version including the version manager.

Note: *The newest R&S CMU software is also available at the R&S Lotus Notes Service Board.*

Software Update via PCMCIA INTERFACE

For the PCMCIA INTERFACE, two drive slots are provided. Both drive slots can be used for the software update; the R&S CMU automatically searches for an installation medium in both slots. The flash disks and the hard disk (type 3) feature a small groove on one side; the disks are to be inserted into the drive slot with the groove pointing upwards.

Note: *The drive designation is as follows: right drive slot (slot 0) is drive D; left drive slot (slot 1) is drive E. Hard disks can only be inserted into the right drive slot (Slot 0; drive D:).*

To perform the software update, the instrument must be switched off, then the software update flash disk or hard disk must be inserted into the PCMCIA INTERFACE on the instrument and the instrument switched on. If necessary, further update flash disks must be inserted one after the other. Please follow the hints in the *VersionManager*.

Software Update via FLOPPY DISK DRIVE

To perform the software update, the instrument must be switched off, then the first software update floppy ('3.5') must be inserted into the FLOPPY DISK DRIVE of the instrument and the instrument switched on.

Then the further update floppies must be inserted one after the other. Please follow the hints in the **VersionManager**.

Performing a Software Update

On start-up, an automatic test is made to check whether an update floppy disk or a flash disk/hard disk is available. If this is the case, the version manager is started, displaying the following possible selections:

VersionManager Ver X.X

The active R&S CMU software is the version: [active version]

- ← activate other software version
- ← delete a software version
- ← install software version from FLOPPY DISK DRIVE or PCMCIA Slot X
- ← firmware update after board change
- ← edit service tables
- ← exit

In the above menu, an action can be selected using the softkey located to the left of the arrow.

- For the software update select the action *install new software version* from the Floppy DISK DRIVE or the PCMCIA Slot X.
- Press the softkey to the left of the above mentioned menu item. An overview of the software versions that already provided on the installation media will appear.
- Select the desired version by pressing the softkey to the left of the arrow.

The software update will then start automatically, prompting the user to insert a further update floppy disk or flash disk, if necessary. Confirm using the ENTER hardkey.

Note: *In the case of several update floppy disks or flash disks always observe the order of the disk numbers.*

- When all update floppy disks or flash disks have been loaded, the instrument prompts:
Remove installation media and press ENTER key.

The R&S CMU boots again and automatically performs a firmware update of the hardware boards. This may take a few minutes. Then the new software version will start and the R&S CMU is ready for use.

Reinstalling the Old Software

As described above, each software version, even older versions, can be simply loaded from a appropriate floppy disk or flash disk/hard disk using the version manager. It is also possible to keep several software versions stored on the hard disk in the R&S CMU and reload them, if required, using the version manager. To this end, proceed as follows:

- During start-up observe the display.
- When three BEEPs can be heard, press the *MENU SELECT* key.
The version manager is now started (see also chapter 4, *Software Update*). The display includes the menu item *activate other software version*.
- Press the softkey to the left of the above mentioned menu item.
An overview of the software versions that are already provided in the R&S CMU will appear.
- Select the desired version by pressing the softkey to the left of the arrow.

The selected software version is loaded. After the firmware update of the hardware boards has been terminated, the operating software starts automatically and the R&S CMU is ready for use and can be operated as usual.

Loading Software as long as there is no VersionManager in the R&S CMU

In case of unintentional deletion of the version manager, new loading of the version manager is necessary.

For this purpose, a software update floppy disk or flash disk type 2 / hard disk (type 3) and an external keyboard to be plugged in at the rear panel of the R&S CMU at the KEYBOARD connector are required.

- Insert software update floppy disk No. 1 or flash disk / hard disk into the respective drive, switch on the R&S CMU and use the external keyboard to select drive a: (with floppy disk drive) or d:/e: (with flash disk/hard disk) when the DOS prompt appears.

Note: *Using the hardkey combination 'Alt' and 'F4' on the external keyboard you get from the operating software into the DOS mode.*

- Change to the subdirectory of the update floppy or flash disk/hard disk (cd\...).
- Enter the command `install.bat a:/d:/e:` (corresponding to the respective drive) via the external keyboard.
- Confirm using the ENTER hardkey.

The version manager will be loaded and a software update can then be performed as described above.

Installing the Options

Depending on the model ordered and the software configuration, the R&S CMU comes with part of the options installed in the factory.

Most of the options just be installed by an authorized Rohde & Schwarz service representative. Please refer to the notes on the title page of the installation instruction.

Caution!



Disconnect the instrument from the mains before opening the casing. Also note the safety instructions at the beginning of this manual.

The components used in the instrument are sensitive to electrostatic discharges which is why they are to be handled in accordance with the ESD regulations.

When installing hardware options please note the following:

- Switch off instrument and pull the mains plug.
- Unscrew rear panel feet of the rear side (four Phillips screws, size 2).
- Place the instrument onto the front carrying handles, push the tube upwards and take off.
- After installing the option replace the tube and fasten the rear panel feet again.

Caution!



When replacing the tube take care not to damage or pull off cables.

- Switch on R&S CMU. Install additional software, if supplied, according to the instructions (see section *New Installation of the CMU Software*) or enable the additional software functions (see Installation instructions for the respective option). The software will then automatically detect the installed option (option display can be called using the *SETUP* key and the item *Options!*). If an adjustment is required for this option, the appropriate hints are to be found in the installation instructions for the option.

SW Packages for various network tests R&S CMU-Kxx

The software options do not require opening of the instrument. Proceed according to the instructions enclosed with the options.

See also description of software update and version management in Chapter 1 of the R&S CMU Quick Start Guides.

5 Documents

This chapter contains the spare parts list and the documents for the complete R&S CMU unit. For general information about spare parts for our products please refer to the sheet “Procedure in Case of Service and Ordering of Spare Parts” at the beginning of this manual.

Spare Parts

The stock numbers necessary for ordering replacement parts and modules can be found in the component lists further down.

CAUTION



Risk of shock hazard and instrument damage

When replacing a module please note the safety instructions and the repair instructions given in chapter 3 and at the beginning of this service manual

When shipping a module be careful to provide for sufficient mechanical and anti-static protection.

Available Power Cables

Table 0-1 List of power cables available

Stock No.	Earthed-contact connector	Preferably used in
DS 0006.7013.00	BS1363: 1967' 10 A 250 V complying with IEC 83: 1975 standard B2	Great Britain
DS 0006.7020.00	Type 12 , 10 A 250 V complying with SEV-regulation 1011.1059, standard sheet S 24 507	Switzerland
DS 0006.7036.00	Type 498/13 10 A 250 V complying with US-regulation UL 498, or with IEC 83	USA/Canada
DS 0041.4752.00	GB2099 , GB1002 10 A 250 V approvals CCC	China
DS 0041.6232.00	JIS C 8303 7A 125V AC approvals PSE (JET)	Japan
DS 0006.7107.00	Type SAA3 10 A, 250 V, complying with AS C112-1964 Ap.	Australia
DS 0025.2365.00	DIN 49 441, 10 A, 250 V, straight approvals VDE,ÖVE,CEBEC,KEMA,S,D,N,FI,LCIE,IMQ,UCIEE	Europe (except Switzerland)
DS 0086.4400.00	DIN 49 441, 10 A, 250 V, angular approvals VDE,ÖVE,CEBEC,KEMA,S,D,N,FI,LCIE,IMQ,UCIEE	

**Overview of
Spare Parts
for CMU Basic Unit**

Für diese Unterlage behalten wir uns alle Rechte vor.
 Ausgedruckte Dokumente unterliegen nicht dem Änderungsdienst.
 For this document all rights are reserved.
 Printed documents are not subject to revision

Pos.-Nr. ItemNo	Menge Quantity	ME Unit	El.Kennz Ref.Des.	Benennung / Bezeichnung Designation	Z	Sachnummer Stock No.	Ersatzteil Subst.part	BA	VH
				ACHTUNG EGB/ATTENTION ESD *VARIANTENERKLAERUNG *EXPLANATION OF MODELS VAR02=ERSATZTEILE CMU200 MOD02=SPARE PARTS CMU200 VAR03=ERSATZTEILE CMU300 MOD03=SPARE PARTS CMU300 VAR10=ERSATZTEILE CMU200/VAR10 MOD10=SPARE PARTS CMU200/MOD10 VAR30=ERSATZTEILE CMU200/VAR30 MOD30=SPARE PARTS CMU200/MOD30 VAR53=ERSATZTEILE CMU200/VAR53 MOD53=SPARE PARTS CMU200/MOD53					
100	0	S	A1	ZE FRONTMODUL FRONT MODULE Replaced by 1090.9244.22	Z	1090.9244.12		M	
101	0	S	A1	ZE FRONTMODUL FRONT MODULE Replaced by 1090.9244.23	Z	1090.9244.22		M	
102	0	S	A1	ZE FRONTMODUL FRONTMODUL Replaced by 1090.9244.24	Z	1090.9244.23		M	O
103	1	S	A1	ZE FRONTMODUL FRONTMODUL	Z	1090.9244.24		M	O
110	0	S	A4	GR FMR5 VARIANTE FRONT MOD. CONTROLLER included in 1090.9244.12 Replaced by 1091.2689.00		1091.2789.00		B	A
111	0	S	A4	GR FMR5+ FRONT MOD. CONTROLLER included in 1090.9244.12 Replaced by 1091.2720.00		1091.2689.00		B	A
120	0	S	A4	GR FMR6/1 FRONT MOD. CONTROLLER included in 1090.9244.22 Replaced by 1091.2750.00		1091.2720.00		B	G
121	0	S	A4	GR FMR6/2 FRONT MOD. CONTROLLER included in 1090.9244.22 Replaced by 1091.2808.00		1091.2750.00		B	A
122	0	S	A4	GR FMR6/1+ FRONTMOD. CONTR. 6/1+ included in 1090.9244.23 Replaced by 1091.2814.00		1091.2808.00		B	A
123	1	S	A4	GR FMR 6/1+ FRONTMOD.CONTR.6/1+ included in 1090.9244.24		1091.2814.00		B	A
130	0	S		MZ WANNE included in 1090.9244.12	Z	1090.9650.00		M	
131	1	S		MZ RECHNERWANNE TUB included in 1090.9244.22/23/24	Z	1090.9421.00		M	O
140	0	S	W17	DF DISPLAYVERBINDER CABLE included in 1090.9244.12 Replaced by 1091.2620.00		1091.0911.00		B	O
141	0	S	W17	GR DISPL.VERB.FMR6-SHARP DISPL.CONNECT FMR6-SHARP included in 1090.9244.22/23		1091.2620.00		B	G



ROHDE & SCHWARZ

Benennung/Designation

**ERSATZTEILE CMU
SPARE PARTS CMU**

Sprach./Lang

de en

Ä.I. / C.I

18.00

Blatt/Sheet

1 of 12

Dokument Nr. / Document No.

1100.0114.01 ST

Datum/
Date

2006-06-19

Abt. /
Dept.

1CMK

Name /
Name

GL

Für diese Unterlage behalten wir uns alle Rechte vor.
 Ausgedruckte Dokumente unterliegen nicht dem Änderungsdienst.
 For this document all rights are reserved.
 Printed documents are not subject to revision

Pos.-Nr. ItemNo	Menge Quantity	ME Unit	El.Kennz Ref.Des.	Benennung / Bezeichnung Designation	Z	Sachnummer Stock No.	Ersatzteil Subst.part	BA	VH
142	1	S	W17	Replaced by 1091.2743.00 GR DISPL.VERB.FMR6-SHARP DISPL.CONNECT FMR6-SHARP included in 1090.9244.22/23/24		1091.2743.00		B	V
150	0	S	W13	DF WANDLERKABEL L=190 CABLE replaced by 1091.2643.00		1091.0928.00		B	O
151	1	S	W13	DF WANDLERKAB.L=350 10POL CABLE 350MM 10PIN included in 1090.9244.22/23/24		1091.2643.00		B	T
160	0	S		OS SCHALTMATTE SWITCHING PAD included only in 1090.9244.12 Replaced by 1091.2543.00	Z	1100.0166.00		M	G
161	1	S		SF SCHALTMATTE 65T CMU KEY SET included in 1090.9244.12/22/23/24	Z	1091.2543.00		B	V
170	0	S	A15	SF SCHALTFOIE 65T PLATT FLEXIBLE SWITCH BOARD included only in 1090.9244.12 Replaced by 1091.2550.00		1091.2008.00		B	V
171	1	S	A15	SF SCHALTFOIE 65T CMU SWITCH FOIL included in 1090.9244.12/22/23/24 valid from 06.2001		1091.2550.00		B	O
180	0	S		ZM TASTATURRAHMEN KEYBOARD FRAME included only in 1090.9244.12 Replaced by 1091.2572.00		1091.1153.00		M	
181	1	S		MP TASTATURRAHMEN CMU FRAME FOR KEYBOARD CMU included in 1090.9244.12/22/23/24		1091.2572.00		B	V
190	1	S		MZ MONTAGEWANNE MOUNTING TUB included in 1090.9244.12/22/23/24	Z	1090.9680.00		M	
200	0	S	B12	EM DREHIMPULSGEBER MIT TASTER ROTARY PULSE ENCODER included in 1090.9244.12/22 Replaced by 0852.2718.00		0852.1134.00		B	A
201	1	S	B12	EM DREHIMP.2 (M.TAS./GEW. ROTARY PULS-GENERATOR included in 1090.9244.22/23/24		0852.2718.00		B	V
210	1	S		EB 3.6V 1.00AH LI-SOCL2 LITHIUM THIONYL CHLORIDE BATTERY included in 1090.9244.12		0565.1687.00		B	O
211	1	S		GE 3.0V 230MAH LI-MNO2 LITHIUM BATTERY CR2032 included in 1090.9244.22/23/24		0858.2049.00		B	V
220	1	S	U24 U25	GP 256MB SOD F. FMR5 (+) 256MB SDRAM SODIMM144 included in 1090.9244.12		1091.2837.00		B	V
230	1	S	U2 U3	GP 256MB SODIMM F. FMR6 256MB SDRAM SODIMM144 included in 1090.9244.22/23/24		1091.2850.00		B	V
231	1	S	U2 U3	GP 256MB SODIMM F. FMR6+ 256MB SODIMM F. FMR6+ included in 1090.9244.22/23/24		1138.6678.00		B	V



ROHDE & SCHWARZ

Benennung/Designation

**ERSATZTEILE CMU
SPARE PARTS CMU**

Sprach./Lang
de en

Ä.I. / C.I
18.00

Blatt/Sheet
2 of 12

Dokument Nr. / Document No.

1100.0114.01 ST

Datum/
Date

2006-06-19

Abt. /
Dept.

1CMK

Name /
Name

GL

Für diese Unterlage behalten wir uns alle Rechte vor.
 Ausgedruckte Dokumente unterliegen nicht dem Änderungsdienst.
 For this document all rights are reserved.
 Printed documents are not subject to revision

Pos.-Nr. ItemNo	Menge Quantity	ME Unit	El.Kennz Ref.Des.	Benennung / Bezeichnung Designation	Z	Sachnummer Stock No.	Ersatzteil Subst.part	BA	VH
250	1	S	A14	BP TFT 8.4 VGA DRGB CCFL 8.4 COLOR LCD MODULE included in 1090.9244.12/22/23/24		0048.6980.00		B	V
251	1	S	E10	DX LUEFTEREINHEIT FAN UNIT included in 1090.9244.12/22/23/24		1091.0292.00		M	
252	1	S		GR LUEFTER F. FMR5+ / 6+ BLOWER F. FMR5+ / 6+ included in 1090.9244.12/22/23		1091.2943.00		B	O
253	1	S	T3	BP CXA-L0605-VJL DC-AC DC TO AC INVERTER UNIT included in 1090.9244.12/22/23/24		0048.6996.00		B	T
255	1	S		OP FILTERSCHEIBE GESCHIR. SCREENED FILTER GLASS included in 1090.9244.12/22/23/24		1091.2014.00		B	V
256	2	S		MZ HF-FEDER (177) RF SPRING included in 1090.9244.12/22/23/24	Z	1069.3011.00		M	
257	2	S		MZ HF-FEDER (137) RF SPRING included in 1090.9244.12/22/23/24	Z	1069.3105.00		M	
258	4	S		MM SCHEIBENHALTER DISK HOLDER included in 1090.9244.12/22/23/24		0852.0844.00		M	
259	1	S		OK DREH.RD28 ACHS-RD6 KNOB included in 1090.9244.12/22/23/24		0852.1086.00		B	T
260	1	S	D1	ZE HARD DISK PROGR. CMU HARD DISK PROGR. CMU	Z	1100.0989.00		M	
261	1	S		MZ STAUBABDICHTUNG DUST COVER included in 1090.9244.22/23/24	Z	1093.5279.00		M	
300	0	S	A3	EE RX/TX BOARD RX/TX BOARD Replaced by 1100.1733.02 Adjustment with ACS114 necessary	Z	1100.1404.02		M	
301	0	S	A3	EE RX/TX BOARD RX/TX BOARD Replaced by 1135.6702.02 Adjustment with ACS114 necessary	Z	1100.1733.02		M	
302	0	S	A3	EE RX/TX BOARD RX/TX BOARD Replaced by 1135.6925.02 Adjustment with ACS114 necessary	Z	1135.6702.02		M	
303	1	S	A3	EE RX/TX BOARD RX/TX BOARD Adjustment with ACS114 necessary	Z	1135.6925.02		M	
310	1	S		EP 1842.5MHZ-BANDPASS-FI. BANDPASS FILTER Included in 1100.1404.02, 1100.1733.02, 1135.6702.02, 1135.6925.02		1100.4255.00		B	O
311	1	S		EP 836.5MHZ-BANDPASS-FI. BANDPASS FILTER Included in 1100.1404.02, 1100.1733.02, 1135.6702.02, 1135.6925.02		1100.4261.00		B	O
312	1	S		EP 10.7MHZBANDP.KER.B350K 10.7MHZ CERAMIC BANDPASS		1100.4661.00		B	O



ROHDE & SCHWARZ

Benennung/Designation

**ERSATZTEILE CMU
SPARE PARTS CMU**

Sprach./Lang
de en

Ä.I. / C.I
18.00

Blatt/Sheet
3 of 12

Dokument Nr. / Document No.

1100.0114.01 ST

Datum/
Date

2006-06-19

Abt. /
Dept.

1CMK

Name /
Name

GL

Für diese Unterlage behalten wir uns alle Rechte vor.
 Ausgedruckte Dokumente unterliegen nicht dem Änderungsdienst.
 For this document all rights are reserved.
 Printed documents are not subject to revision

Pos.-Nr. ItemNo	Menge Quantity	ME Unit	El.Kennz Ref.Des.	Benennung / Bezeichnung Designation	Z	Sachnummer Stock No.	Ersatzteil Subst.part	BA	VH
313	1	S		Included in 1100.1404.02, 1100.1733.02, 1135.6702.02 EP 479.75MHZ SAW-BP SAW FILTER Included in 1100.1404.02, 1100.1733.02, 1135.6925.02		1100.4278.00		B	V
314	1	S		ER KERAMIK RESONATOR 550M CERAMIC RESONATOR Included in 1100.1404.02, 1100.1733.02, 1135.6702.02, 1135.6925.02		1100.4426.00		B	V
320	1	S		EE TR-CORRECTION MODULE TR-CORRECTION MODULE included in 1100.1404.02 included in 1100.1733.02 included in 1135.6702.02 included in 1135.6925.02	Z	1100.1604.02		M	
330	1	S		EE RX IF3 MODULE included in 1135.6925.02	Z	1135.6983.02		M	
700	0	S	A7	ZE DIGITAL UNIT DIGITAL UNIT ZE Digital Board (ZE = complete assembled module) Replaced by 1100.1791.04 Adjustment with ACS114 necessary	Z	1100.1791.02		M	
701	0	S	A7	ZE DIGITALBOARD DIGITAL BOARD ZE Digital Board (ZE = complete assembled module) Replaced by 1100.1940.04 Adjustment with ACS114 necessary	Z	1100.1791.04		M	
702	0	S	A7	ZE DIGITALTEIL 2 DIGITAL UNIT 2 ZE Digital Board (ZE = complete assembled module) Replaced by 1100.1940.06 Adjustment with ACS114 necessary	Z	1100.1940.04		M	O
703	1	S	A7	ZE DIGITALTEIL 2 DIGITAL UNIT 2 ZE Digital Board (ZE = complete assembled module) Adjustment with ACS114 necessary	Z	1100.1940.06		M	O
704	0	S		PB BEMERKUNG NOTE Attention: For detailed information reg. different modules in ZE Digital Board please refer to service circular No. 1636		0999.9610.00		B	O
705	0	S	A700	EE DIGITAL BOARD DIGITAL BOARD Digital Board (Baseboard) Included in ZE Digital Board 1100.1791.02 Replaced by 1100.1804.04 Only in combination with ADC Module 1100.2200.02	Z	1100.1804.02		M	
706	0	S	A700	EE DIGITAL BOARD DIGITAL BOARD Digital Board (Baseboard) Included in ZE Digital Board 1100.1791.04 Only in combination with WADC Module 1100.2275.02	Z	1100.1804.04		M	
707	1	S	A700	EE DIGITAL BOARD 2 DIGITAL BOARD 2 Digital Board (Baseboard)	Z	1100.1956.04		M	



ROHDE & SCHWARZ

Benennung/Designation

**ERSATZTEILE CMU
SPARE PARTS CMU**

Sprach./Lang
de en

Ä.I. / C./
18.00

Blatt/Sheet
4 of 12

Dokument Nr. / Document No.

1100.0114.01 ST

Datum/
Date

2006-06-19

Abt. /
Dept.

1CMK

Name /
Name

GL

Für diese Unterlage behalten wir uns alle Rechte vor.
 Ausgedruckte Dokumente unterliegen nicht dem Änderungsdienst.
 For this document all rights are reserved.
 Printed documents are not subject to revision

Pos.-Nr. ItemNo	Menge Quantity	ME Unit	El.Kennz Ref.Des.	Benennung / Bezeichnung Designation	Z	Sachnummer Stock No.	Ersatzteil Subst.part	BA	VH
				Included in ZE Digital Board 1100.1940.04/06 Only in combination with WADC Module 1100.2275.02					
710	0	S	A710	EE DDC MODULE DDC MODULE Included in ZE Digital Board 1100.1791.02/04, 1100.1940.04 Replaced by 1100.3220.02	Z	1100.2300.03		M	
711	0	S		EE DDC400 MODULE DDC400 MODULE included in CMU-U65 1100.7402.02	Z	1100.3459.02		M	
712	1	S	A710	EE WDDC400 MODULE WDDC400 MODULE Included in ZE Digital Board 1100.1940.06 Included in CMU-U65, CMU-U75	Z	1100.3220.02		M	
720	0	S	A720	EE ADC MODULE ADC MODULE Included in ZE Digital Board 1100.1791.02 Replaced by 1100.2275.02	Z	1100.2200.02		M	
721	1	S	A720	EE WADC MODULE WADC MODULE Included in ZE Digital Board 1100.1791.04, 1100.1940.04/06 Only in combination with Digital-Baseboard 1100.1804.04 and 1100.1956.04 Adjustment with ACS114 necessary	Z	1100.2275.02		M	
750	0	S	A750	EE TXDSP MODULE TXDSP MODULE Included in ZE Digital Board 1100.1791.02/04 Replaced by 1100.2130.02	Z	1100.2100.03		M	
751	1	S	A750	EE TXDSP MODULE TXDSP MODULE Included in ZE Digital Board 1100.1791.02/04, 1100.1940.04/06	Z	1100.2130.03		M	
760	1	S	A760	ED AUC_MODULE AUC MODULE Included in ZE Digital Board 1100.1791.02/04, 1100.1940.04/06 Adjustment with ACS114 necessary	Z	1100.2500.02		M	
1000	0	S	A100	GJ NETZTEIL 230W UL/CSA POWER SUPPLY Replaced by 1091.1982.00		1091.2320.00		B	V
1010	1	S	A100	GJ NETZTEIL 250W UL/CSA POWER SUPPLY Please see service circular No. 1583 !		1091.1982.00		B	V
1011	1	S		DF KABEL L=400 CABLE		1149.9596.00		B	O
1020	0	S	A20	ED RF FRONTEND RF FRONTEND Replaced by 1100.3120.02 Adjustment with ACS114 necessary Old FE 1100.3042.04 was not used in CMU- B/U99	Z	1100.3042.02		M	
1021	1	S	A20	ED RF_FRONTEND RF FRONTEND VAR 02 03 10 53 Adjustment with ACS114 necessary	Z	1100.3120.02		M	
1025	1	S	A20	ED RF-FRONTEND RF-FRONTEND VAR 30 Included in CMU-B/U99	Z	1100.3120.04		M	



ROHDE & SCHWARZ

Benennung/Designation

**ERSATZTEILE CMU
SPARE PARTS CMU**

Sprach./Lang
de en

Ä.I. / C.I
18.00

Blatt/Sheet
5 of 12

Dokument Nr. / Document No.

1100.0114.01 ST

Datum/
Date

2006-06-19

Abt. /
Dept.

1CMK

Name /
Name

GL

Für diese Unterlage behalten wir uns alle Rechte vor.
 Ausgedruckte Dokumente unterliegen nicht dem Änderungsdienst.
 For this document all rights are reserved.
 Printed documents are not subject to revision

Pos.-Nr. ItemNo	Menge Quantity	ME Unit	El.Kennz Ref.Des.	Benennung / Bezeichnung Designation	Z	Sachnummer Stock No.	Ersatzteil Subst.part	BA	VH
				Fixed part of CMU200/MOD30 Adjustment with ACS114 necessary					
1100	1	S	A10	EE REFERENCE BOARD REFERENCE BOARD	Z	1100.2600.02		M	
1102	1	S	A102	ED PCMCIA INTERFACE PCMCIA INTERFACE	Z	1100.5616.02		M	
1103	1	S		MM KARTENEINLASS F.M.CARD SLOT F.MEMORYCARD	Z	1047.2006.00		B	O
1110	1	S	A102	GM 3.5 ZOLL FLOPPY DRIVE SLIM FLOPPY DRIVE 3.5INCH included in CMU-U61 1100.5500.02		1091.2072.00		B	N
1111	1	S		MF FLOPPYRAHMEN included in CMU-U61 1100.5500.02		1091.1318.00		M	
1112	1	S		MZ FLOPPYHALTER included in CMU-U61 1100.5500.02		1091.1353.00		M	
1113	1	S		DF FLEX-STRIPVERB.26P.R=1 FLEX-STRIP included in CMU-U61 1100.5500.02		1091.2066.00		B	O
1200	0	S	A200	ED MOTHERBOARD-SET MOTHERBOARD Replaced by 1100.0908.02	Z	1100.1027.02		M	
1201	0	S	A200	ED MOTHERBOARD-SET MOTHERBOARD Fits only in combination with old frame 1090.9209.00. Replaced by 1100.2352.02 (In combination with new frame 1090.9221.00)	Z	1100.0908.02		M	
1202	1	S	A200	ED MOTHERBOARD CMU MOTHERBOARD CMU Fits only in combination with new frame 1090.9221.00	Z	1100.2352.02		M	
2205	1	S	A205	ED OCXO REFERENCE OSC. OCXO REFERENCE OSC. Included in CMU-B11	Z	1100.2900.02		M	
2206	1	S	A205	ED OCXO REFERENCE OSC.CMUB12 OCXO REFERENCE OSC. Included in CMU-B12	Z	1100.2900.03		M	
2300	0	S		EE IQ/IF- INTERFACE BOARD IQ/IF- INTERFACE BOARD included in CMU-B17	Z	1135.6002.03		M	
2301	1	S		EE IQ/IF- INTERFACE BOARD IQ/IF- INTERFACE BOARD included in CMU-B17	Z	1135.6125.03		M	
2400	0	S	A8 A9	ZE UNIVERS. SIGN. UNIT included in old CMU-B21 Replaced by 1100.5216.03	Z	1100.5216.02		M	
2401	1	S	A8 A9	ZE UNIVERS. SIGN. UNIT included in CMU-B21/MOD02	Z	1100.5216.03		M	
2410	1	S	A400	EE LINK HANDLER LINK HANDLER included in CMU-B21/MOD02	Z	1097.3570.02		M	
2420	1	S	A430	EE I/Q OUT MODULE I/Q OUT MODULE included in CMU-B21/MOD02	Z	1100.2000.02		M	



ROHDE & SCHWARZ

Benennung/Designation

**ERSATZTEILE CMU
SPARE PARTS CMU**

Sprach./Lang

de en

Ä.I. / C.I

18.00

Blatt/Sheet

6 of 12

Dokument Nr. / Document No.

1100.0114.01 ST

Datum/
Date

2006-06-19

Abt. /
Dept.

1CMK

Name /
Name

GL

Für diese Unterlage behalten wir uns alle Rechte vor.
 Ausgedruckte Dokumente unterliegen nicht dem Änderungsdienst.
 For this document all rights are reserved.
 Printed documents are not subject to revision

Pos.-Nr. ItemNo	Menge Quantity	ME Unit	El.Kennz Ref.Des.	Benennung / Bezeichnung Designation	Z	Sachnummer Stock No.	Ersatzteil Subst.part	BA	VH
2430	0	S	A440 A450 A460 A470 A1101	EE DSP MODULE included in old CMU-B21 included in old CMU-B41 Replaced by 1097.3129.03	Z	1097.3106.03		M	
2431	1	S	A440 A450 A460 A470 A1101	EE DSP MODUL DSP MODULE included in CMU-B21/MOD02, CMU-B41 and CMU-B52/MOD02	Z	1097.3129.03		M	
2440	1	S	A420	EE SPEECH INTERFACE SPEECH CODEC included in CMU-B52/MOD02	Z	1100.2730.02		M	
2450	1	S		EE CMU BLUETOOTH ULH CMU BLUETOOTH included in CMU-B53/MOD02 and CMU-U53/MOD02	Z	1135.6502.02		M	
2460	1	S	A410	EE RAM-MODUL RAM MODULE included in CMU-B71	Z	1097.3158.02		M	
2500	1	S	A9	ZE UNIVERS. SIGN. UNIT UNIVERS. SIGN. UNIT included in CMU-B21/MOD14	Z	1135.4497.02		M	
2501	1	S	A9	ZE UNIVERS. SIGN. UNIT UNIVERS. SIGN. UNIT included in CMU-B21/MOD54, CMU-U21/MOD14	Z	1135.4497.14		M	O
2510	1	S		EE UNIVERSAL SIGNAL UNIT UNIVERSAL SIGNAL UNIT included in CMU-B21/MOD14,54, CMU- U21/MOD14	Z	1135.4500.02		M	
2520	1	S		EE SPEECH CODEC SPEECH CODEC included in CMU-B52/MOD14	Z	1135.6102.02		M	
2530	1	S		EE BLUETOOTH BLUETOOTH included in CMU-B53/MOD14	Z	1135.6202.02		M	
2540	1	S		EE MC 68K MC 68K included in CMU-B21/MOD54, CMU-U21, CMU-B54	Z	1135.4700.02		M	
2550	1	S		EE DSP MODULE 56311 DSP MODULE 56311 included in CMU-B21/MOD54, CMU-U21, CMU-B54, CMU-B55	Z	1135.4600.03		M	
2560	1	S		EE POWER QUICC II MODUL POWER QUICC II MODUL included in CMU-B56/MOD14	Z	1122.9737.22		M	
2561	1	S		EE POWER QUICC III MODUL POWER QUICC III MODUL included in CMU-B56/MOD54, CMU-U56	Z	1503.1044.22		M	
2600	1	S		EE AUDIO BOARD AUDIO BOARD	Z	1100.2800.02		M	



ROHDE & SCHWARZ

Benennung/Designation

**ERSATZTEILE CMU
SPARE PARTS CMU**

Sprach./Lang
de en

Ä.I. / C.I
18.00

Blatt/Sheet
7 of 12

Dokument Nr. / Document No.

1100.0114.01 ST

Datum/
Date

2006-06-19

Abt. /
Dept.

1CMK

Name /
Name

GL

Für diese Unterlage behalten wir uns alle Rechte vor.
 Ausgedruckte Dokumente unterliegen nicht dem Änderungsdienst.
 For this document all rights are reserved.
 Printed documents are not subject to revision

Pos.-Nr. ItemNo	Menge Quantity	ME Unit	El.Kennz Ref.Des.	Benennung / Bezeichnung Designation	Z	Sachnummer Stock No.	Ersatzteil Subst.part	BA	VH
2800	1	S		included in CMU-B41 ZE COPROCESSOR COPROCESSOR included in old CMU-B66/U66 replaced by 1135.5041.22 still included in CMU-B76/U76	Z	1135.5041.03		M	
2801	0	S		ZE COPROCESSOR COPROCESSOR included in old CMU-B66/U66 replaced by 1135.5041.23	Z	1135.5041.22		M	
2802	0	S		ZE COPROCESSOR COPROCESSOR included in old CMU-B66/U66 replaced by 1135.5041.24	Z	1135.5041.23		M	O
2803	1	S		ZE COPROCESSOR COPROCESSOR included in CMU-B66/U66 replacement for 1135.5041.03/22/23 only in CMU-B66/U66	Z	1135.5041.24		M	O
2804	0	S		ZE COPROCESSOR COPROCESSOR included in old CMU-B68 replaced by 1135.5041.28	Z	1135.5041.08		M	
2805	0	S		ZE COPROCESSOR COPROCESSOR included in old CMU-B68 replaced by 1135.5041.29	Z	1135.5041.28		M	
2806	0	S		ZE COPROCESSOR COPROCESSOR included in old CMU-B68 replaced by 1135.5041.27	Z	1135.5041.29		M	O
2807	1	S		ZE COPROCESSOR COPROCESSOR included in CMU-B68, CMU-U68/MOD04 replacement for 1135.5041.08/28/29	Z	1135.5041.27		M	O
2808	1	S		ZE COPROCESSOR COPROCESSOR included in CMU-B/U78	Z	1135.5041.38		M	O
2809	0	S		PB BEMERKUNG NOTE Attention: For detailed information reg. different variants of modules in options: CMU- B/U66, CMU-B/U68, CMU-B/U76 please see service circular N. 1624!		0999.9610.00		B	O
2810	1	S		EE L1-COPROZESSOR BOARD L1-COPROZESSOR BOARD included in CMU-B/U66, CMU-B68, CMU- B/U76, CMU-B78	Z	1135.5070.03		M	
2820	1	S		EE WCDMATX MODULE WCDMATX MODULE included in old CMU-B/U66,CMU-B68 replaced by 1100.2400.26 included in CMU-B/U76, CMU-B78	Z	1100.2400.02		M	
2821	0	S		EE WCDMATX MODULE WCDMATX MODULE included in old CMU-B/U66,CMU-B68 replaced by 1100.2400.26	Z	1100.2400.22		M	
2822	1	S		EE WCDMATX MODULE WCDMATX MODULE included in CMU-B/U66, CMU-B68	Z	1100.2400.26		M	O



ROHDE & SCHWARZ

Benennung/Designation

**ERSATZTEILE CMU
SPARE PARTS CMU**

Sprach./Lang
de en

Ä.I. / C.I.
18.00

Blatt/Sheet
8 of 12

Dokument Nr. / Document No.

1100.0114.01 ST

Datum/
Date

2006-06-19

Abt. /
Dept.

1CMK

Name /
Name

GL

Für diese Unterlage behalten wir uns alle Rechte vor.
 Ausgedruckte Dokumente unterliegen nicht dem Änderungsdienst.
 For this document all rights are reserved.
 Printed documents are not subject to revision

Pos.-Nr. ItemNo	Menge Quantity	ME Unit	El.Kennz Ref.Des.	Benennung / Bezeichnung Designation	Z	Sachnummer Stock No.	Ersatzteil Subst.part	BA	VH
2830	0	S		ED FEC MODULE FEC MODULE included in old CMU-B/U66,CMU-B68 replaced by 1135.5206.02	Z	1135.5206.22		M	
2831	1	S		ED FEC MODULE FEC MODULE included in CMU-B/U66, CMU-B68, CMU- B/U76, CMU-B78 replacement for 1135.5206.22	Z	1135.5206.02		M	
2832	1	S		ED FEC MODULE FEC MODULE included in CMU-B68 included in CMU-U68/MOD02	Z	1135.5206.23		M	
2833	1	S		ED FEC MODULE FEC MODULE included in CMU-B78 included in CMU-U78/MOD02	Z	1135.5206.33		M	O
2840	1	S		EE WDDC MODULE WDDC MODULE included in CMU-B68 included in CMU-B78 included in CMU-U68/MOD02 included in CMU-U78/MOD02	Z	1135.5329.22		M	
2900	1	S		ZE UNIV.E1/T1 INTERFACE included in CMU-B71 1100.6406.02	Z	1100.6412.02		M	
3000	1	S		GG CTP-B10 ANALOG TEL.INT CTP-B10 ANALOG TEL.INT included in CMU-B73 1150.2004.02	Z	1127.6607.04		M	
3100	1	S		EE LH SER SHORT VAR 03 included in CMU-B76 1100.0601.02 included in CMU-B78 1159.1800.02	Z	1136.0050.02		M	
3300	0	S		EE LINK HANDLER 2 LINK HANDLER 2 included in CMU-B81 1100.6506.02	Z	1100.6606.02		M	
3301	0	S		GR LINK HANDLER CDMA2000 LINKHANDLER included in CMU-B83 1150.0301.02 replaced by 1100.2530.02 included in CMU-U83 1150.0401.02 replaced by 1100.2530.02	Z	1135.6260.00		B	G
3302	1	S		EE CDMA2000 LINK HANDLER CDMA2000 LINK HANDLER included in CMU-B83 1150.0301.12 included in CMU-U83 1150.0401.12	Z	1100.2530.02		M	
3310	1	S		GM ACCESS B. EQU. CMU-B82 ACCESS BOARD EQUIPMENT included in CMU-B82 1150.0201.02	Z	1150.0253.00		B	N
3320	0	S		EE SPEECH CODEC SPEECH CODEC included in CMU-B85 1100.7002.02	Z	1100.7060.02		M	
3321	1	S		EE SPEECH CODEC SPEECH CODED included in CMU-B85 1100.7002.12	Z	1100.7083.02		M	
3325	1	S		ED HDR-MODUL HDR-MODULE included in CMU-B88 1158.9908.02	Z	1158.9950.02		M	
3330	1	S		ZE UNIVERSAL 3GPP2 LH	Z	1159.3049.22		M	



ROHDE & SCHWARZ

Benennung/Designation

**ERSATZTEILE CMU
SPARE PARTS CMU**

Sprach./Lang
de en

Ä.I. / C./
18.00

Blatt/Sheet
9 of 12

Dokument Nr. / Document No.

1100.0114.01 ST

Datum/
Date

2006-06-19

Abt. /
Dept.

1CMK

Name /
Name

GL

Für diese Unterlage behalten wir uns alle Rechte vor.
 Ausgedruckte Dokumente unterliegen nicht dem Änderungsdienst.
 For this document all rights are reserved.
 Printed documents are not subject to revision

Pos.-Nr. ItemNo	Menge Quantity	ME Unit	El.Kennz Ref.Des.	Benennung / Bezeichnung Designation	Z	Sachnummer Stock No.	Ersatzteil Subst.part	BA	VH
3335	1	S		UNIVERSAL 3GPP2 LH included in CMU-B/U83/MOD22 EE UNIVERSAL 3GPP2 LH UNIVERSAL 3GPP2 LH included in CMU-B/U83/MOD22	Z	1159.3055.02		M	O
3340	1	S		ED SPEECH CODEC 3GPP2 SPEECH CODEC 3GPP2 included in CMU-B/U85/MOD22	Z	1159.3555.02		M	O
3350	1	S		EE POWER QUICC III MODUL POWER QUICC III MODUL included in CMU-B/U83/MOD22	Z	1503.1044.25		M	
3355	1	S		DX KABEL CABLE included in CMU-B/U83/MOD22	Z	1159.3032.00		M	
3360	1	S		ED 1XEV-DO MODULE 1XEV-DO MODULE included in CMU-B89 1159.3090.02	Z	1159.3155.02		M	O
3400	1	S		ED AUXTX AUXTX included in CMU-B95 1159.0504.02	Z	1135.9530.04		M	
3500	1	S		ED AUXTX-W AUXTX-W included in CMU-B96 1159.1600.02 included in CMU-U96 1159.3603.02	Z	1135.9860.02		M	
5000	1	S		ZM Geraeterahmen L FRAME Only in combination with motherboard 1100.2352.02 Attention: Old frame 1090.9209.00 fits only with old motherboard 1100.0908.02	Z	1090.9221.00		M	
5001	1	S	E10	ZM LUEFTER BLOWER	Z	1091.1001.00		M	
5002	1	S	E1	ZM LAUTSPRECHER LOUDSPEAKER	Z	1100.0837.00		M	
5010	1	S		KB BESCHRIFTUNGSWANNE FRONT COVER VAR 02	Z	1100.0143.00		M	
5020	1	S		MZ BESCHRIFTUNGSFRONTPLATTE INSCRIPTION PANEL VAR 03	Z	1135.4122.00		M	
5030	1	S		KB BESCHRIFTUNGSWANNE FRONT COVER VAR 10	Z	1100.0608.00		M	
5040	1	S		KB BESCHRIFTUNGSWANNE FRONT COVER VAR 30	Z	1100.0614.00		M	
5050	1	S		KB BESCHRIFTUNGSFRONTPLATTE INSCRIPTION PANEL VAR 53	Z	1135.4145.00		M	
5060	1	S		MZ BW2-TUBUS BW2-TUBUS	Z	1100.0743.00		M	
5061	1	S		KR BW2-FRONTGRIFF 4E FRONT HANDLE		1096.1480.00		B	T
5062	1	S		VS SCHR. M4X14-ISR-PA SCREW M4X14-ISR-PA		1096.4896.00		B	T
5063	1	S		KR BW2-RUECKWANDFUSS 50MM		1096.2493.00		B	O



ROHDE & SCHWARZ

Benennung/Designation

**ERSATZTEILE CMU
SPARE PARTS CMU**

Sprach./Lang
de en

Ä.I. / C.I
18.00

Blatt/Sheet
10 of 12

Dokument Nr. / Document No.

1100.0114.01 ST

Datum/
Date

2006-06-19

Abt. /
Dept.

1CMK

Name /
Name

GL

Für diese Unterlage behalten wir uns alle Rechte vor.
 Ausgedruckte Dokumente unterliegen nicht dem Änderungsdienst.
 For this document all rights are reserved.
 Printed documents are not subject to revision

Pos.-Nr. ItemNo	Menge Quantity	ME Unit	El.Kennz Ref.Des.	Benennung / Bezeichnung Designation	Z	Sachnummer Stock No.	Ersatzteil Subst.part	BA	VH
5064	1	S		REAR WALL FOOT KR BW2-GERAETEFUSS FOOT		1096.2506.00		B	O
5065	1	S		KR BW2-AUFSTELLFUSS FOOT		1096.2529.00		B	O
5066	1	S		KR BW2-ABDECKUNG SEITLICH COVER LATERALLY		1096.2558.00		B	T
5067	1	S		KR BW2-STAHLBAND T450		1096.2729.00		M	T
5068	1	S		KR BW2-SCHLAUCH T450		1096.2770.00		M	T
5069	1	S		KR BW2-HALTER BW2-HOLDER		1096.2829.00		B	T
6000	0	S		PB BEMERKUNG NOTE The following cables are shown in 1100.0872.00		0999.9610.00		B	O
6005	1	S	W5	DV HF-KABEL CMU200 RF-CABLE	Z	1100.3894.00		M	
6006	1	S	W6	DV HF-KABEL RF-CABLE	Z	1100.3907.00		M	
6007	1	S	W7	DV HF-KABEL RF-CABLE	Z	1100.3913.00		M	
6008	1	S	W8	DV HF-KABEL RF-CABLE	Z	1100.3920.00		M	
6012	1	S	W12	DV HF KABEL RF CABLE	Z	1100.3965.00		M	
6013	1	S	W13	DW HF-KABEL RF-CABLE	Z	1100.3971.00		M	
6014	1	S	W14	DW HF-KABEL RF-CABLE	Z	1100.3988.00		M	
6017	1	S	W17	DV HF KABEL RF CABLE	Z	1100.4010.00		M	
6018	1	S	W18	DV HF KABEL RF CABLE	Z	1100.4026.00		M	
6019	1	S	W19	DV HF KABEL RF CABLE	Z	1100.4032.00		M	
6021	1	S	W21	DV HF KABEL W21 RF CABLE W21	Z	1100.6041.00		M	
6022	1	S	W22	DV HF KABEL W22 RF CABLE W22	Z	1100.6058.00		M	
6031	1	S	W31	DV HF KABEL RF CABLE	Z	1100.4155.00		M	
6032	1	S	W32	DV HF-KABEL RF CABLE	Z	1100.4161.00		M	
6033	1	S	W33	DV HF-KABEL RF CABLE	Z	1100.4178.00		M	
6035	1	S	W35	DV HF KABEL RF CABLE	Z	1100.4190.00		M	
6036	1	S	W36	DV HF KABEL RF CABLE	Z	1100.4203.00		M	



ROHDE & SCHWARZ

Benennung/Designation
ERSATZTEILE CMU
SPARE PARTS CMU

Sprach./Lang
de en

Ä.I. / C.I.
18.00

Blatt/Sheet
11 of 12

Dokument Nr. / Document No.

1100.0114.01 ST

Datum/
Date

2006-06-19

Abt. /
Dept.

1CMK

Name /
Name

GL

Für diese Unterlage behalten wir uns alle Rechte vor.
Ausgedruckte Dokumente unterliegen nicht dem Änderungsdienst.
For this document all rights are reserved.
Printed documents are not subject to revision

Pos.-Nr. ItemNo	Menge Quantity	ME Unit	El.Kennz Ref.Des.	Benennung / Bezeichnung Designation	Z	Sachnummer Stock No.	Ersatzteil Subst.part	BA	VH
6037	1	S	W37	DV HF KABEL RF CABLE	Z	1100.4210.00		M	
6040	1	S	W40	DV HF-KABEL RF-CABLE	Z	1100.3665.00		M	
6096	1	S	W96	DV HF KABEL RF CABLE	Z	1135.9653.00		M	
6097	1	S	W97	DV HF KABEL RF CABLE	Z	1135.9647.00		M	
6098	1	S	W98	DV HF KABEL RF CABLE	Z	1135.9599.00		M	
6099	1	S	W99	DV HF Kabel RF CABLE	Z	1135.9582.00		M	
6502	1	S	W502	DV HF-KABEL RF-CABLE	Z	1135.4300.00		M	
6513	1	S	W513	DV HF-KABEL RF-CABLE	Z	1135.4316.00		M	
6514	1	S	W514	DV HF-KABEL RF-CABLE	Z	1135.4322.00		M	
6515	1	S	W515	DV HF-KABEL RF-CABLE	Z	1135.4339.00		M	
6516	1	S	W516	DV HF-KABEL RF-CABLE	Z	1135.4345.00		M	
6518	1	S	W518	DV HF-KABEL RF-CABLE	Z	1135.4351.00		M	
6520	1	S	W520	DV HF-KABEL RF-CABLE	Z	1135.4368.00		M	
6521	1	S	W521	DV HF-KABEL RF-CABLE	Z	1135.4380.00		M	
6522	1	S	W522	DV HF-KABEL RF-CABLE	Z	1135.4380.00		M	
6901	1	S	W901	DV HF-KABEL RF-CABLE	Z	1149.9550.00		M	
6913	1	S	W913	DV HF KABEL FR CABLE	Z	1149.9880.00		M	
6914	1	S	W914	DV HF KABEL RF CABLE	Z	1149.9896.00		M	
6923	1	S	W923	DV HF-KABEL RF-CABLE	Z	1149.9573.00		M	
6924	1	S	W924	DV HF-KABEL RF-CABLE	Z	1149.9567.00		M	
6961	1	S	W961	DV KABEL W961 CABLE W961	Z	1159.1698.00		M	
6962	1	S	W962	DX KABEL W962 CABLE W962	Z	1159.1700.00		M	



ROHDE & SCHWARZ

Benennung/Designation
ERSATZTEILE CMU
SPARE PARTS CMU

Sprach./Lang
de en

Ä.I. / C.I
18.00

Blatt/Sheet
12 of 12

Dokument Nr. / Document No.

1100.0114.01 ST

Datum/
Date 2006-06-19

Abt. /
Dept. 1CMK

Name /
Name GL



Drawings of all

CMU Modules

I

B

C

D

E

F

G

H

I

J

K

L

Für dieses Dokument behalten wir uns alle Rechte vor.
For this document all rights are reserved.

Projektions-
methode
Projection
Method

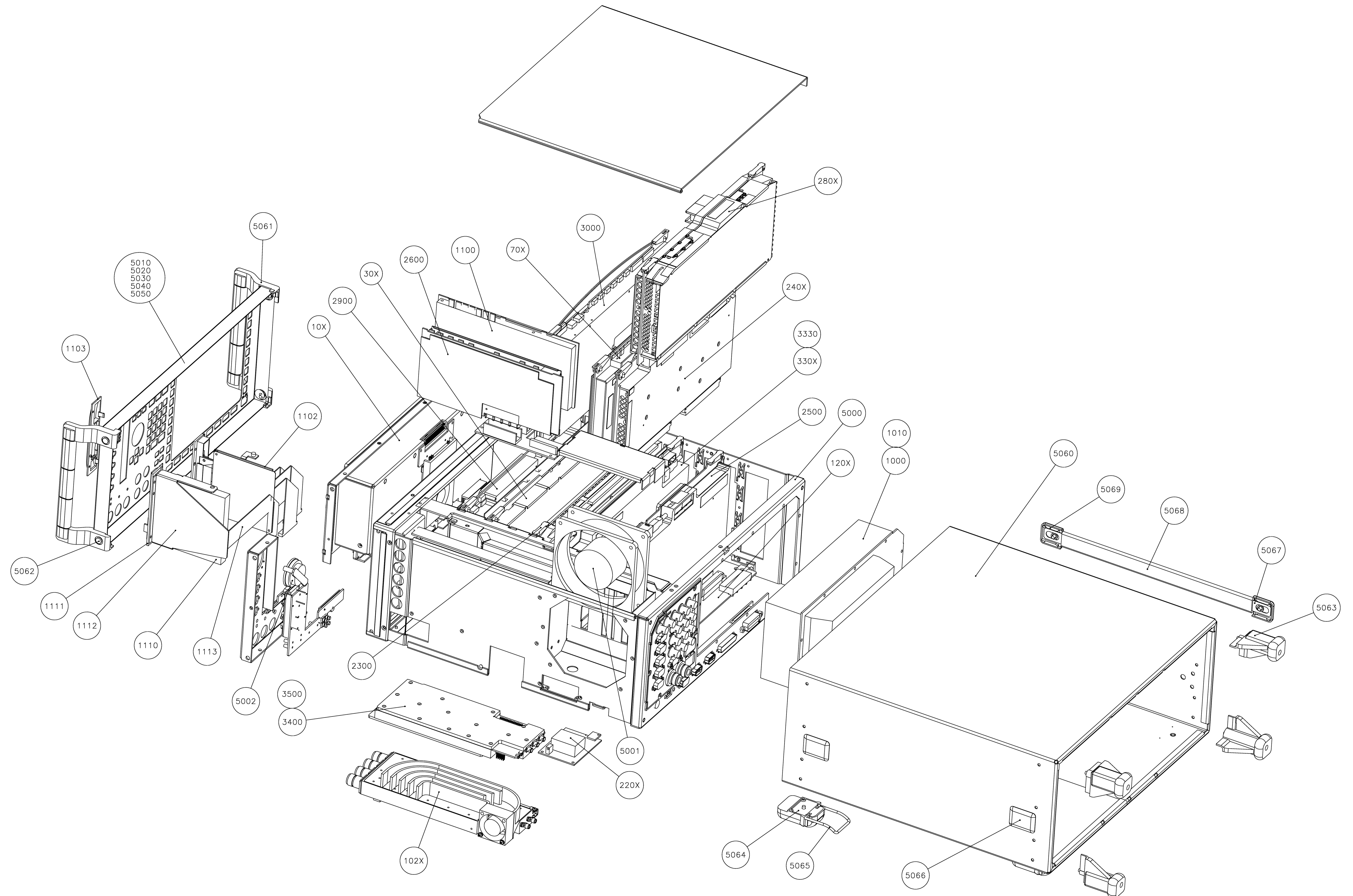

Skizzen-Nr. / Drawing No.	1100.0008.01	Blatt / Sh.	2
Version	1	Scale	1:1
Proj. / Proj.	1CMK	Rev. / Rev.	bi
Design Date	2006-05-15	Abteilung / Dept.	15
Objekt / Object	CMU200	Werkstoff / Material	
Bezeichnung / Designation	CMU200 UNIV.RADIOCOM.	Sprache / Lang.	de en
Zeichner / Designer		Verf. / Ver.	

Für diese Zeichnung behalten wir uns alle Rechte vor.
Diese Zeichnung ist ein Rechneerausdruck, Änderungen können nur durch ändern des Datensatzes erfolgen.

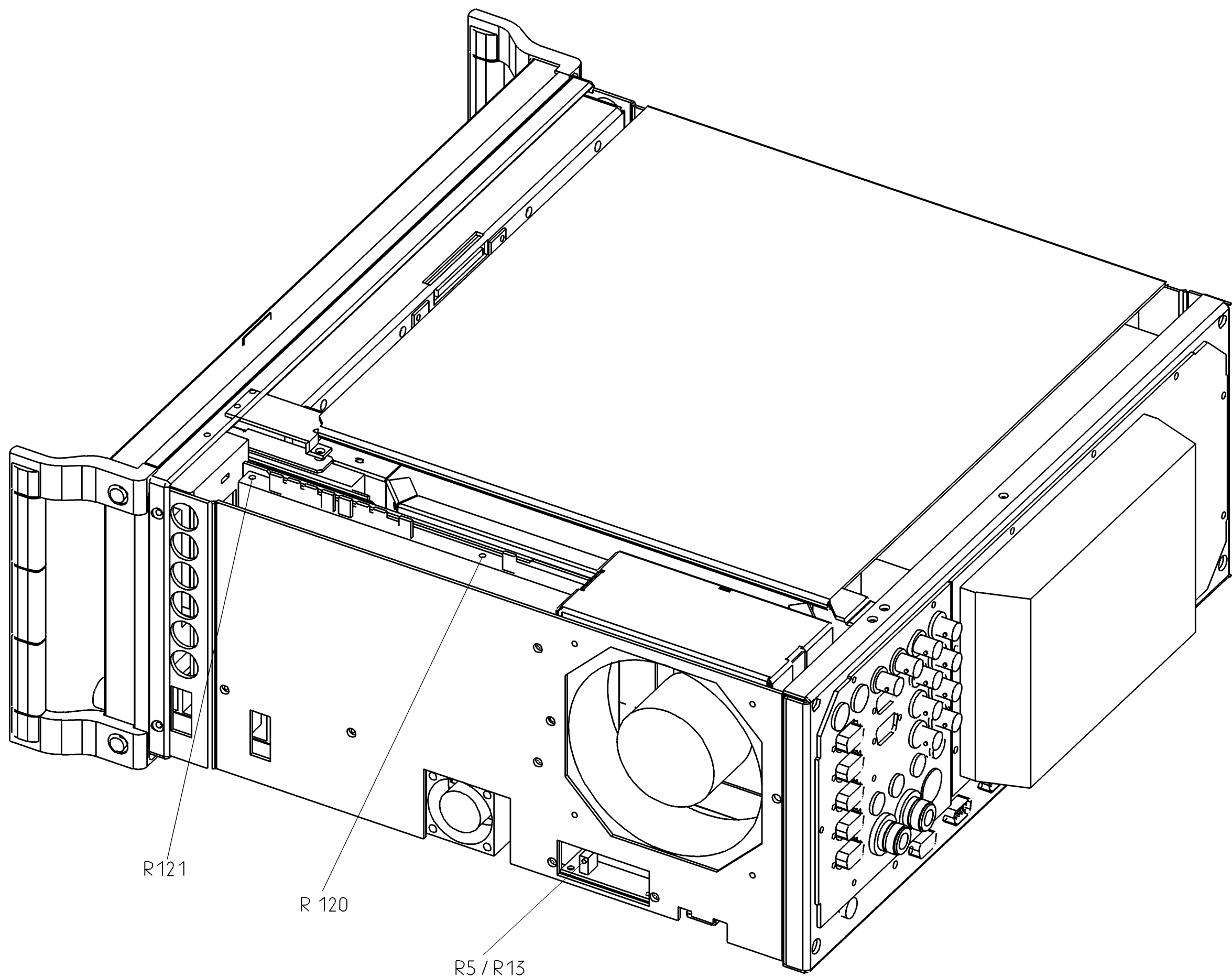

06.00				1CMK	Datum	Name
				Bearb.	03.05.99	Bi
				Gepr.		
Änd. Index	Änderungs-Mitteilung	Datum	Name	Norm		
				Plot		

ROHDE&SCHWARZ
 zu Gerät

Benennung
GG CMU200 UNIV.RADIOCOM.

Zeichn.-Nr.	Blatt-Nr.
1100.0008.01	3
regi.V.	v. Bl.
erste Z.	

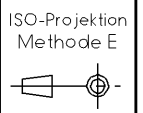

ISO-Projektion
 Methode E

Für dieses Dokument behalten wir uns alle Rechte vor
 For this document all rights are reserved

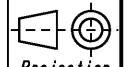
Projektions-
 methode

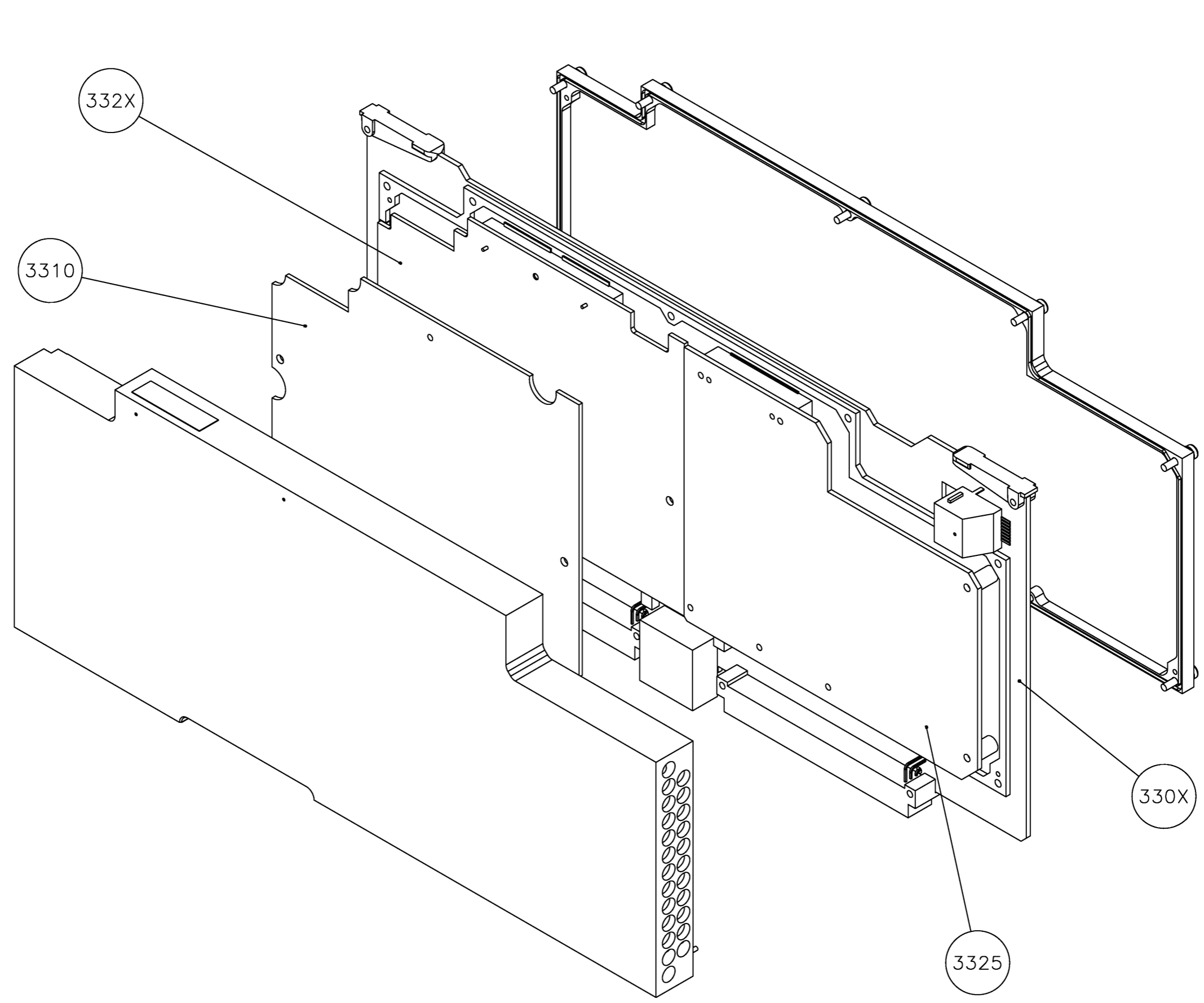
 Projection
 Method



only for MOD 02/12

Maßstab Scale	Toleranz Tol.	Werkstoff Material	Sprache / Lang. / Aei. / C.I.		Blatt / Sh.
ROHDE&SCHWARZ	Benennung / Designation CMU-B83 CDMA2000 SIGNA CMU-B83		de en	10.00	1
Datum Date	05.05.2003	Abteilung Dept.	1CMK	Name Name	Bi
			Zeichn.Nr. / Drawing No.		
			1150.0301.01		D

Für dieses Dokument behalten wir uns alle Rechte vor
 For this document all rights are reserved

Projektions-
 methode
 Projection
 Method

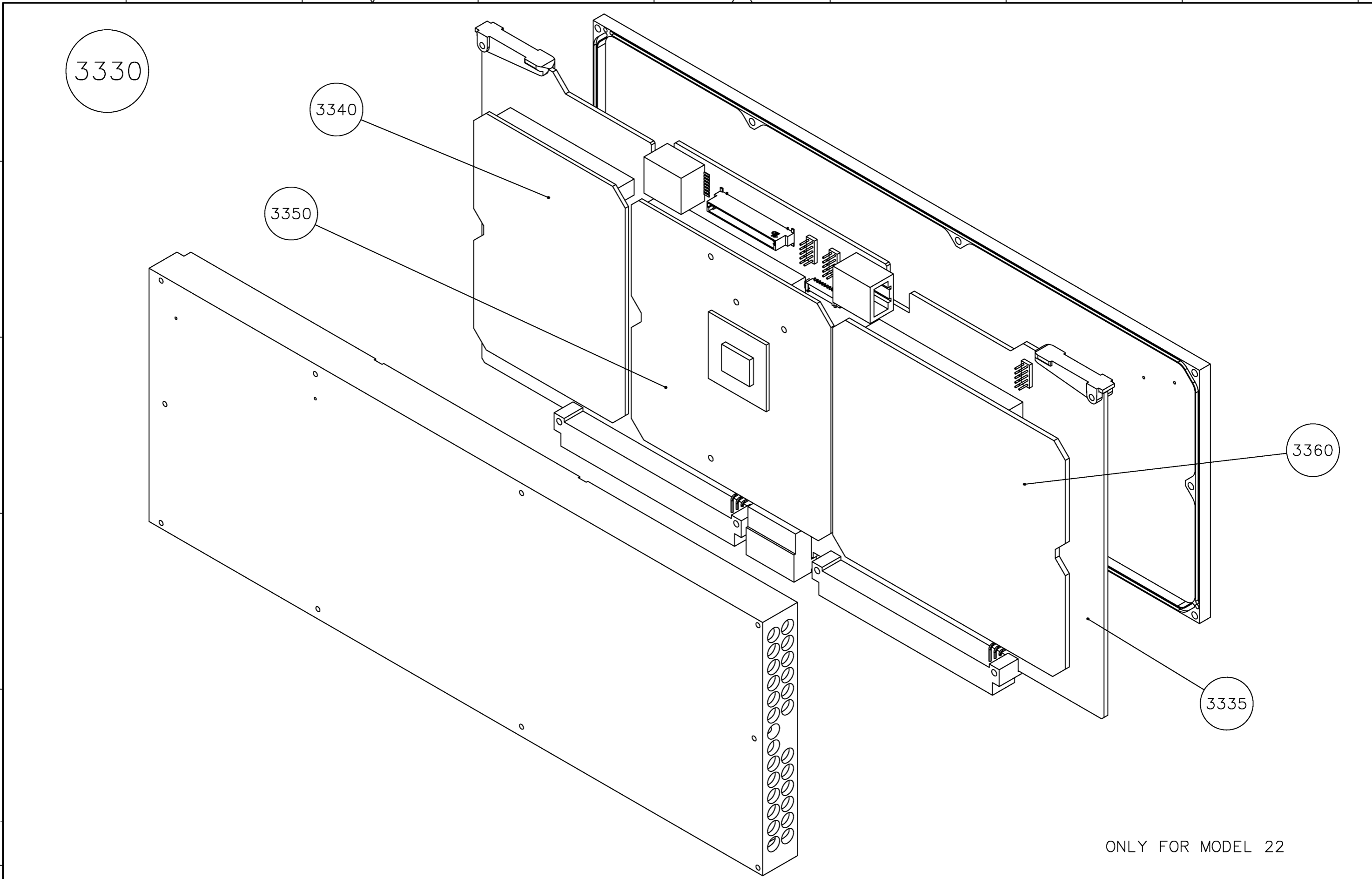

ONLY FOR MODEL 22

Maßstab Scale	Toleranz Tol.	Werkstoff Material	Sprache / Lang. / Aei. / C.I.		Blatt / Sh.
ROHDE&SCHWARZ	Benennung / Designation	CMU-B83 CDMA2000 SIGNA CMU-B83	de en	10.00	2
CMU-B83	Datum Date	2006-05-12	Abteilung Dept.	1CMK	Name Name
			bi		Zeichn.Nr. / Drawing No.
					1150.0301.01 D

Bestückungsvarianten ZE Coprozessor 1135.5041.xx

CMU-B66/U66 Basisausführung			CMU-B66/U66 Ausf. Spar-WTX und Spar-TX-FEC			CMU-B66/U66 Ausf. nur Spar-WTX			CMU-B66/U66 Ausf. mit WTX-2ZF (B96)		
Board	El.Kz.	Mat.-Nr.	Board	El.Kz.	Mat.-Nr.	Board	El.Kz.	Mat.-Nr.	Board	El.Kz.	Mat.-Nr.
WTX	A920	1100.2400.02	WTX	A920	1100.2400.22	WTX	A920	1100.2400.22	WTX	A920	1100.2400.26
TX-FEC	A940	1135.5206.02	TX-FEC	A940	1135.5206.22	TX-FEC	A940	1135.5206.02	TX-FEC	A940	1135.5206.02
RX-FEC	A930	-----	RX-FEC	A930	-----	RX-FEC	A930	-----	RX-FEC	A930	-----
WDDC	A910	-----	WDDC	A910	-----	WDDC	A910	-----	WDDC	A910	-----
Copro.	A900	1135.5070.03	Copro.	A900	1135.5070.03	Copro.	A900	1135.5070.03	Copro.	A900	1135.5070.03
ZE Cop.		1135.5041.03	ZE Cop.		1135.5041.22	ZE Cop.		1135.5041.23	ZE Cop.		1135.5041.24

CMU-B68 Basisausführung			CMU-B68 Ausf. Spar-WTX und Spar-TX-FEC			CMU-B68 Ausf. nur Spar-WTX			CMU-B68 Ausf. mit WTX-2ZF (B96)		
Board	El.Kz.	Mat.-Nr.	Board	El.Kz.	Mat.-Nr.	Board	El.Kz.	Mat.-Nr.	Board	El.Kz.	Mat.-Nr.
WTX	A920	1100.2400.02	WTX	A920	1100.2400.22	WTX	A920	1100.2400.22	WTX	A920	1100.2400.26
TX-FEC	A940	1135.5206.02	TX-FEC	A940	1135.5206.22	TX-FEC	A940	1135.5206.02	TX-FEC	A940	1135.5206.02
RX-FEC	A930	1135.5206.23	RX-FEC	A930	1135.5206.23	RX-FEC	A930	1135.5206.23	RX-FEC	A930	1135.5206.23
WDDC	A910	1135.5329.22	WDDC	A910	1135.5329.22	WDDC	A910	1135.5329.22	WDDC	A910	1135.5329.22
Copro.	A900	1135.5070.03	Copro.	A900	1135.5070.03	Copro.	A900	1135.5070.03	Copro.	A900	1135.5070.03
ZE Cop.		1135.5041.08	ZE Cop.		1135.5041.28	ZE Cop.		1135.5041.29	ZE Cop.		1135.5041.27

CMU300-WCDMA CMU-B76/U76 Basisausführung			CMU300-WCDMA CMU-B76/U76 Geplante Sparausf.			CMU300-WCDMA CMU-B78 Basisausführung		
Board	El.Kz.	Mat.-Nr.	Board	El.Kz.	Mat.-Nr.	Board	El.Kz.	Mat.-Nr.
WTX	A920	1100.2400.02	WTX	A920	1100.2400.32	WTX	A920	1100.2400.02
TX-FEC	A940	1135.5206.02	TX-FEC	A940	1135.5206.32	TX-FEC	A940	1135.5206.02
RX-FEC	A930	-----	RX-FEC	A930	-----	RX-FEC	A930	1135.5206.33
WDDC	A910	-----	WDDC	A910	-----	WDDC	A910	1135.5329.22
Copro.	A900	1135.5070.03	Copro.	A900	1135.5070.22	Copro.	A900	1135.5070.03
ZE Cop.		1135.5041.03	ZE Cop.		1135.5041.32	ZE Cop.		1135.5041.38

CRTU-W Vollausführung, nur f. E-Muster !!!			CRTU-W Grundauf. ab 1. Kundenserie		
Board	El.Kz.	Mat.-Nr.	Board	El.Kz.	Mat.-Nr.
WTX	A920	1100.2400.02	WTX	A920	1100.2400.02
TX-FEC	A940	1135.5206.02	TX-FEC	A940	1135.5206.12
RX-FEC	A930	1135.5206.03	RX-FEC	A930	1135.5206.13
WDDC	A910	1135.5329.02	WDDC	A910	1135.5329.02
Copro.	A900	1135.5070.02	Copro.	A900	1135.5070.12
ZE Cop.		-----	ZE Cop.		1135.5041.02

280X

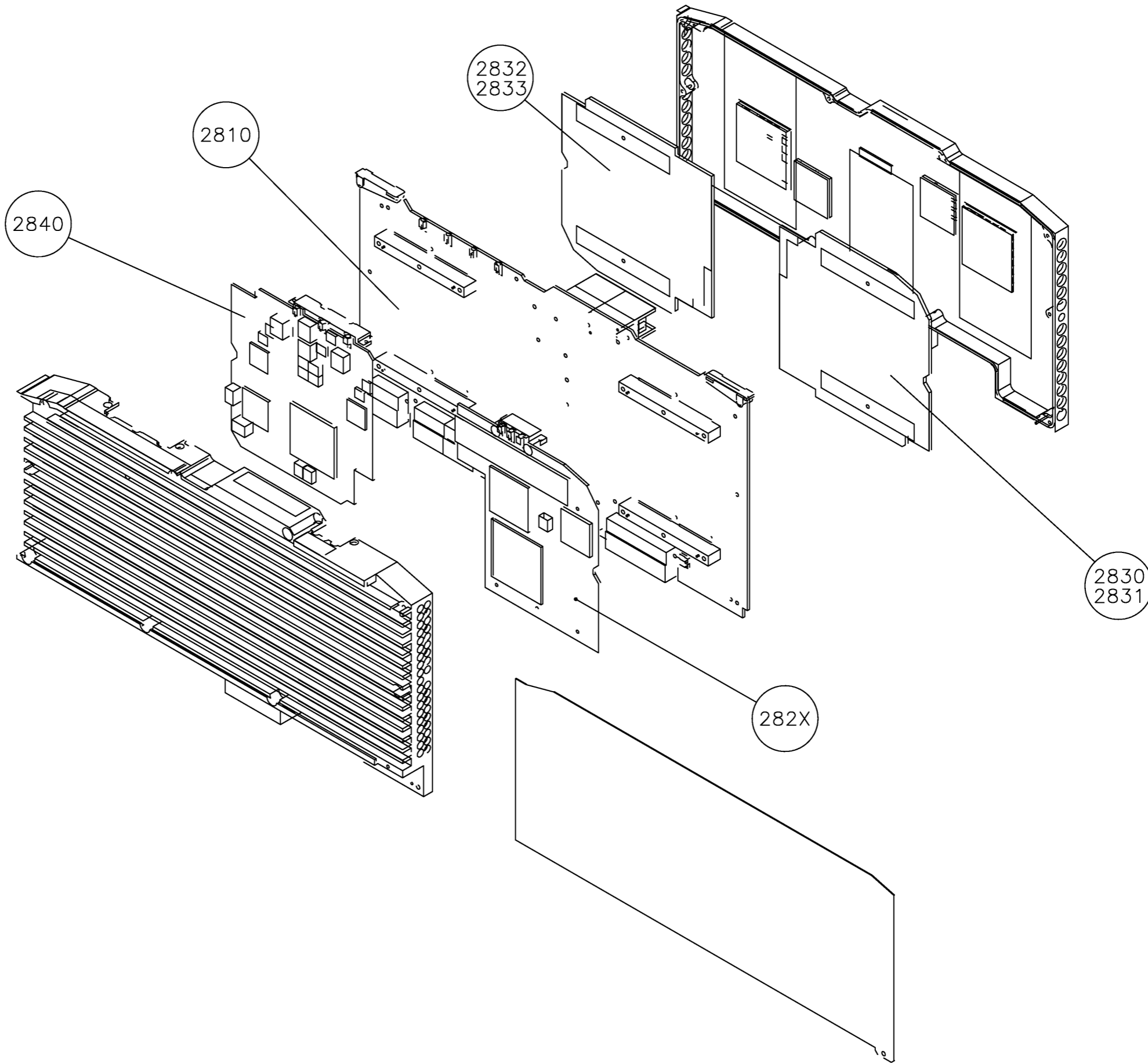

Für dieses Dokument behalten wir uns alle Rechte vor
For this document all rights are reserved

Projektions-
methode
Projection
Method

Maßstab Scale	Toleranz Tol.	Arbeitsstoff Material		Sprache / Lang. / Axi. / C.I.	Blatt / Sh.
ROHDE&SCHWARZ	Benennung / Designation	COPROCESSOR		de en 15.00	4
Typ Type	Datum Date	Abteilung Dept.	Name Name	Zeichn.Nr. / Drawing No.	
1. Z. used in	19.07.2002	1CMK	Fg	1135.5041.01	D

70X

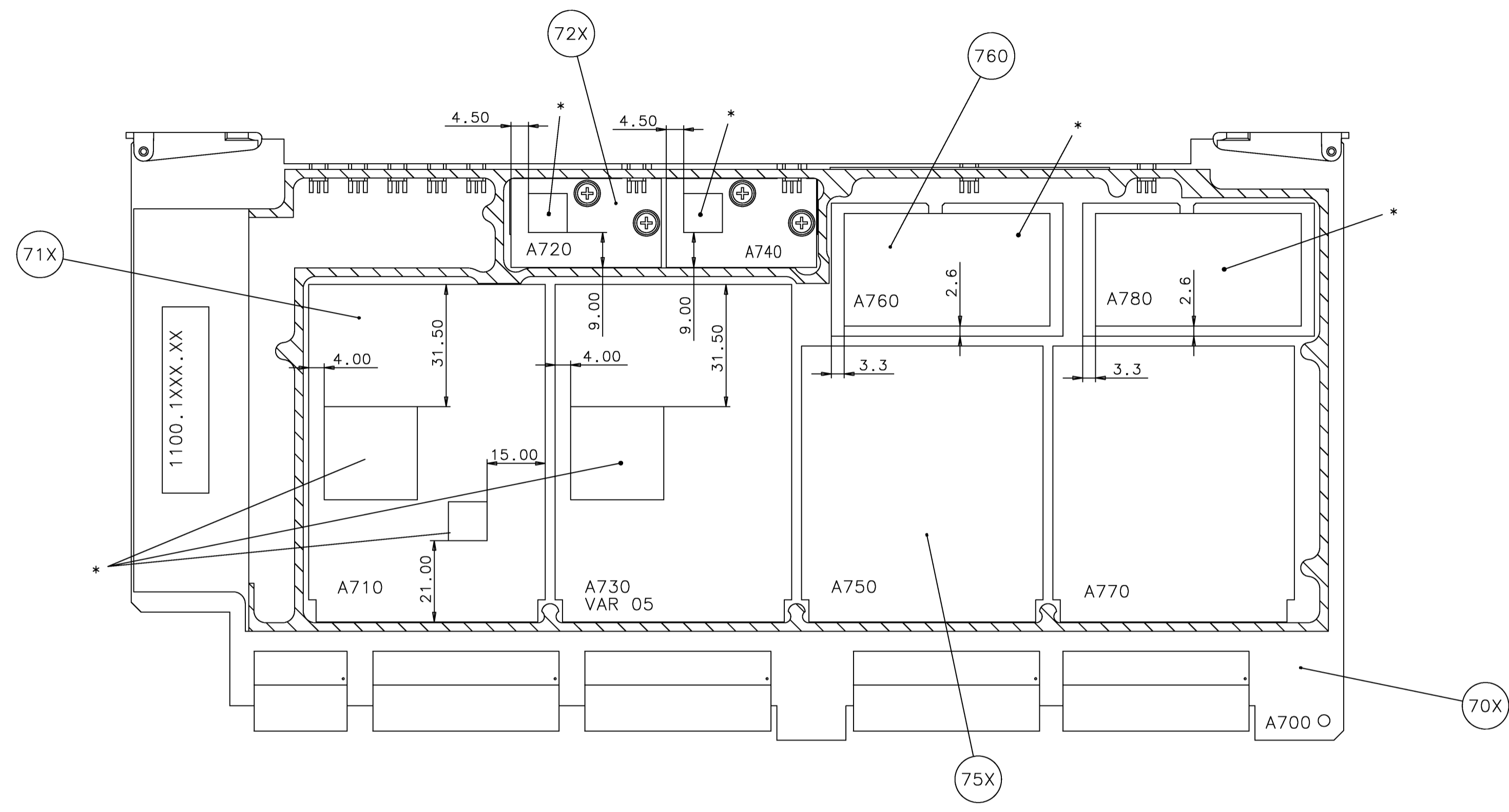

* Affix the supplied heat conducting mat with its adhesive side to the sandwich module as shown

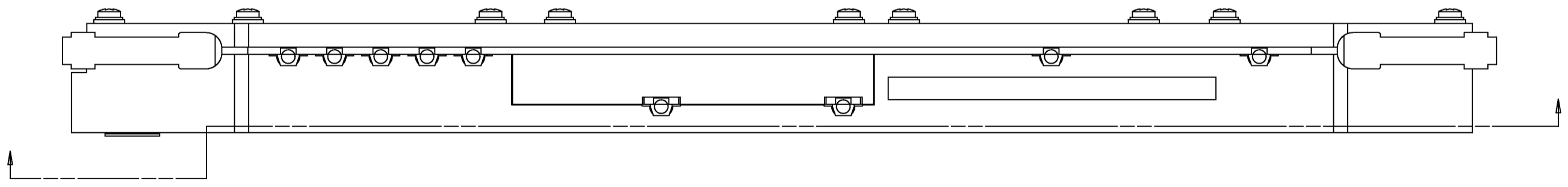

Für dieses Dokument behalten wir uns alle Rechte vor
For this document all rights are reserved

Projektions-
methode
Projection
Method

Maßstab Scale	Toleranz Tol.	Werkstoff Material	Sprache / Lang. / Ael. / C.I.	Blatt / Sh.
ROHDE&SCHWARZ	Benennung / Designation	DIGITALTEIL 2 DIGITAL UNIT 2	de en 01.00	2
Datum Date	Abteilung Dept.	Name	Zeichn.Nr. / Drawing No.	
03.03.2004	1CMK	Bi	1100.1940.01 D	

30X

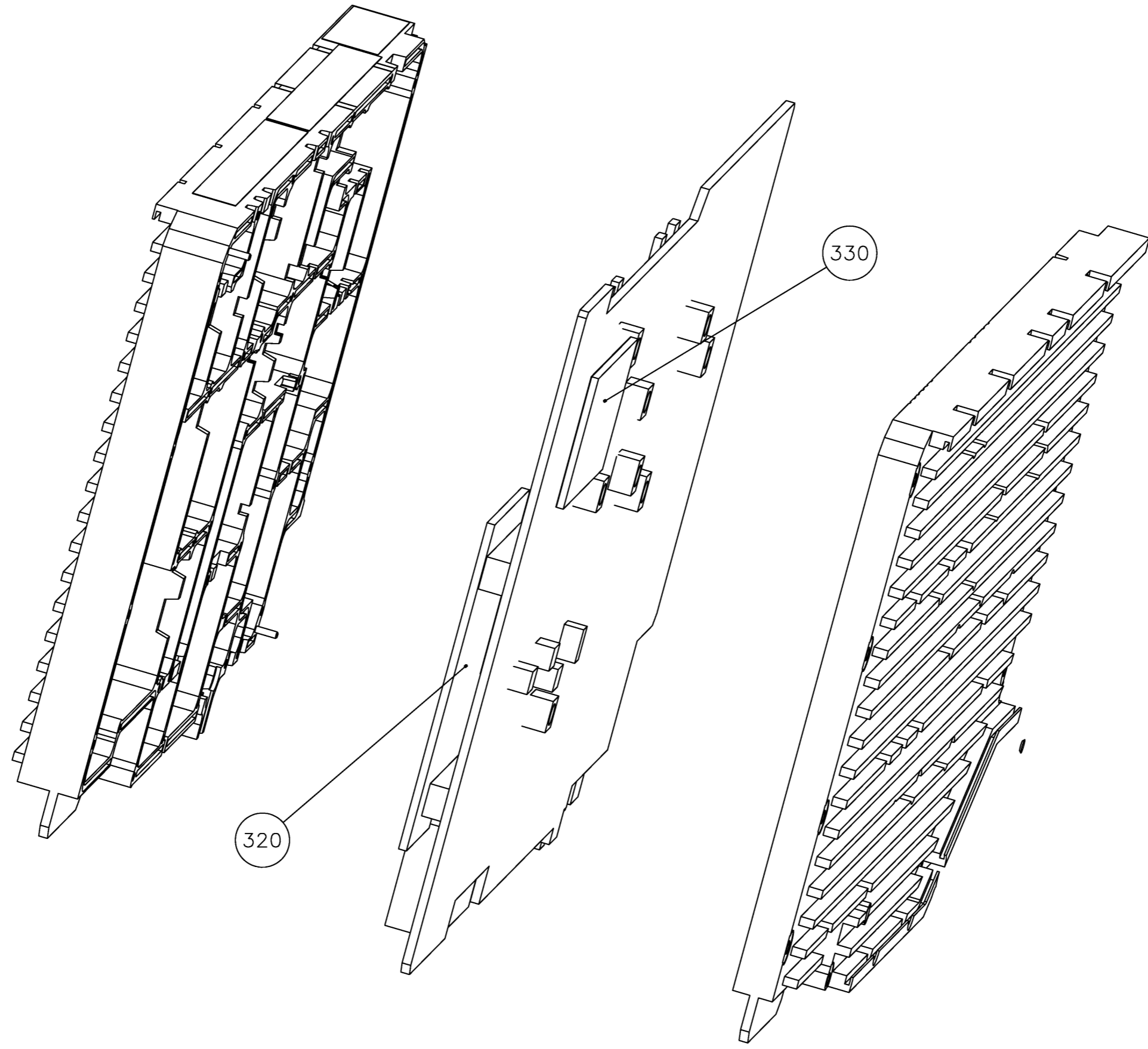

Für dieses Dokument behalten wir uns alle Rechte vor
For this document all rights are reserved

Projektions-
methode
Projection
Method

Maßstab Scale	Toleranz Tol.	Werkstoff Material		Sprache / Lang.	Verf. / C.I.	Blatt / Sh.
ROHDE&SCHWARZ	Benennung / Designation	RX/TX BOARD RX/TX BOARD		de en	14.00	3
CMU	Datum Date	2006-05-11	Abteilung Dept.	1CMK	Name Name	bi
				Zeichn.Nr. / Drawing No.		1135.6925.01 D

Für dieses Dokument behalten wir uns alle Rechte vor
 For this document all rights are reserved
 Projektionsmethode
 Projection Method

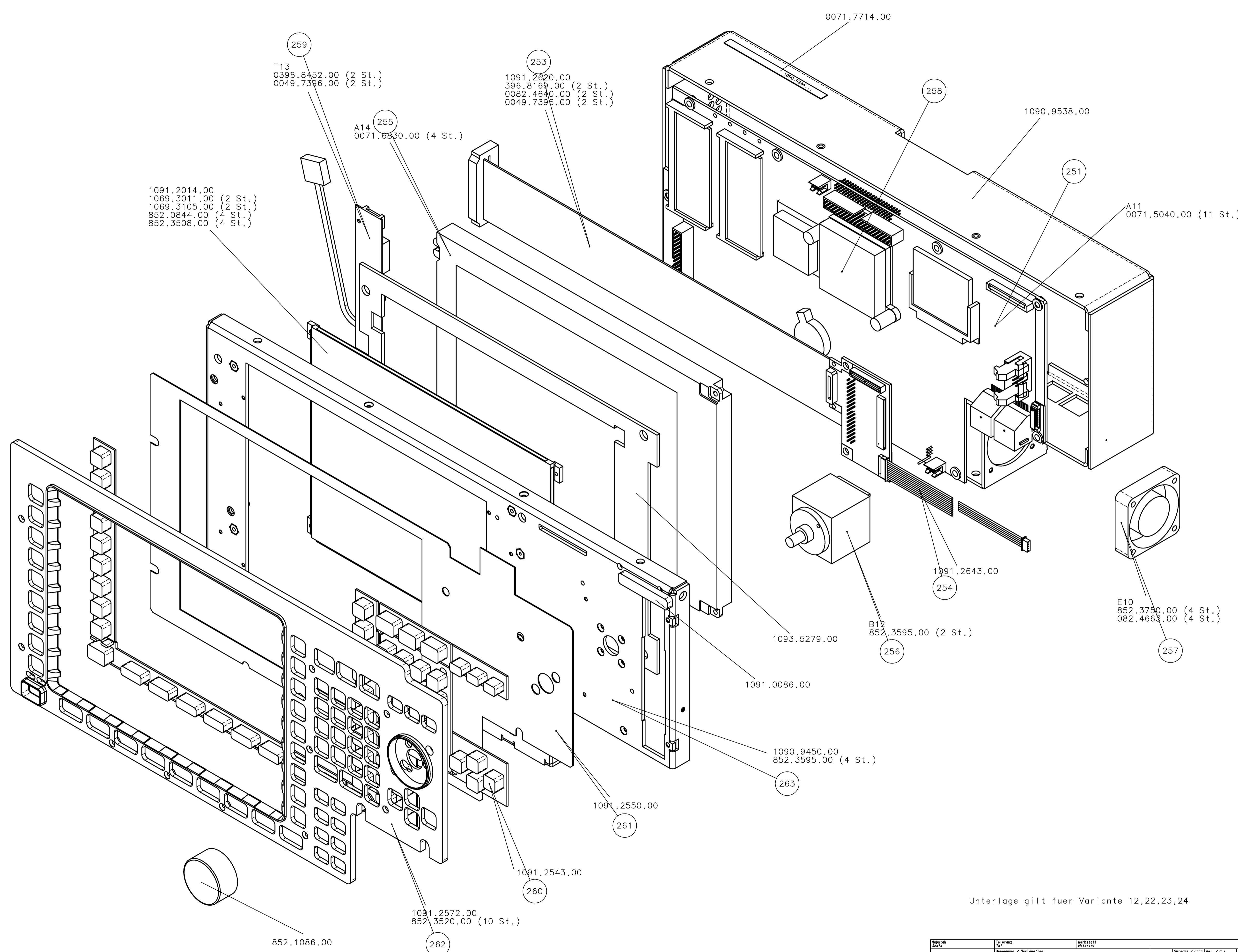

Unterlage gilt fuer Variante 12,22,23,24

Hersteller ROHDE & SCHWARZ	Teilanz. Bezeichnung / Designation FRONTMODUL	Werkstoff Material	Sprache / Lang. de en	Blatt / von 41.00 / 3
Typ PSP	Zeichn.-Nr. / Drawing No. 1090.9244.01			
U.S. used in	Stichtag 19.03.2001	Abteilung 1CMK	Name Bi	

250X

256X

2540

2550

2510

2530

2520

Für dieses Dokument behalten wir uns alle Rechte vor
For this document all rights are reserved

Projektions-
methode
Projection
Method

Maßstab Scale	Toleranz Tol.	Werkstoff Material		
ROHDE&SCHWARZ	Benennung / Designation	UNIVERS. SIGN. UNIT		Sprache / Lang. / Aei. / C.I.
		UNIVERS. SIGN. UNIT		de en 02.00 2
CMU	Datum Date	2006-05-11	Abteilung Dept.	1CMK
	Name Name	bi		Zeichn.Nr. / Drawing No.
				1135.4497.01 D

2600

2430

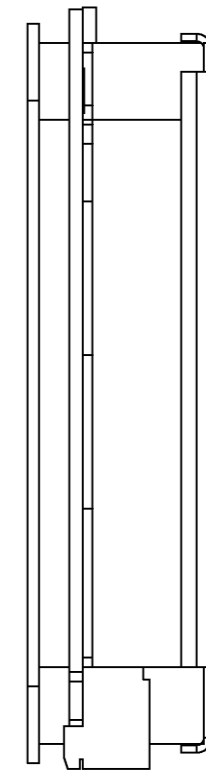
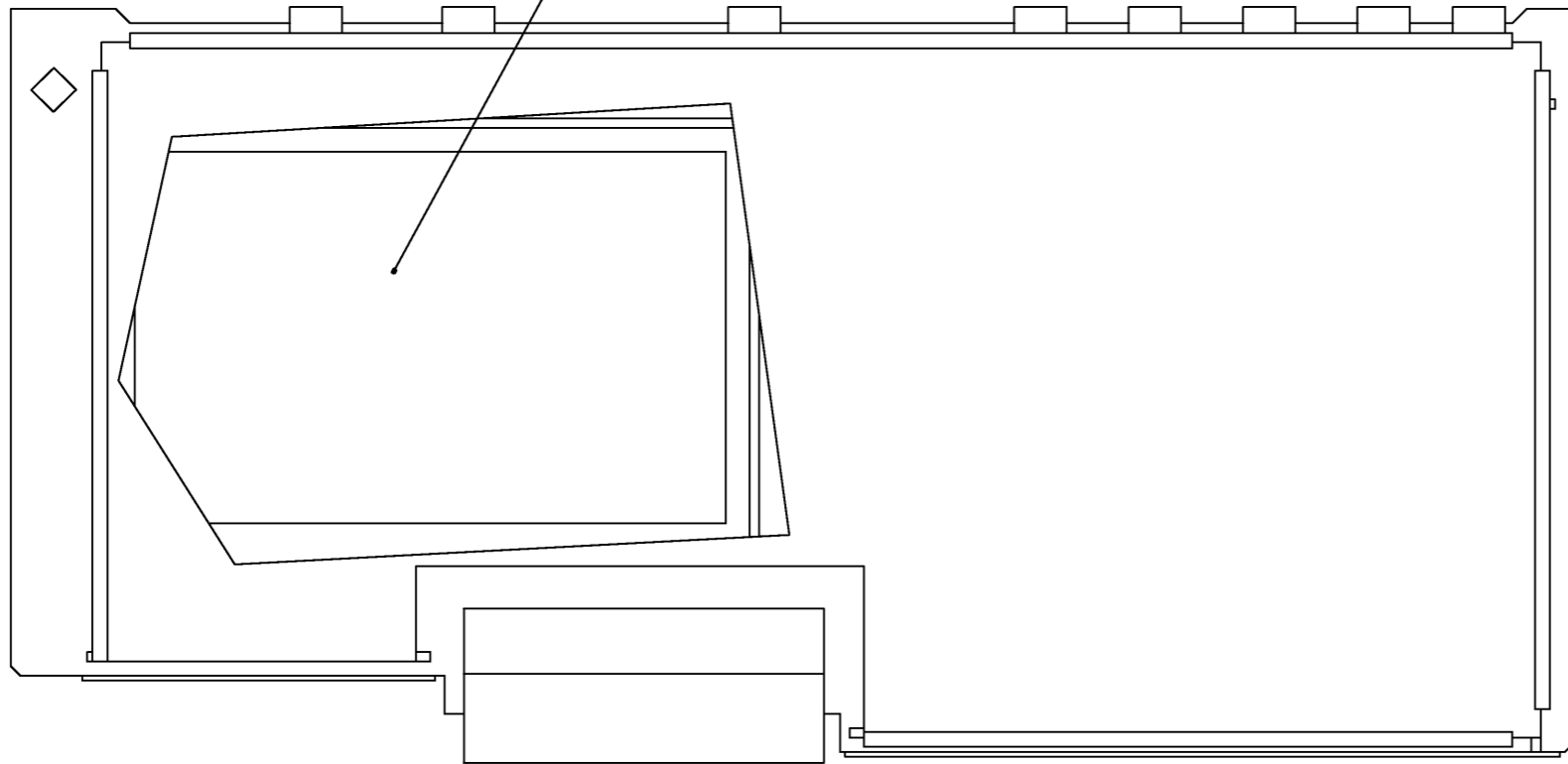

Für dieses Dokument behalten wir uns alle Rechte vor
For this document all rights are reserved

Projektions-
methode
Projection
Method

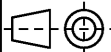

Maßstab Scale	Toleranz Tol.	Werkstoff Material	Sprache / Lang. / Axi. / C.I.		Blatt / Sh.
ROHDE&SCHWARZ	Benennung / Designation	AUDIO BOARD		de en	04.00
CMU	Datum Date	2006-05-11	Abteilung Dept.	1CMK	Name Name
				bi	1100.2800.01
					D

Für dieses Dokument behalten wir uns alle Rechte vor.
For this document all rights are reserved

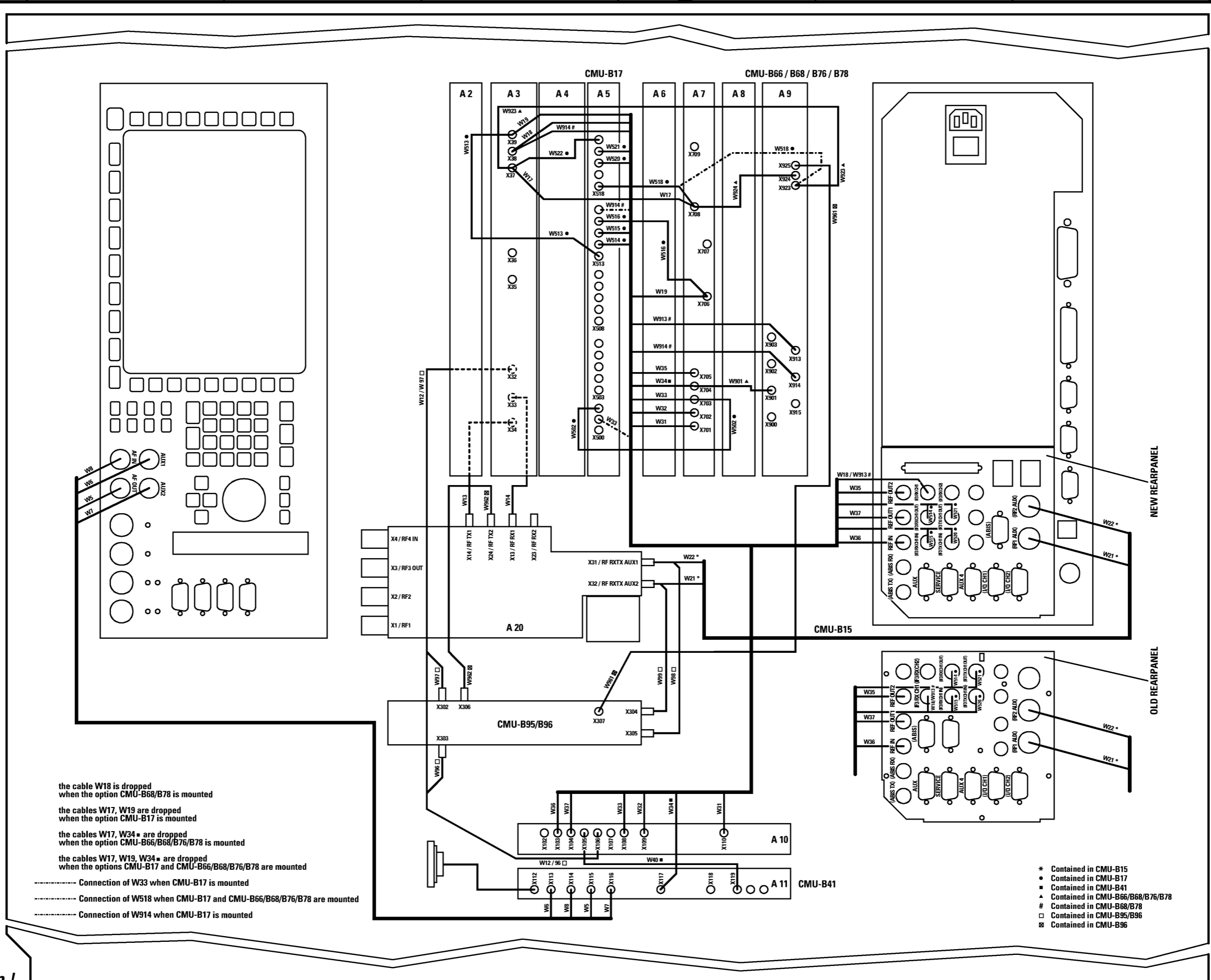

the cable W18 is dropped when the option CMU-B68/B78 is mounted

the cables W17, W19 are dropped when the option CMU-B17 is mounted

the cables W17, W34 are dropped when the option CMU-B66/B68/B76/B78 is mounted

the cables W17, W19, W34 are dropped when the options CMU-B17 and CMU-B66/B68/B76/B78 are mounted

----- Connection of W33 when CMU-B17 is mounted

----- Connection of W518 when CMU-B17 and CMU-B66/B68/B76/B78 are mounted

----- Connection of W914 when CMU-B17 is mounted

- * Contained in CMU-B15
- Contained in CMU-B17
- ▲ Contained in CMU-B41
- ▲ Contained in CMU-B66/B68/B76/B78
- # Contained in CMU-B68/B78
- Contained in CMU-B95/B96
- ⊗ Contained in CMU-B96

auf Lage achten !

Beschriftung: tiefschwarz RAL 9005 (WU 002.2823)
hierzu Druckvorlage 1100.0872 DV -14-
bearbeitet aus 1091.0657.00

Maßstab: Scale: 1:1	Toleranz: Tol.:	Werkstoff: Material:	Sprache / Lang.: / Aei. / C.I.:		Blatt / Sh.:
ROHDE & SCHWARZ	Benennung: Designation:	Deckel (bedr.)		de	14.00
Typ: Type: CMU	Datum: Date: 11.98	Abteilung: Dept.: 1CMK	Name: Name: Bi	1	
1. Z.: used in: 1100.0008.01	Zeichn. Nr.: / Drawing No.:		1100.0872.00		

1100.0872 DV -14- Deckel (bedr.) 1CMK/No. 11.98 09 ----- 09.01 Wb 10 ----- 01.03 Wb 11 ----- 09.03 Kg -12- 2005-03 Wb
13- 2005-08 Wb -14- 2005-08 Wb

Projektions-
methode

Projektions-
Method

TEXTEN
KASCHIERUNG
FEHLEN

DARSTELLUNG SEITE B
VIEW ON SIDE B

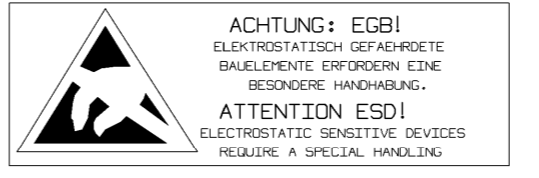

ACHTUNG: ESD!
ELEKTROSTATISCH GEFÄHRDete
BAUELEMENTE ERFOEDERN EINE
BESONDERE HANDLUNG.
ATTENTION ESD!
ELECTROSTATIC SENSITIVE DEVICES
REQUIRE A SPECIAL HANDLING.

BEZUGS-ANGABEN LIEFERN VARIANTEN,
TRIMMWERTE, BAUELEMENTE UND
NICHT BESTRIECKTE BAUTEILE SEHE SA.
FOR BINDING INFORMATION ON MODELS,
TRIMMING AND COMPONENTS VALUES AND
NONFITTED COMPONENTS SEE PARTS LIST.

09.01					10MK	DATUM	NAME	BENENNUNG
					BEARB.		KR	MOTHERBOARD
					GEPR.		KR	
					NDRM			
					PLOTT	08-11-30	GROLL	
								ZEICHN.-NR.
								1100.1027.01 D
								REG. I.W. 1100.0008
								ERSTE Z. 1100.0008
								BLATT-NR.
								1+
								V. BL.

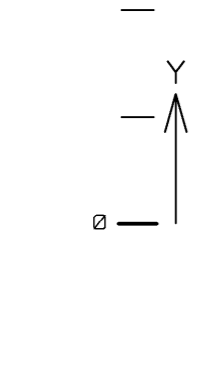

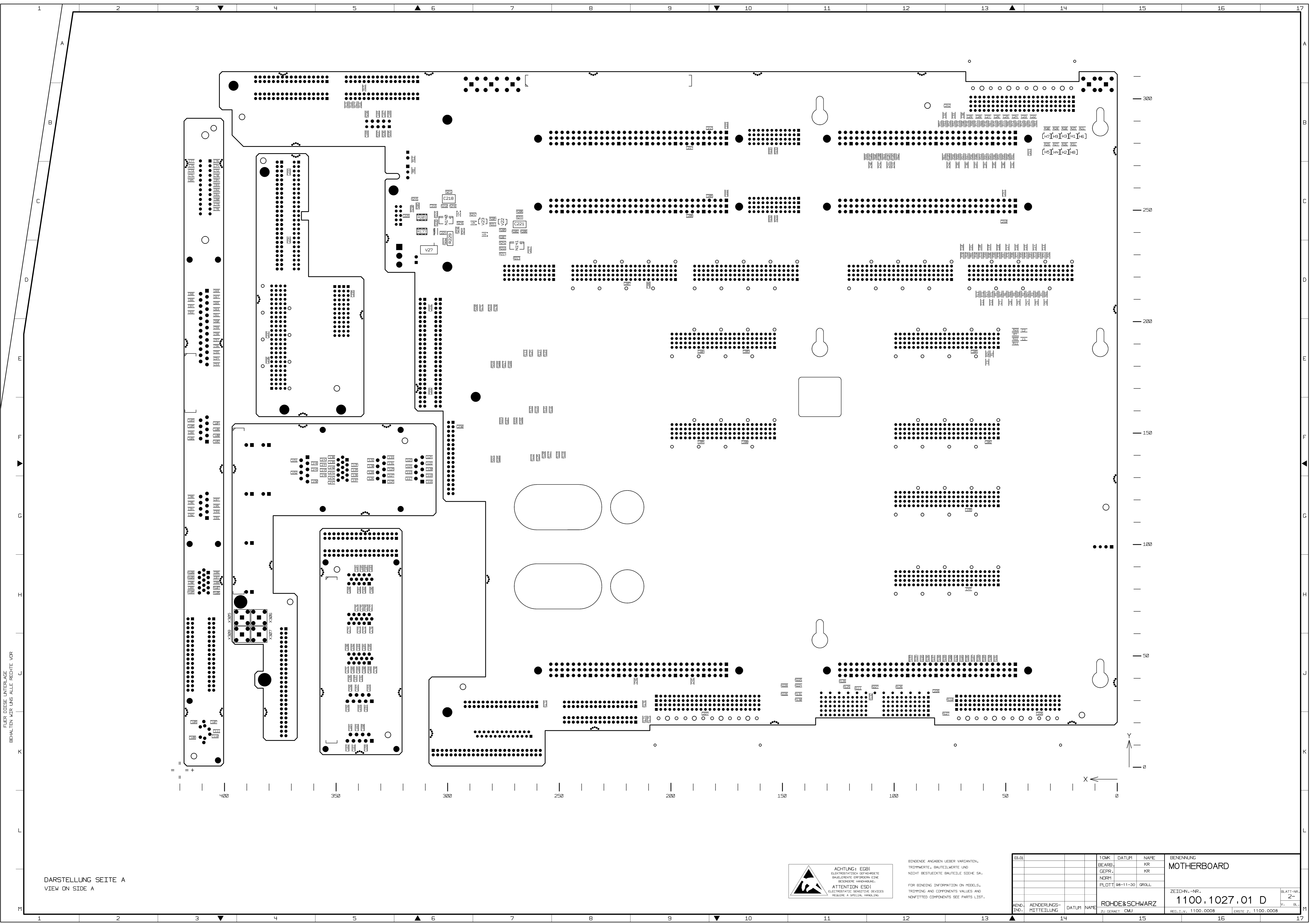

FÜR DIESE UNTERLAGE
BEHALTEN WIR UNS ALLE RECHTE VOR

DARSTELLUNG SEITE A
VIEW ON SIDE A

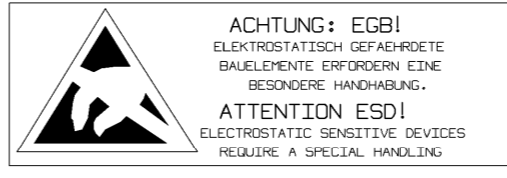

ACHTUNG: ESD!
ELEKTROSTATISCH GEFÄHRDETE
BAUTEILE ERFORDERN EINE
SPEZIELLE HANDHABUNG.
ATTENTION ESD!
ELECTROSTATIC SENSITIVE DEVICES
REQUIRE A SPECIAL HANDLING.

BINDENDE ANGABEN LEIDER VARIANTEN,
TRIMMWERTE, BAUTEILWERTE UND
NICHT BESTUICKTE BAUTEILE SIEHE SA.

FOR BINDING INFORMATION ON MODELS,
TRIMMING AND COMPONENTS VALUES AND
NONFITTED COMPONENTS SEE PARTS LIST.

09.01								TWK	DATUM	NAME	BENENNUNG			
								BEARB.	KR	KR	MOTHERBOARD			
								GEPR.						
								NDRM						
								PLOTT	08-11-30	GRÖLL				
											ZEICHN.-NR.	BLATT-NR.		
											1100.1027.01 D	2-		
											REG.-L.W.	V. BL.		
											1100.0008	1100.0008		
											ERSTE Z.	1100.0008		
								AEND.	DATUM	NAME				
								ZU GERÄT	CMU					

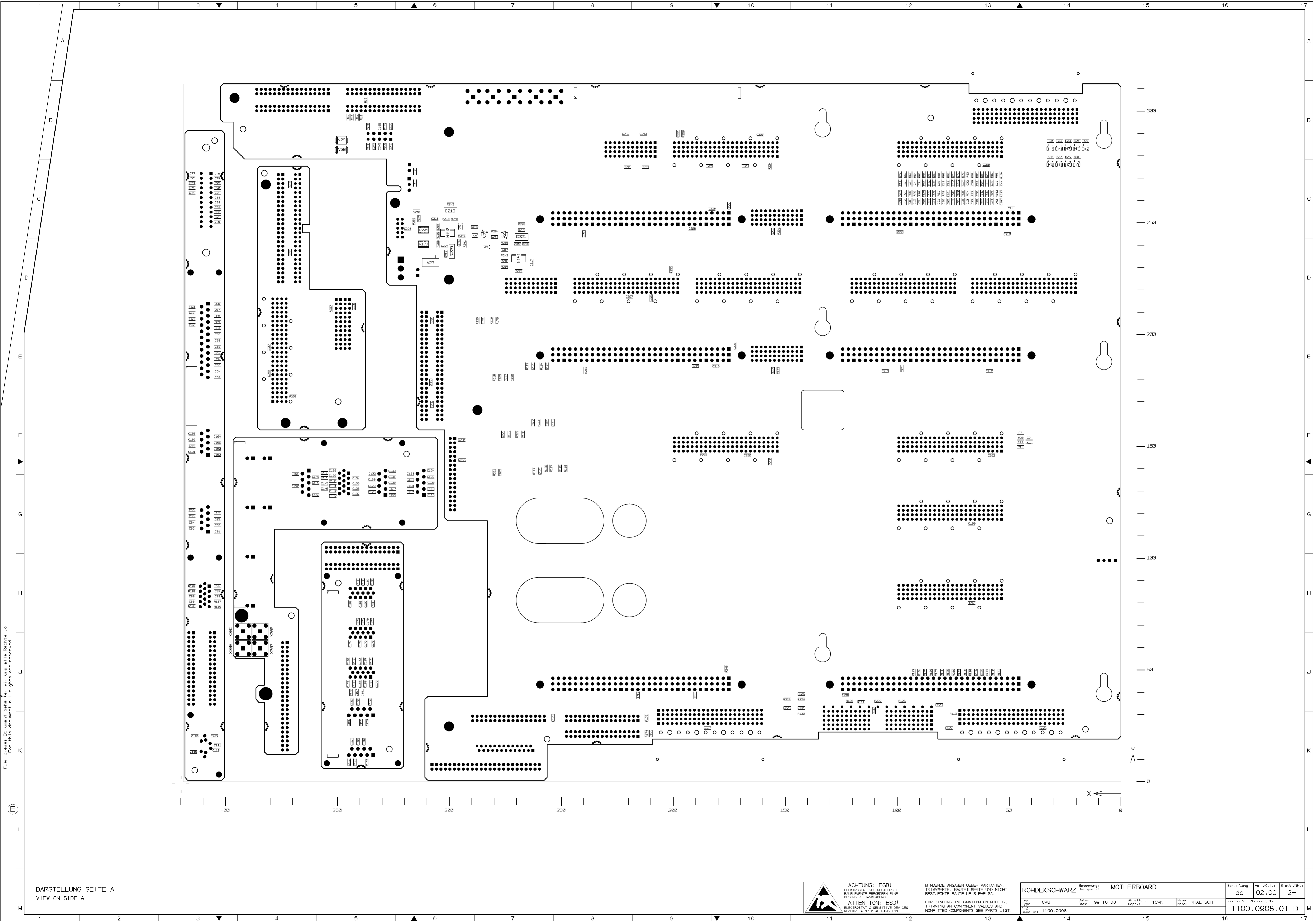

Four dieses Dokument behalten wir uns alle Rechte vor
 For this document all rights are reserved

DARSTELLUNG SEITE A
VIEW ON SIDE A



ACHTUNG: ESD!
 ELEKTROSTATISCH GEFÄHRDETE
 BAUELEMENTE BEFORDERN EINE
 BESONDERE HANDHABUNG.
ATTENTION: ESD!
 ELEKTROSTATIC SENSITIVE DEVICES
 REQUIRE A SPECIAL HANDLING.

BINDENDE ANGABEN LIEFER VARIANTEN,
 TRIMMWERTE, RAUTE WERTE UND NICHT
 BESTÜCKTE BAUTEILE SIEHE SA.
 FOR BINDING INFORMATION ON MODELS,
 TRIMMING AND COMPONENT VALUES AND
 NON-FITTED COMPONENTS SEE PARTS LIST.

ROHDE&SCHWARZ Typ: CMU Date: 99-10-08 Blatt: 1100.0008		Benennung: MOTHERBOARD Abteilung: 1CMK Name: KRAETSCH		Ser.-/Lang.- de 02.00 Blatt/Bl. 2-
--	--	---	--	---

Zeichen.Nr./Drawing No.: 1100.0908.01 D

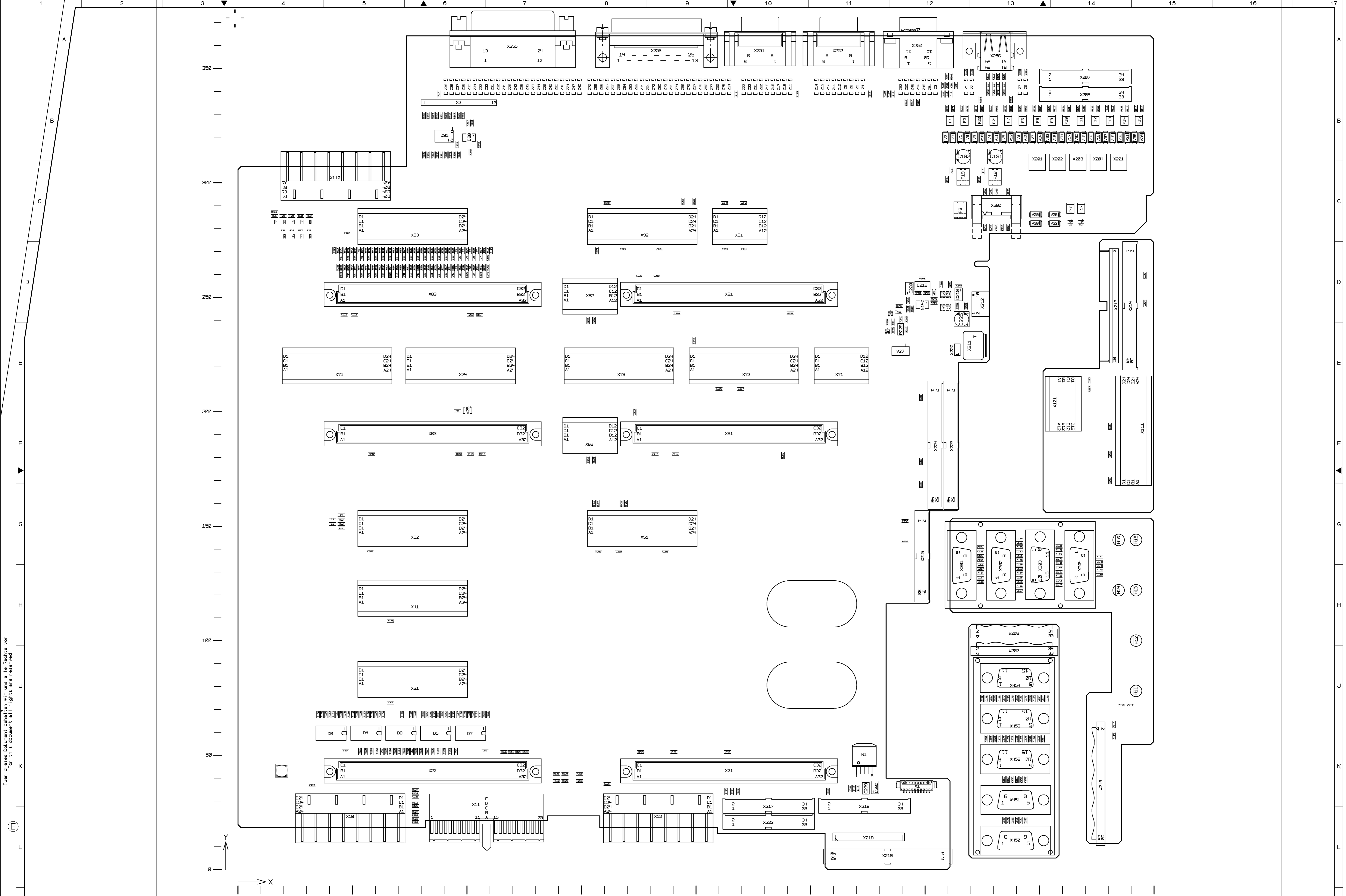

Für dieses Dokument behalten wir uns alle Rechte vor.
 For this document all rights are reserved.

DARSTELLUNG SEITE B
VIEW ON SIDE B



ACHTUNG: EGBI
 ELEKTROSTATISCH GEFÄHRDETE
 BAUELEMENTE ERFORDERN EINE
 BESONDERE HANDLUNG.
ATTENTION: ESDI
 ELECTROSTATIC SENSITIVE DEVICES
 REQUIRE A SPECIAL HANDLING.

BINDENDE ANGABEN LIEFERN VARIANTEN,
 TRIMMWERTE, BAUTEILWERTE UND NICHT
 BESTLEBTE BAUTEILE SIEHE SA.
 FOR BINDING INFORMATION ON MODELS,
 TRIMMING AND COMPONENT VALUES AND
 NON-FITTED COMPONENTS SEE PARTS LIST.

ROHDE&SCHWARZ Benennung: MOTHERBOARD CMU Designet.: MOTHERBOARD CMU		Sp.: Lang.: de Act/C.: 05.01 Blatt/Sh.: 1+
Typ: CMU Datum: 05-01-13 T.: 1.1 used in: 1100.0008	Abteilung: 1CMK Name: SEIFFELT	Zeichen: 1100.2352.01 D

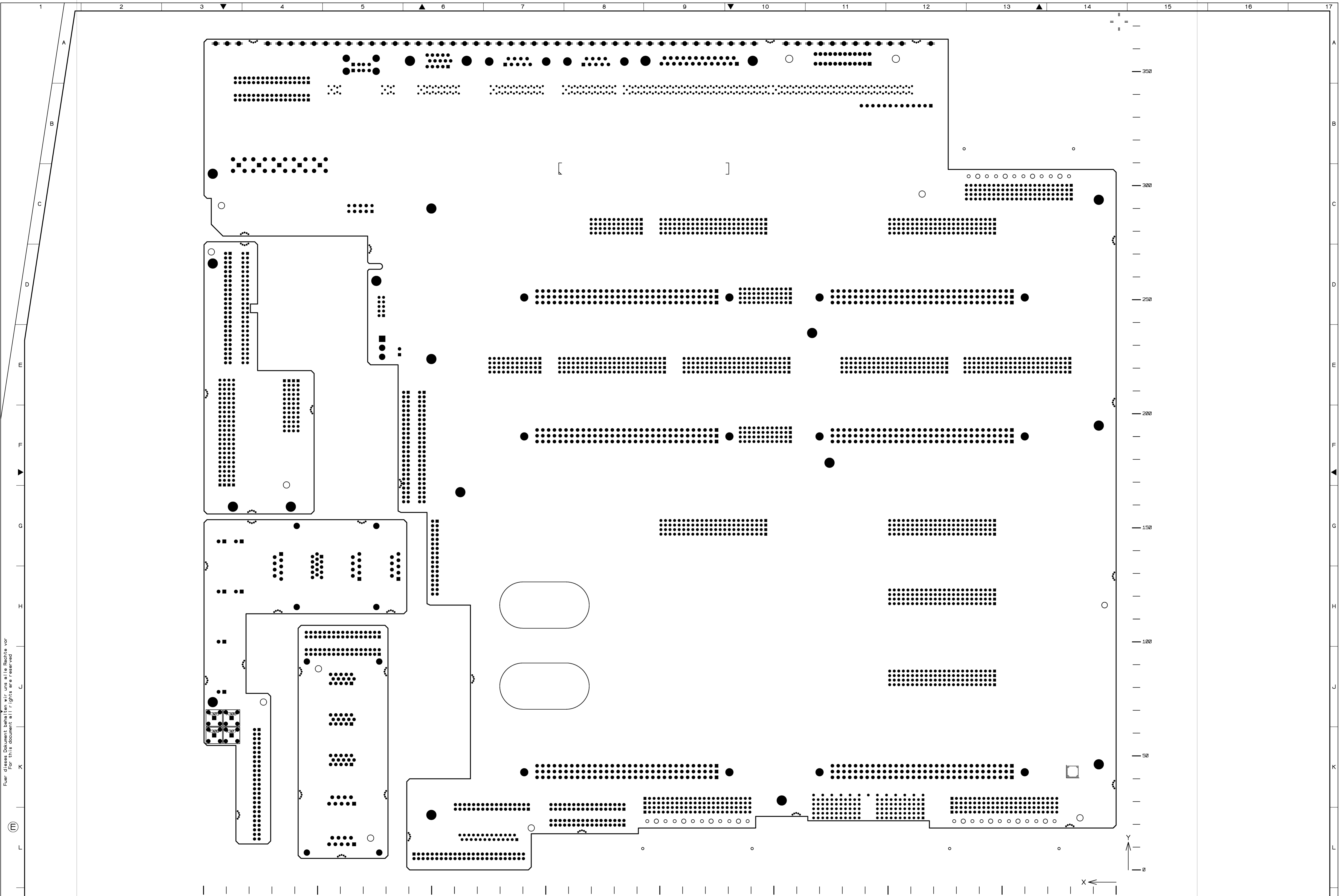

Für dieses Dokument behalten wir uns alle Rechte vor.
 For this document all rights are reserved.

DARSTELLUNG SEITE A
VIEW ON SIDE A

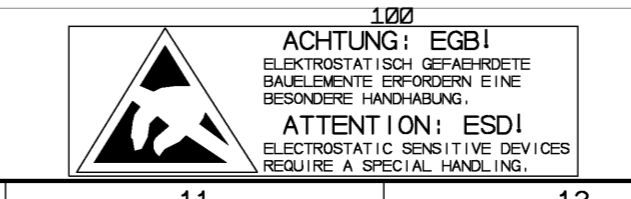

ACHTUNG: EGBI
 ELEKTROSTATISCH GEFÄHRDETE
 BAUELEMENTE ERFOORDERN EINE
 BESONDERE HANDHABUNG.
 ATTENTION: ESDI
 ELECTROSTATIC SENSITIVE DEVICES
 REQUIRE A SPECIAL HANDLING.

BINDENDE ANGABEN LIEFER VARIANTEN,
 TRIMMIERTE, BAUTEILWERTE UND NICHT
 BESTLECKTE BAUTEILE SIEHE SA.
 FOR BINDING INFORMATION ON MODELS,
 TRIMMING AND COMPONENT VALUES AND
 NON-FITTED COMPONENTS SEE PARTS LIST.

ROHDE&SCHWARZ Typ: CMU Date: 05-01-10 T.Z.: 1100.0008		Benennung: MOTHERBOARD CMU Designat.: MOTHERBOARD CMU Datum: 05-01-10 Abteilung: 1CMK Name: SEIFFELT		Sp.: 1/1 Anl./C.: 1 Blatt/zh.: 2-
Zeichn.-Nr.: 1100.2352.01 D			Drawing No.:	



Circuit Diagrams

for CMU Basic Unit

Fuer diese Unterlage behalten wir uns alle Rechte vor
 For this document all rights are reserved

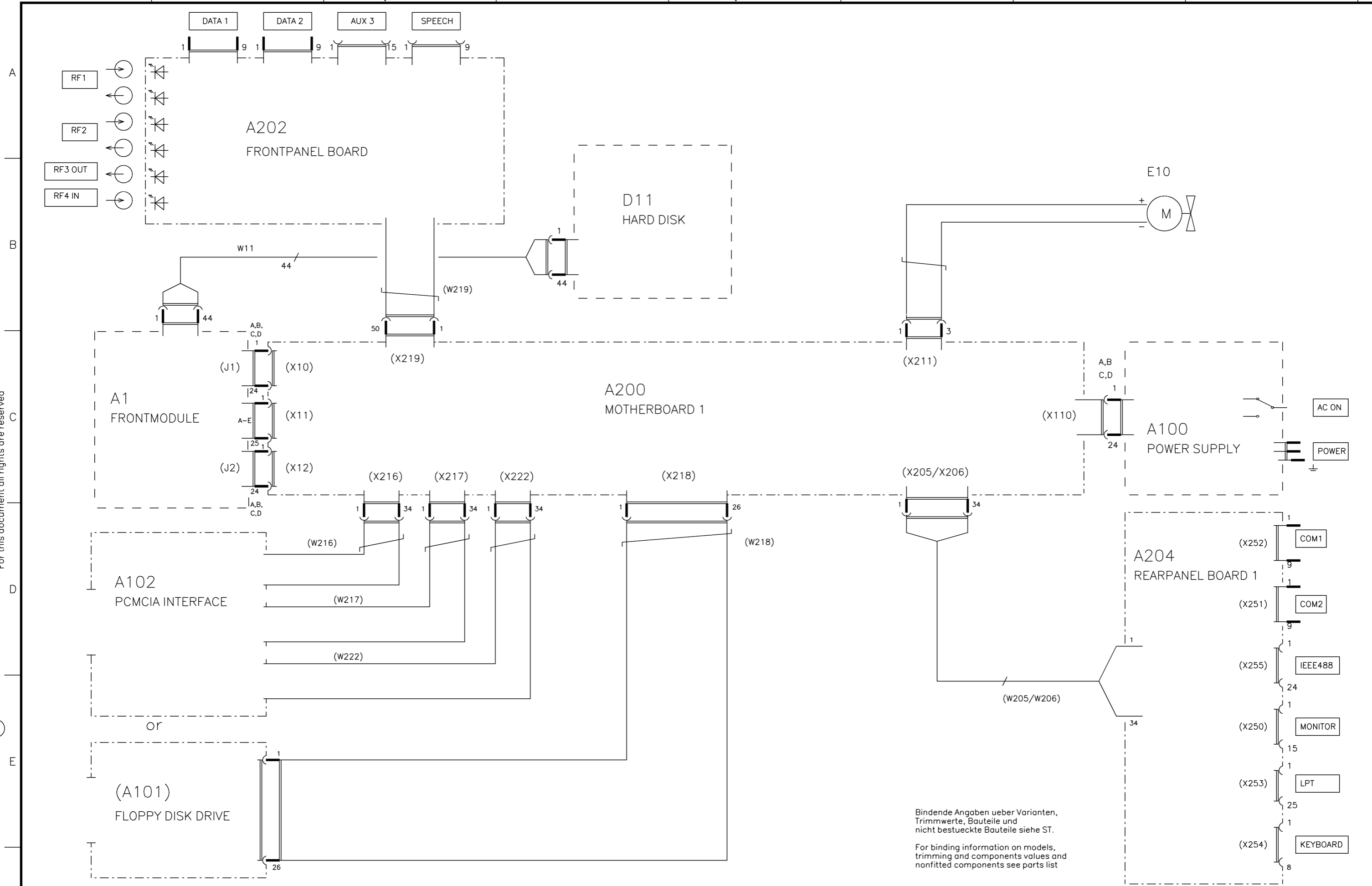

Bindende Angaben ueber Varianten,
 Trimmwerte, Bauteile und
 nicht bestueckte Bauteile siehe ST.
 For binding information on models,
 trimming and components values and
 nonfitted components see parts list

ROHDE&SCHWARZ Benennung: CMU200 UNIV.RADIOCOM. Designation: CMU200 UNIV.RADIOCOM.				Sprache: / Lang.: DE Aei: / C.I.: 08.00 Blatt: / Sh.: 1+	
Typ: CMU200 1. Z.: used in:		Datum: 03-09-09 Date: 03-09-09		Abteilung: 1CMK Dpt: 1CMK Name: BERNDT Name: BERNDT	
				Zeichn. Nr.: / Drawing No.: 1100.0008.01 S TOP/TOP.1	

Fuer diese Unterlage behalten wir uns alle Rechte vor
 For this document all rights are reserved

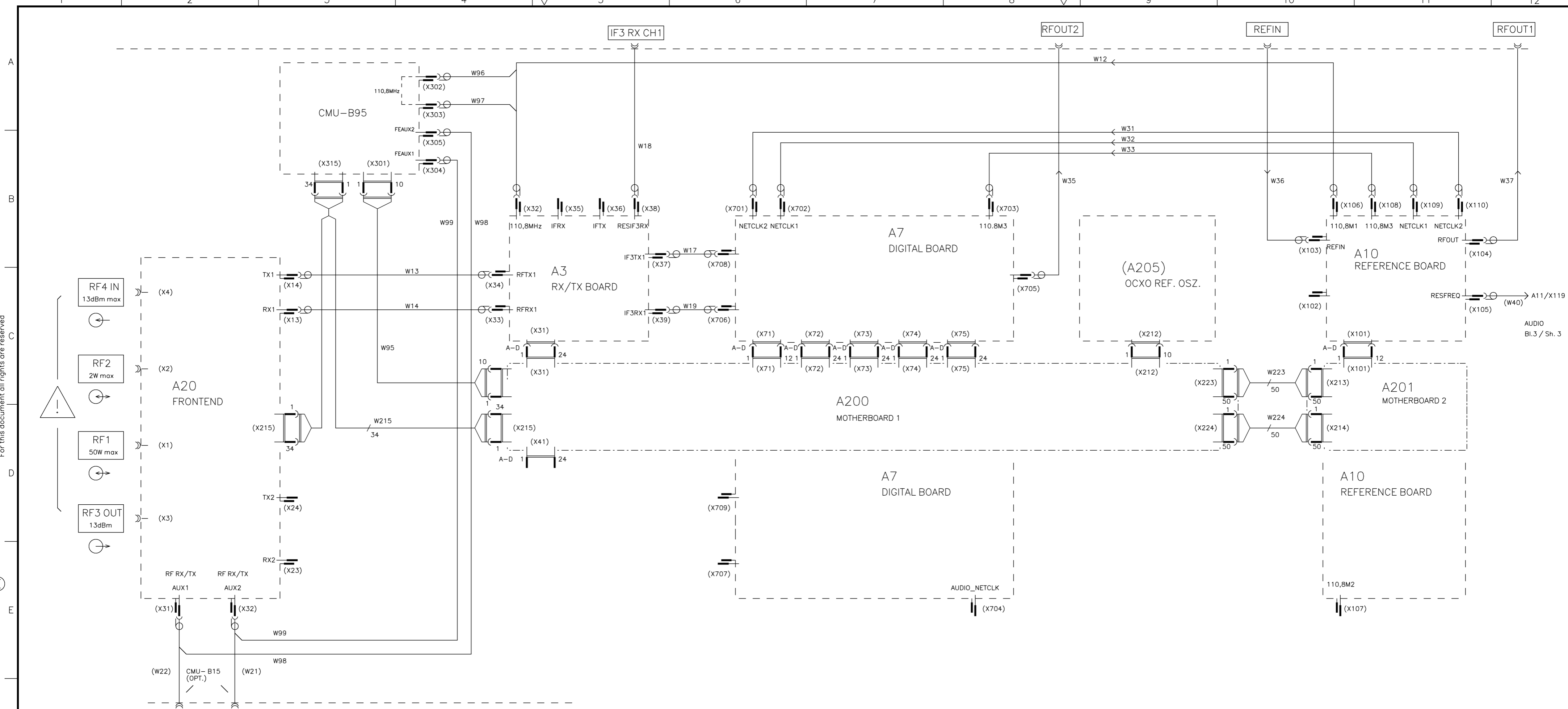

ROHDE&SCHWARZ				Benennung: CMU200 UNIV.RADIOCOM.		Sprache: / Lang.: DE		Aei: / C.I.: 08.00		Blatt: / Sh.: 2+	
Typ: CMU200		Datum: 03-09-09		Abteilung: 1CMK		Name: BERNDT		Zeichn. Nr.: / Drawing No.: 1100.0008.01 S			
1. Z.:		used in:		TOP/TOP.2							

Fuer diese Unterlage behalten wir uns alle Rechte vor
 For this document all rights are reserved

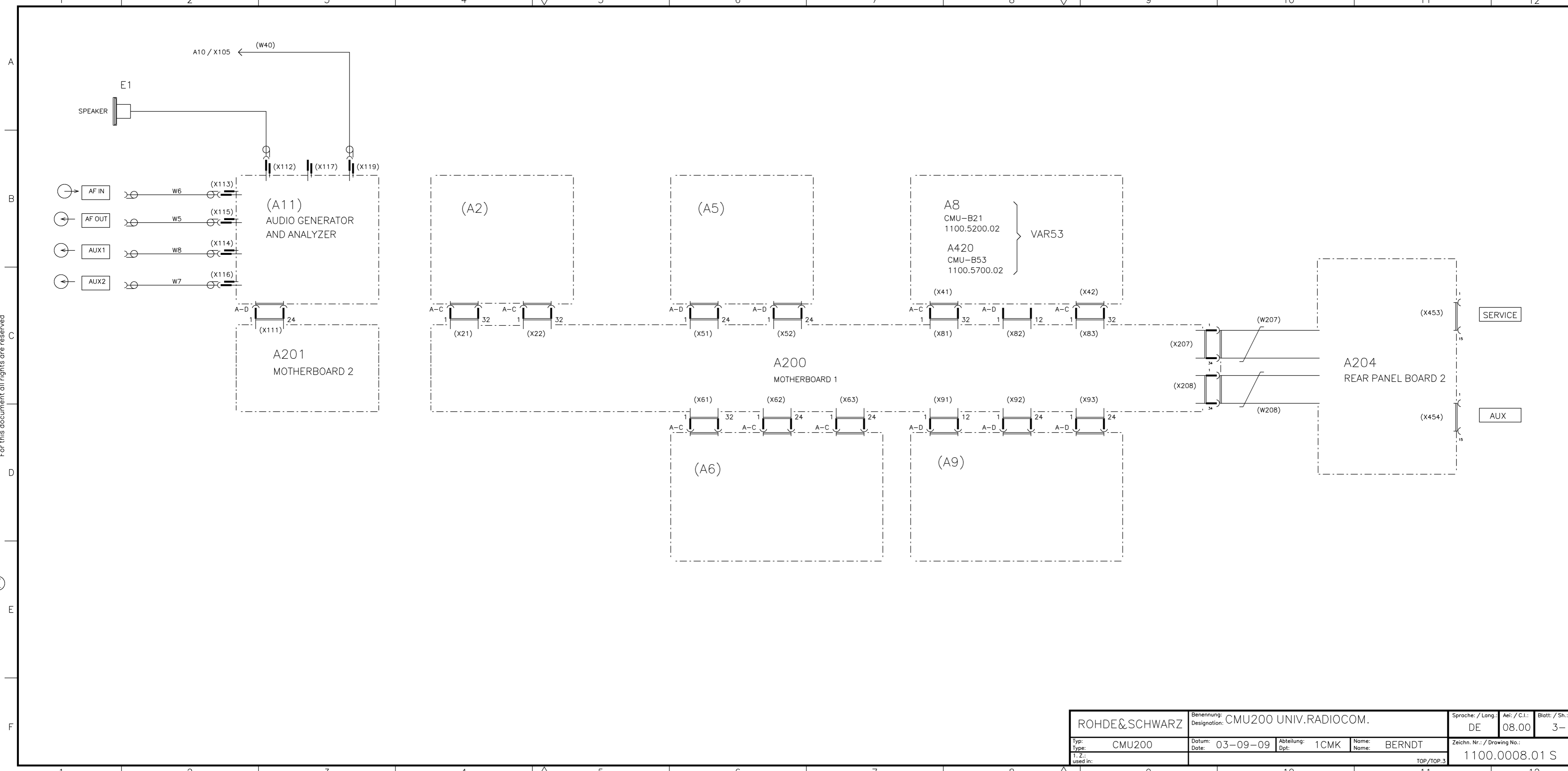

ROHDE&SCHWARZ				Benennung: CMU200 UNIV.RADIOCOM. Designation:			Sprache: / Lang.: DE		Aei: / C.I.: 08.00		Blatt: / Sh.: 3-	
Typ: CMU200		Datum: 03-09-09		Abteilung: 1CMK		Name: BERNDT		Zeichn. Nr.: / Drawing No.: 1100.0008.01 S				
1. Z.: used in:		TOP/TOP.3										